

# **WINPOWER**

*A Division of **DT** Dyna Technology Inc*

## **PARTS LIST**

# **WP85FPTOS/B**

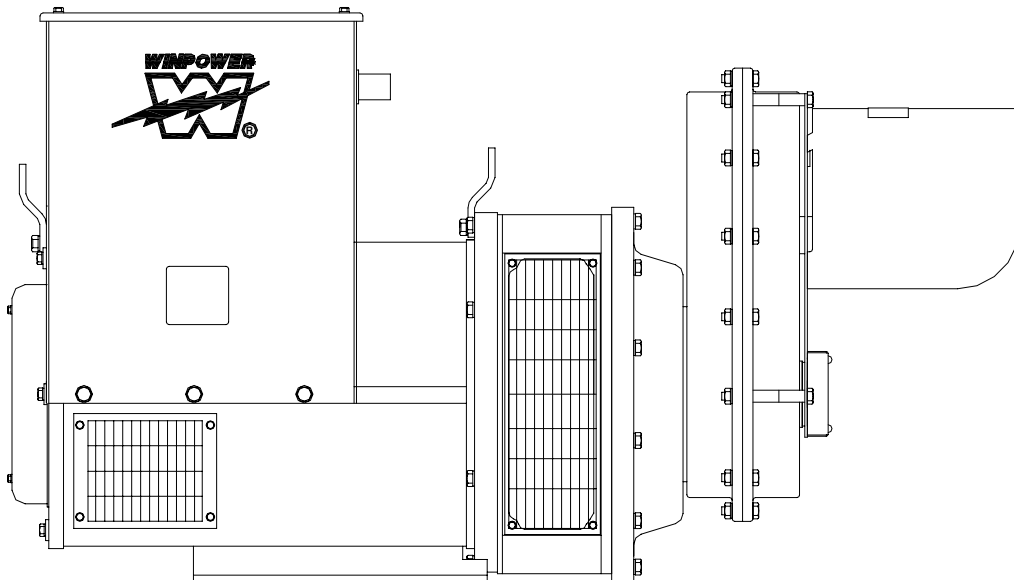

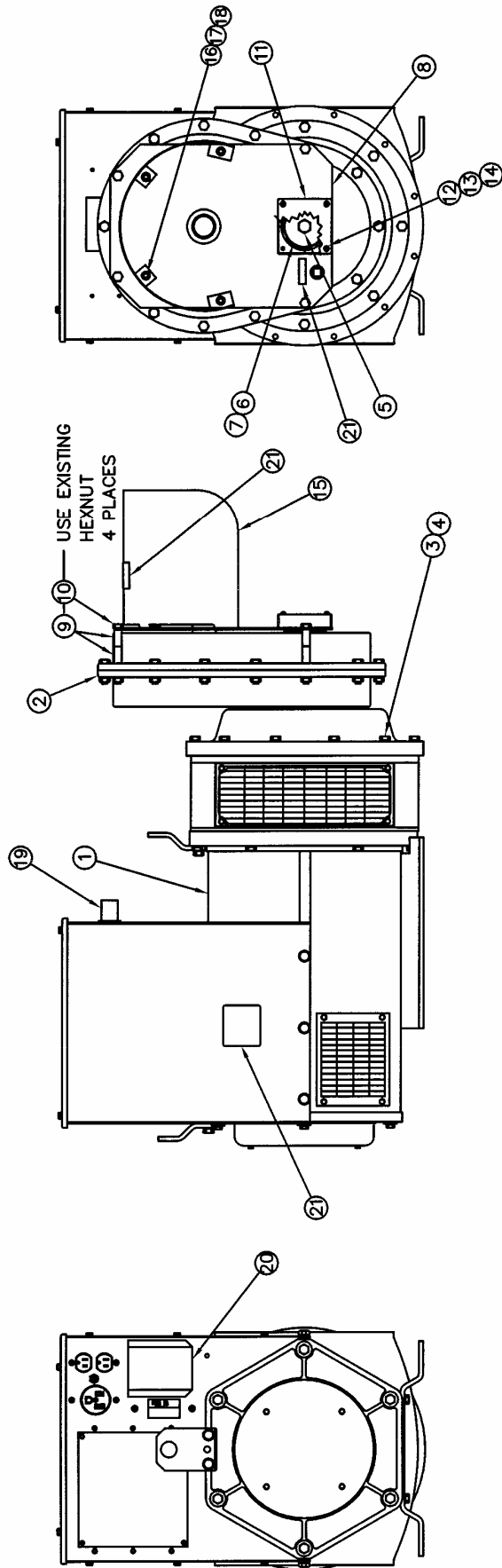

# GENERATOR ASSEMBLY

26	1744-000	4	1/2-13 HEXNUT (SHIPPING)
25	21867-000	4	1/2 FLATWASHER (SHIPPING)
24	A-61603-005	4	1/2-13 X 2-1/2 CARRIAGE BOLT (SHIPPING)
23	A-BP-10099	1	PLUG KIT (SHIPPED LOOSE)
22	60708-124	1	OPERATOR'S MANUAL
21	B-64894-000	1	DECAL AND NAMEPLATE INSTALLATION
20	B-300113-8	1	RECEPTACLE PANEL ASSEMBLY
19	B-300101-14	1	MAIN LINE BREAKER PANEL ASSEMBLY
18	A-16249-000	4	5/16-18 HEX FLANGENUT
17	526-000	4	5/16 FLAT WASHER
16	465-000	4	5/16-18 X 7/8 HEX HEAD BOLT
15	S-7606	1	PTO SHAFT GUARD
14	484-000	4	#10 SPLIT LOCKWASHER
13	456-000	4	#10-24 HEX NUT
12	A-52464-002	4	#10-32 X 1-1/2 ROUND HEAD SCREW
11	A-300105	1	LOWER SHAFT GUARD
10	A-91658-015	4	3/8-16 X 4 HEX HEAD BOLT
9	A-62825-004	8	SPACER
8	A-300104	1	PTO SHAFT GUARD SUPPORT PLATE
7	A-300096	1	SHAFT WASHER
6	A-300106-1	1	BELLEVILLE WASHER, 5/8"
5	A-350096-60	1	M16-2.00 X 60MM HEX HEAD BOLT
4	A-97436-008	12	M8 SPLIT LOCKWASHER
3	A-96002-040	12	M8 X 1.25 x 40MM HEX HEAD BOLT
2	B-300100-1	1	GEARCASE
1	B-351810-51	1	GENERATOR
ITEM	PART NO	QUAN.	DESCRIPTION

# CIRCUIT BREAKER PANEL ASSEMBLY

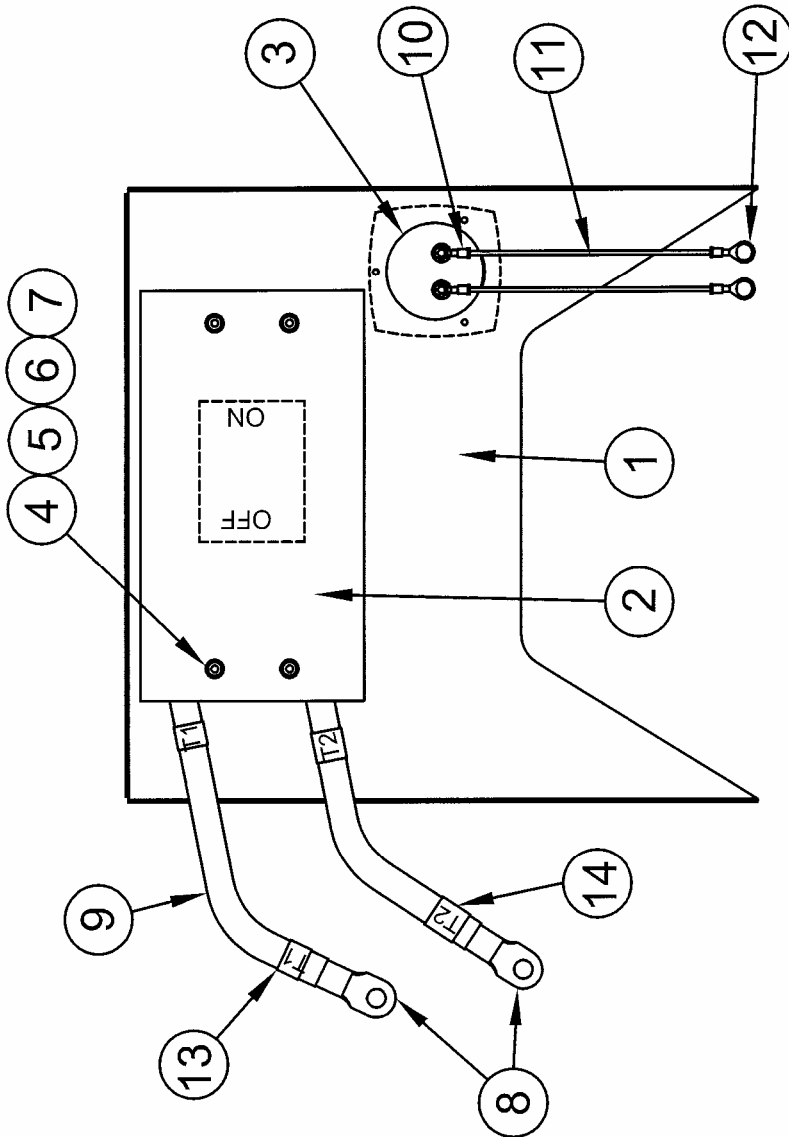

ITEM	PART NO	QUAN.	DESCRIPTION
14	B-24862-011	2	LEAD I.D. TAPE (T2)
13	B-24862-010	2	LEAD I.D. TAPE (T1)
12	A-91457-002	2	TERMINAL LUG
11	A-12624-000	1.7FT	LEAD WIRE (16 GA.)
10	A-4158-000	2	TERMINAL LUG
9	A-300114	2.92FT	LEAD WIRE (#3/0 AWG)
8	A-99823-001	2	TERMINAL LUG
7	598	4	#10 FLAT WASHER
6	484	4	#10 SPLIT TYPE LOCKWASHER
5	6372-000	4	#10-32 HEX NUT
4	24864-000	4	10-32 x 4-1/2 ROUND HEAD SCREW
3	A-300102	1	FREQUENCY METER
2	A-81094-9	1	CB, 350 AMP, 2 POLE
1	B-350028-1	1	PANEL, MLB

# RECEPTACLE PANEL ASSEMBLY

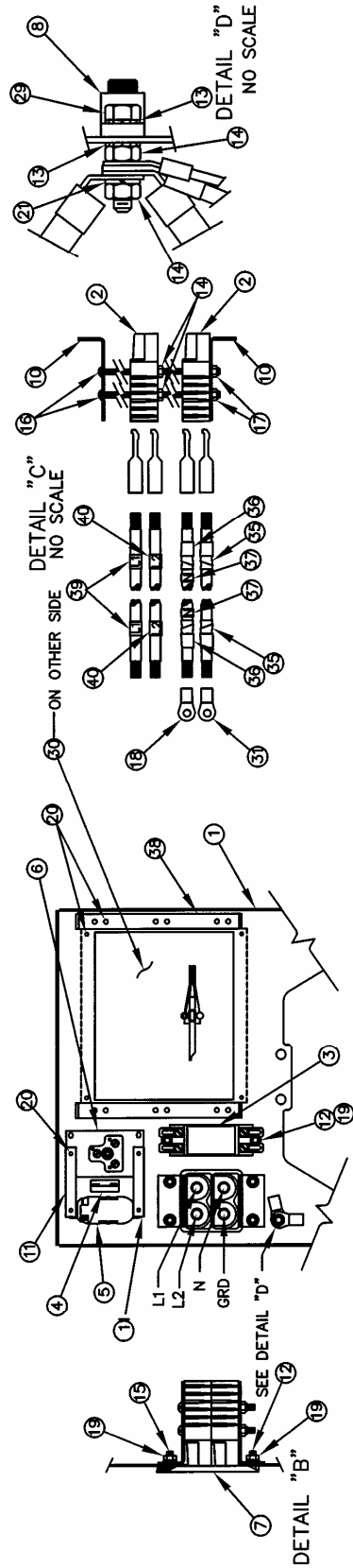

ITEM	PART NO	QUAN.	DESCRIPTION	ITEM	PART NO	QUAN.	DESCRIPTION
41	A-7547-000	1	TERMINAL LUG	40	B-24862-014	2	LEAD ID. TAPE - L2
39	B-24862-013	2	LEAD ID. TAPE - L1	38	A-64893-000	2	REGULATOR BRACKET
37	B-24862-078	2	LEAD ID. TAPE - N	36	A-80733-000	2.75FT	WHITE TAPE
35	A-59320-000	.92FT	GREEN TAPE	34	A-59341-000	1.33FT	#14 GREEN LEADWIRE
33	A-64638-000	1.25FT	#10 GA GREEN LEADWIRE	32	A-4155-000	1	TERMINAL LUG
31	A-91321-001	2	TERMINAL LUG	30	A-64892-000	1	COVER PLATE
29	439-000	1	HHCS, 1/4-20 x 1	28	A-80726-000	2.7 FT	#2 GA BLACK LEADWIRE
27	A-91780-000	3.92FT	#8 GA BLACK LEADWIRE	26	A-91815-000	3.30FT	#14 GA BLACK LEADWIRE
25	A-91321-000	2	TERMINAL LUG	24	B-48602-001	2	TERMINAL LUG
23	B-21850-002	3	TERMINAL LUG	22	A-4160-000	1	TERMINAL LUG
21	479-000	1	1/4 SPLIT LOCKWASHER	20	A-21698-001	14	#10 X 3/8 TYPE Z SHEET METAL SCREW
19	A-16248-000	6	1/4-20 FLANGE HEXNUT	18	A-99823-001	2	TERMINAL LUG
17	47517-000	2	LOCKNUT	16	A-61993-001	2	1/4-20 X 3-1/2 ROUND HEAD SCREW
15	A-94980-001	2	1/4-20 X 5/8 THREADSTUD	14	638-000	4	1/4-20 HEXNUT
13	4516-000	2	1/4" EXTERNAL LOCKWASHER	12	463-000	4	1/4-20 x 1 HEX HEAD BOLT
11	B-64045-002	2	STRIP, MOUNTING	10	A-300117	2	SUPPORT, CONNECTOR
9	A-300114	5.4 FT	3/0 AWG BLACK LEADWIRE	8	A-63708-000	1	TERMINAL LUG
7	(A)G-7213-1	1	COVER ASSEMBLY	6	A-57325-000	1	50 AMP, 250 VOLT RECEPTACLE
5	A-50766-000	1	20 A, 125 VOLT DUPLEX RECEPTACLE	4	A-91286-001	1	20 AMP, 1 POLE CIRCUIT BREAKER
3	A-57030-000	1	50 AMP, 2 POLE CIRCUIT BREAKER	2	EE-2334-1	2	HOUSING & CONTACTS
1	B-300112-1	1	PANEL FRONT				
ITEM	PART NO	QUAN.	DESCRIPTION	ITEM	PART NO	QUAN.	DESCRIPTION

# DECAL INSTALLATION

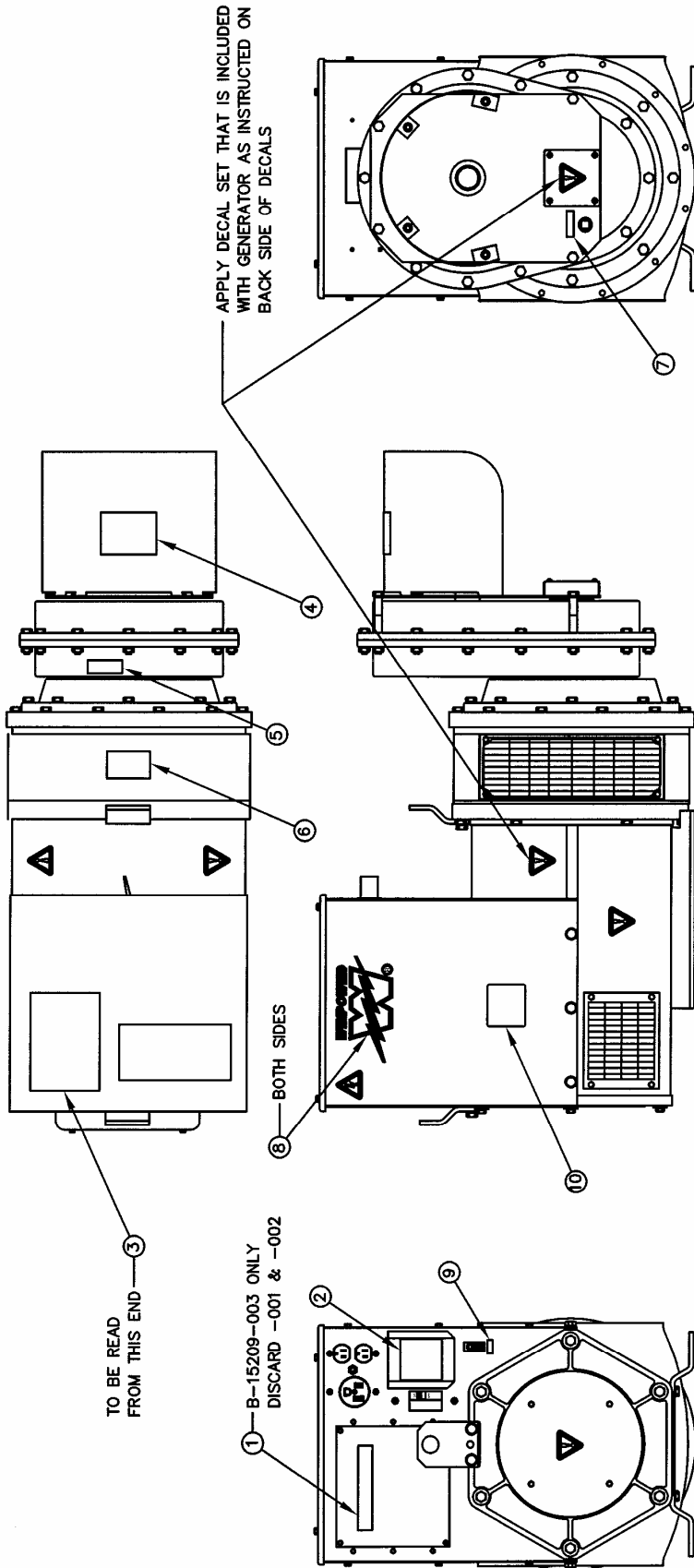

10	A-63966-008	1	NAMEPLATE KIT
9	A-15750-001	1	GROUND DECAL
8	Z-25081	2	WINPOWER DECAL
7	A-16303-000	1	DECAL, OIL LEVEL
6	A-91369-001	1	DECAL, 1000 RPM
5	Z-9941	1	DECAL, OIL FILL
4	Z-2568	1	DECAL-DANGER PTO
3	Z-2553	1	DECAL, OPERATING INSTRUCTIONS
2	Z-2527-2	1	DECAL, ANDERSON SINGLE PHASE
1	B-15209-000	1	DECAL SET
ITEM	PART NO	QUAN.	DESCRIPTION

# WIRING DIAGRAM

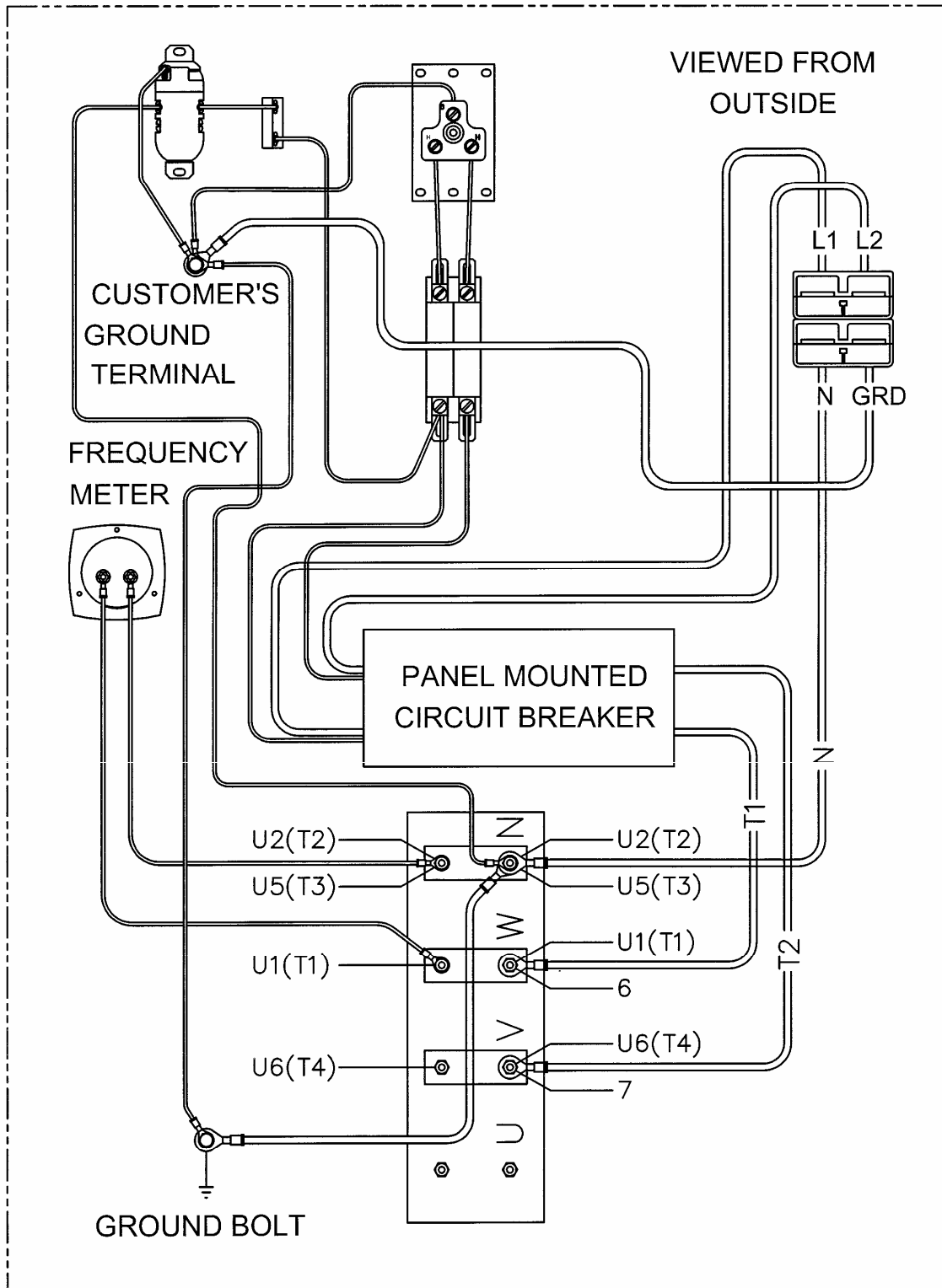

WIRING DIAGRAM (SINGLE PHASE "4 WIRE"; 120/240)