

OWNERS MANUAL

INSTALLATION AND OPERATION INSTRUCTIONS

**WP40PTOT
WP45PTOT
WP50PTOS
WP75FPTOT**



SAFETY FIRST

READ THIS MANUAL BEFORE OPERATING YOUR GENERATOR.

Read and understand all instructions in this manual before starting and operating the generator set.

USING THIS MANUAL

Congratulations on your choice of a Winpower generator set. You have selected a high-quality, precision-engineered generator set designed and tested to give you years of satisfactory standby service.

To get the best performance from your new generator set, it is important that you carefully read and follow the operating instructions in this manual.

Should you experience a problem please follow the "Things To Check" near the end of this manual. The warranty listed in this manual describes what you can expect from WINPOWER should you need service assistance in the future.

TABLE OF CONTENTS

INTRODUCTION	i
GUIDE TO PRODUCT SAFETY	1
BASIC INFORMATION	
Unit Capabilities	2
PREPARING THE UNIT	2
Unpacking the unit	2
Assembly	2
INSTALLATION	
Foundation Mounting	3
Trailer Mounting	3
ELECTRICAL CONNECTIONS	4
OPERATION	5
Pre-Start Checks	5
Starting Procedure	6
Stopping	6
MAINTENANCE	7
Lubrication	7
Cleaning	8
Storage	8
Trouble Shooting Table	8
36 MONTH WARRANTY	10

PROPER USE AND INSTALLATION

You must be sure your new generator set is:

- * Properly serviced before operating
- * Operated in a well ventilated area
- * Exhaust gases are dispersed safely
- * Wired by a qualified electrician
- * Operated only for its designed purposes
- * Used only by operators who understand its operation
- * Properly maintained

COPY YOUR MODEL AND SERIAL NUMBER HERE

No other WINPOWER generator has the same serial number as yours. It is important that you record the number and other vital information here, if you should ever need to contact us on this unit it will help us to respond to your needs faster.

MODEL _____

SERIAL NUMBER _____

PURCHASE DATE _____

DEALER _____

SAFETY INFORMATION

This generator set has been designed and manufactured to allow safe, reliable performance. Poor maintenance, improper or careless use can result in potential deadly hazards; from electrical shock, exhaust gas asphyxiation, or fire. Please read all safety instructions carefully before installation or use. Keep these instructions handy for future reference. Take special note and follow all warnings on the unit labels and in the manuals.

ANSI SAFETY DEFINITIONS

DANGER:

DANGER indicates an imminently hazardous situation which, if not avoided, will result in death or serious injury. This signal word is to be limited to the most extreme situations.

WARNING:

WARNING indicates a potentially hazardous situation which, if not avoided, could result in death or serious injury.

CAUTION:

CAUTION indicates a potentially hazardous situation which, if not avoided, may result in minor or moderate injury. It may also be used to alert against unsafe practices.

NOTE:

CAUTION is also used on the unit labels and in this manual to indicate a situation that could result in serious damage or destruction of the equipment and possible personal injury.

1. **ELECTRIC SHOCK-** The output voltage present in this equipment can cause a fatal electric shock. This equipment must be operated by a responsible person.

- a. Do not allow anyone to operate the generator without proper instruction.
- b. Guard against electric shock.
- c. Avoid contact with live terminals or receptacles.
- d. Use extreme care if operating this unit in rain or snow.
- e. Use only three-prong grounded plugs and extension cords.
- f. Be sure the unit is properly grounded to an external ground rod driven into the earth.
- g. Do not make or break electrical connection under load.

2. **FIRE HAZARD-** Gasoline, diesel and other fuels always present a hazard of possible explosion and/or fire.

- a. Keep a fire extinguisher nearby and know its proper use. Fire extinguishers rated ABC by NFPA are appropriate.

3. **DEADLY EXHAUST GAS** - Exhaust fumes from any engine contain carbon monoxide, an invisible, odorless and deadly gas that must be mixed with fresh air.

- a. Operate only in well ventilated areas.
- b. Never operate indoors.

4. **NOISE HAZARD** - Excessive noise is not only tiring, but continual exposure can lead to loss of hearing.

- a. Use hearing protection equipment when working around this equipment for long periods of time.
- b. Keep your neighbors in mind when permanently installing this equipment.

5. **CLEANLINESS-** Keep the generator and surrounding area clean.

- a. Remove all grease, ice, snow or materials that create slippery conditions around the unit.
- b. Remove any rags or other material that could create potential fire hazards.

6. **SERVICING EQUIPMENT-** All service, including the installation or replacement of service parts, should be performed only by a qualified technician.

- a. Use only factory approved repair parts.
- b. Do not work on this equipment when fatigued.
- c. Use extreme caution when working on electrical components. High output voltages from this equipment can cause serious injury or death.
- d. Always avoid hot mufflers, exhaust manifolds, and engine parts. They all can cause severe burns instantly.

7. **INSTALLATION-** Installing a PTO generator is not a “do-it-yourself” project. Consult a qualified, licensed electrician or contractor. The installation must comply with all national, state, and local codes.

- a. Never operate the PTO drive generator without having it properly mounted to a concrete base or approved trailer.
- b. Never connect the PTO generator to an existing electrical system without installing an isolation transfer switch.
- c. Always insure the drive shaft is straight and level before operating the generator.

8. **OPERATION** - PTO drive shafts (Tumbling Bars) have many inherent dangers, extreme caution must be exercised when using them.

- a. **NEVER** allow children around a drive shaft when it is in operation.
- b. Keep all safety guards and shields in place and securely tightened.
- c. Never operate a drive shaft that has been damaged or had the safety shield removed.
- d. Never step over a drive shaft while it is running.
- e. Never wear a necktie, loose articles of clothing, or anything else that can be caught in moving parts.
- f. Never try to stop a turndrive shaft with your hand or your foot.

Description

The WINPOWER PTO drive generator will provide, depending on the unit purchased, 120/240V single phase, 120/240V three phase or 120/208 three phase 60Hz electrical service when direct-driven. Tractor or vehicle power take-off shafts, can be used for driving these generators.

NOTE: The prime mover which drives the generator must be capable of delivering approximately 2 HP per 1000 watts output from the generator. Observe input RPM specifications.

The generator may be foundation mounted for use as standby power source, or trailer mounted, and used as portable electrical power sources for areas where commercial power is not readily available, such as out buildings.

This generator includes a load sensing transformer which provides extra motor starting power, a color coded voltmeter to warn against high or low voltage, three output power receptacles, an overload protection circuit, and an electronic excitation circuit. To reduce maintenance problems, the coupling between the generator input shaft and rotor consists of precision helical gearing rather than a chain link drive. The input shaft is splined, and is 1-3/8 in diameter.

The factory thoroughly tests each of these generators before shipment. All are continuous duty rated.

IMPORTANT: THE MANUFACTURER STRONGLY RECOMMENDS RUNNING THE GENERATOR UNDER LOAD AT LEAST ONCE A MONTH IN ORDER TO EVAPORATE ANY ACCUMULATED MOISTURE CONDENSATION

UNPACKING

CAUTION: Equipment Damage

DO NOT invert generator during unpacking. The Gearcase contains oil which will leak out if inverted during unpacking.

Unpack the generator as follows:

1. Remove the carton.
2. Examine the unit for damage.
3. Find the small subpack carton packed in the large carton. Be careful not to throw away the subpack carton with the large carton.
4. Open the subpack carton and make sure it contains:
 - a. Generator instruction manual
 - b. Load disconnect plug (disassembled, in bag)
5. Remove the four bolts which hold down the generator feet to the pallet.
6. Lift the generator from the pallet by means of the lifting eye on the top of the generator.
7. Inspect the generator carefully for freight loss or damage. If loss or damage is noted at time of delivery, require that the

person making the delivery make note of the loss or damage on the freight bill, or sign the consigner's memo of the loss or damage. Contact the carrier for claim procedures.

When loss or damage is noted after delivery, segregate the damaged material, and contact the carrier for claim procedures.

"Concealed damage" means damage to the contents of a package which is not evident when the package is delivered by the carrier, but which is discovered later. The carrier or carriers are responsible for merchandise lost or damaged in transit. The title to the goods rests with the consignee when the goods are shipped FOB factory, and only the consignee can legally file claims. Two years are allowed in which to file suit after a claim is disallowed in writing by the carrier.

Assembly

The only assembly work required after unpacking the generator is to assemble and wire the load disconnect plug, which is contained in a bag in the subpack carton packed in the generator crate. The bag contains an instruction sheet, a plug body, three or four brass pins (large pin for neutral line), and a small envelope. The small envelope contains an allen wrench, retainer pins, and set screws.

To wire the load disconnect plug, use the following type of cable:

Generator Model	Size, AWG	Insulation
WP40PTOT-D	4	600V, Neoprene
WP45PTOT-J	4	600V, Neoprene
WP50PTOS	1	600V, THW
WP75PTOT-D	1	600V, THW
WP75PTOT-J	1	600V, THW

To assemble and wire the load disconnect plug, proceed as follows (see Figure 1):

1. Cut cables to the required length.
2. Strip off insulation 7/8" back from one end of each cut-to-length cables.
3. Start threading a set screw into each pin.
4. Insert the stripped end of one cable fully into one of the brass pins, and tighten the set screw firmly to secure the cable end in the pin.

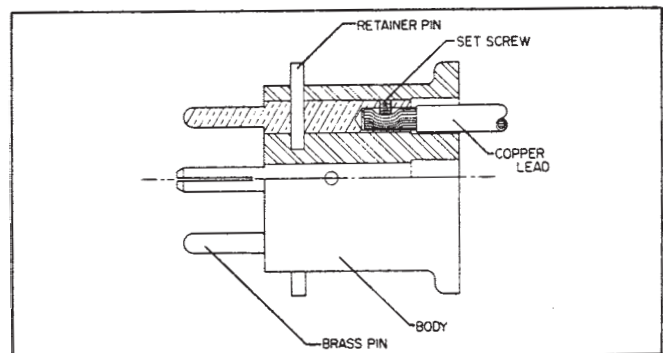

Figure 1

Octopus Plug Assembly

DANGER: Equipment Damage

If cable-to-pin connections are loose, arcing and heat damage to equipment can result.

5. Insert the brass pin (with cable) into the plug body, and line up the retainer pin holes in the brass pin with those in the plug body.
6. Insert the retainer pin, and tap it firmly into place. The retainer pin will protrude approximately 3/8" when fully seated. (See Figure 1.)
7. Repeat steps 4 through 6 for each brass pin. Make sure to connect the neutral lead (cable), identified and color coded in conformance with the applicable local electrical codes, to the large diameter pin ("N") on the plug.

WARNING: Electrical Shock

DURING THE NEXT STEP, THE LOAD DISCONNECT PLUG SHOULD NOT BE PLUGGED INTO ITS RECEPTACLE. ALSO, MAKE SURE THAT THE EQUIPMENT TO WHICH THE PLUG LEADS (CABLES) ARE BEING CONNECTED IS NOT ENERGIZED (LIVE).

8. Strip the insulation off the free end of each of the plug leads (cables), and connect them to the load transfer switch (or directly to the load).

Installation

FOUNDATION MOUNTING

Mount the generator on a foundation if it is to be used as a permanent or standby power source (see Figure 2). See "TRAILER MOUNTING" if generator will be used as a portable power source (see Figure 3). When planning a foundation consider the following points:

- A. The foundation location should enable aligning the drive shaft (tumbling bar) in a straight or nearly straight line between the power take-off and the generator input shaft. Misalignment must be less than 15 degrees during generator operation, even though the mechanical design of the tumbling bar would allow greater misalignment.
- B. The foundation must be solid enough to absorb generator starting and reflected load torque during operation.
- C. The foundation surface should be flat.
- D. Space is required around the generator for mounting switching devices, making connections, and for servicing.

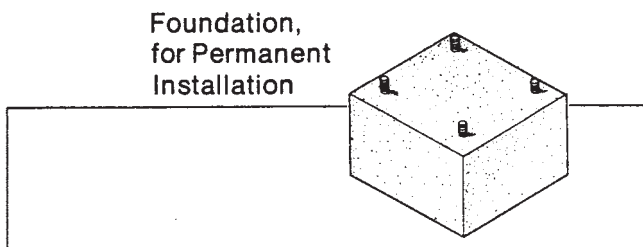

Figure 2

- E. All four generator mounting pads must rest firmly on the foundation. Install shims if necessary to even out the foundation under the mounting pads then bolt the generator firmly in place.

TRAILER MOUNTING

Mount the generator on a trailer if you plan to use it as a portable power source. See Figure 4. When selecting or building a trailer to mount the generator, consider the following points:

- A. The trailer construction must be strong enough to support the generator.
- B. The design of the trailer must enable the trailer to remain stable during operation, and to resist tipping caused by generator starting and reflected load torque.

WARNING: Personal Injury & Equipment Damage

TRAILER MAY TIP OVER AND CAUSE INJURIES IF WHEELS ARE NOT SPACED FAR ENOUGH APART.

- C. The trailer height and mounting position of the generator on the trailer should enable aligning the drive shaft (tumbling bar) in a straight or nearly straight line between the power take-off and generator input shafts. Misalignment must be less than 15 degrees during generator operation, even though the mechanical design of the tumbling bar would allow greater misalignment.
- D. The generator mounting area of the trailer bed should be flat. All four generator mounting pads must rest firmly on the trailer bed. Install shims if necessary to even out the bed under the mounting pads, then bolt the generator firmly in place.

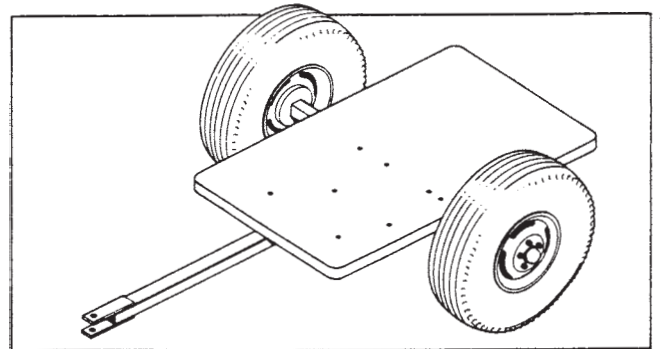

Trailer, for Portable Operation

Figure 3

ELECTRICAL CONNECTIONS

CAUTION:

Only qualified electricians should install electrical wiring. Wiring must conform to all applicable national, state, and local codes. (Reference: National Fire Protection Association Manual No. 70, National Electrical Code.)

DANGER: PERSONAL INJURY

IF THE GENERATOR IS TO BE USED AS A STANDBY

POWER SOURCE, A SPECIAL DISCONNECT SWITCH MUST BE INSTALLED TO SEPARATE THE GENERATOR AND THE COMMERCIAL POWER LINES. THE DISCONNECT MUST ISOLATE THE GENERATOR FROM THE COMMERCIAL POWER LINES AND THE LOAD WHEN THE GENERATOR IS ON STANDBY, AND MUST ISOLATE THE COMMERCIAL POWER LINES FROM THE LOAD AND THE GENERATOR WHEN THE GENERATOR IS SUPPLYING POWER. SEE FIGURE 5.

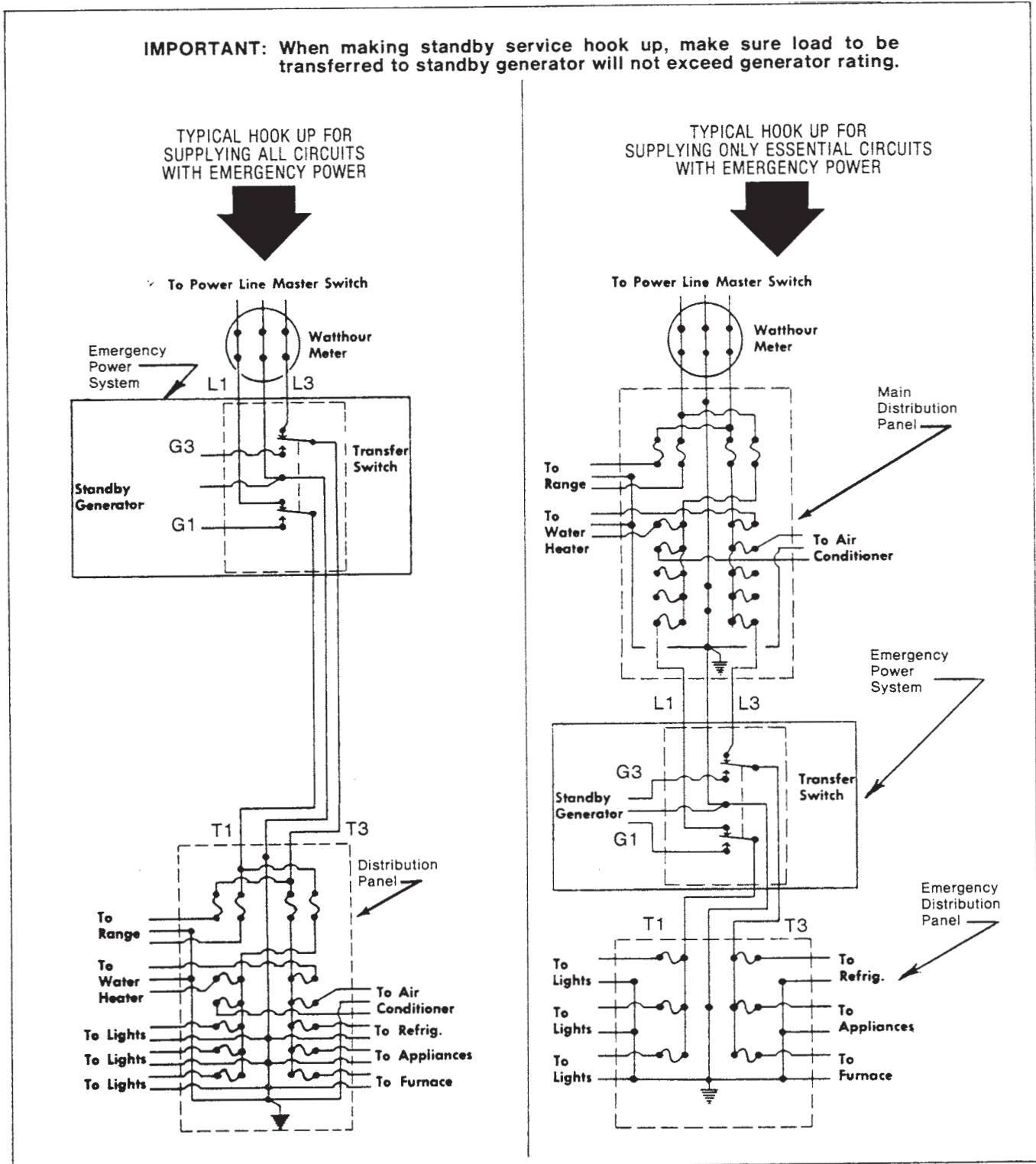

Figure 5

Typical Connection Methods for Generator Power Service

Operation

OUTPUT POWER AVAILABLE AND LOAD DETERMINATION

Before using the generator, read and understand the following information.

Generator output current (amperage) is internally limited by three circuit breakers. If too much demand is placed on a generator output (if you try to drive too many motors with it, for example), one of the circuit breakers will trip, cutting off the output in order to protect the generator.

A 15 amp push-to-reset circuit breaker protects the 120V duplex receptacle output circuit. 15 amps is the total limit for both outputs of the duplex receptacle.

A 50 amp two pole switch type circuit breaker protects the 240V receptacle output circuit.

A large two pole (three pole for three phase) switch type main circuit breaker protects the generator windings and output circuits, including the load disconnect receptacle outputs. (The load disconnect receptacle is the large round black rubber receptacle on the generator output panel.)

To aid in determining how much load can be applied to the generator, and how it should be distributed among the generator output receptacles, the following formulas may be useful. Get load voltage, current, and wattage from the nameplates on the equipment in the load.

$$\begin{aligned} (\text{Load Current, in amps}) \times (\text{Load Voltage}) &= (\text{Load Wattage}) \\ \text{AMPS} \times \text{VOLTS} &= \text{WATTS} \\ \text{WATT}/1000 &= \text{kW} \end{aligned}$$

$$(\text{Load Current in amps}) = (\text{Load Wattage})/(\text{Load Voltage})$$

Example:

$$250\text{W}, 120\text{V floodlight load} = 250\text{W}/120\text{V} = 2 \text{ amps (approx.)}$$

NOTE:

Electric motors require much more current to start than to run. Commonly, the current rating given on a motor nameplate is the full load (running) current required by the motor, not its starting current, which is a lot higher. Motor starting current requirements vary greatly, by motor size and type. Repulsion-induction type motors are the easiest to start, typically using 1 1/2 to 2 1/2 times as much current to start as to run; capacitor type motors usually require 2 to 4 times as much current to start as to run; split-phase type motors are the hardest to start, normally using 5 to 7 times as much current to start as to run.

MOTOR LOAD Motor Horsepower	SINGLE PHASE		THREE PHASE	
	115V Amps	230V Amps	208 Amps	240 Amps
	(Running Amps)		(Running Amps)	
1/4	5.8	2.9		
1/3	7.2	3.6		
1/2	9.8	4.9	2.3	2.0
3/4	13.8	6.9	3.2	2.8
1	16	8	4.15	3.6
1-1/2	20	10	6.0	5.2
2	24	12	7.8	6.8
3	34	17	11	9.6
5	56	28	17.5	15.2
7-1/2	80	40	25	22
10	100	50	32	28
20			62	54
40			120	104

Compiled from N.E.C. manual.

To use the full capacity of the generator without tripping its circuit breaker(s), start the motors in the load one at a time, highest starting current motor first, next highest second, etc. Use the preceding table as a source of general information about motor running current requirements. For more specific information, see motor nameplate or motor manufacturer's catalog.

PRE-START CHECKS

WARNING: Personal Injury

When working on or around these generators, do not wear loose fitting clothing or any articles that may get caught in moving parts.

1. Visually inspect the generator. Check for:

- a. Correct mounting
- b. Physical damage
- c. Debris in cooling vents and screens (could cause generator to overheat).

IMPORTANT: The manufacturer recommends that, if the generator has been stored for any length of time, before using it, the operator remove the control box cover and cooling fan screen, then inspect the generator for rodent nests or other objects that could cause generator binding and/or overheating. See "Cleaning" portion of Maintenance section.

2. Check gear case oil level. (See Figure 6.) Case should be filled with oil to plug marked "OIL LEVEL." Fill or remove oil as required.

NOTE: EITHER TOO LITTLE OR TOO MUCH OIL CAN HARM THE EQUIPMENT.

See "Lubrication" portion of Maintenance for oil specifications.

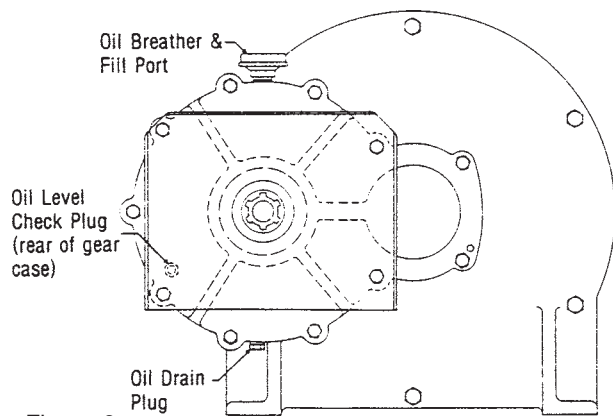

Figure 6

3. Make sure the drive shaft (tumbling bar) is assembled with its universal joint knuckles "synchronized," as illustrated in Figure 7. If knuckles are not synchronized, the bar will chatter when rotating, which will cause the generator output voltage to flicker.

DANGER: Personal Injury

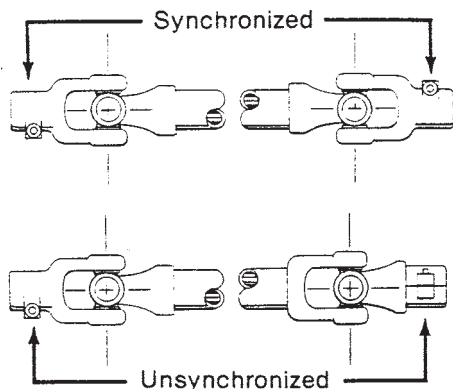

Figure 7

POWER TAKE-OFF MUST BE DISENGAGED AT THIS TIME.

4. Couple the tractor to the generator with the drive shaft (tumbling bar). Couple the tumbling bar to the generator input shaft first, then to the power take-off shaft. Check alignment, tractor, power take-off shaft (tumbling bar), and generator input shaft should form a straight (or nearly straight) line, with less than 15° misalignment between the shafts. Misalignment will cause generator output voltage to flicker.

CAUTION:

Make sure that all tumbling bar lock pins are engaged and that all safety shields are in place before operating the PTO generator.

5. Make sure no binding exists in generator or gear box. If binding is found, locate the cause and correct it before proceeding.
6. Make sure that the electrical loads to be driven by the generator will not draw more current than the ratings of the generator receptacle or cord set which will supply the current.
7. Check all electrical connections in the system to be

energized by the generator. Make sure the connections are correct and are tight.

8. Make sure all loads are turned off. Do not start the generator under load.

GENERATOR STARTING PROCEDURE

1. With the power take-off drive disengaged, start the engine which will drive the generator. Run the engine long enough to warm it up before proceeding, so that it will run smoothly and achieve full power under generator load.
2. With engine idling, engage the power take-off drive.
3. Watch the voltmeter on the generator and slowly increase engine speed until the output reaches approximately 260 volts (in green portion of voltmeter scale). For 208 volt generators the output should reach 215 to 220 volts.
4. With engine and generator running smoothly, switch on the electrical load while watching the voltmeter.

NOTE: Equipment Damage

If the load includes motors turn them on one at a time, highest starting current motor first, next highest second, etc.

Readjust engine throttle to keep generator output under load at 240V or 208 depending on the generator (in green portion of voltmeter scale). If engine is equipped with speed governor, it may automatically readjust the throttle as the load changes and keep the generator output at the proper level. However, some governors are not sensitive enough to maintain proper output under changing load, and in such cases the throttle will have to be manually readjusted .

GENERATOR SHUTDOWN PROCEDURE

1. Switch off electrical load.
2. Reduce speed of engine driving generator to idle.
3. Disengage power take-off drive, and allow generator to coast to a stop.

WARNING: Personal Injury

Never try to manually stop the generator. Always let it coast until it stops.

5. Shut off the engine.
4. Disconnect drive shaft (tumbling bar) power take-off end first, then generator end.

MAINTENANCE

The following chart lists various symptoms of poor generator operation with possible causes for them and the appropriate corrective action. You will need a volt-ohm meter or test light to check some of the causes. For some of the other causes you will need to check generator speed. To check generator speed you can use a frequency meter, a tachometer, or a 120V-60Hz electric clock and a correctly operating wrist watch. (Run the electric clock on generator power and compare the clock's second hand movement with that of the wrist watch. They should run at the same speed. If clock runs faster, generator speed is too high, and vice versa.)

CAUTION: Equipment Damage

Most electrical equipment in North America operates satisfactorily at frequencies between 59 and 61 Hz (cycles per second.) Operating the generator at frequencies outside that range may cause damage to the generator and/or to electrical equipment driven by the generator.

GENERAL

Routine preventive maintenance minimizes costly repairs and generator down-time. Before each use, inspect the generator: gear case oil level should be correct, cooling vents and screens should be clear, and generator mounting hardware should be tight. Clean and inspect the generator after storing it for long periods, and after using it in extremely dusty conditions or in severe weather, such as rain or blowing snow.

LUBRICATION

The generator bearings are factory lubricated and sealed, and require no further lubrication.

The splined generator input shaft should be cleaned and lubricated with a thin film of grease before and after each use of the generator.

The drive shaft (tumbling bar) requires greasing. Keep the universal joints in the coupling shaft free from grease and dirt buildup.

NOTE:

Do not over lubricate the universal joints.

See Figure 8 for recommended lubrication schedule for the coupling shaft.

Check the generator gear case oil level before each use of the generator. Maintain the oil level at oil level plug height. (Figure 6 illustrates oil level plug location.) The generator is shipped with lubricant in the gear case. Specifications for gear case lubricant are:

API Service: GL-5
Grade: SAE 85W-90-140
Amount: 1 pint

The following kinds of oil are recommended for use in the generator gear case: Mobil SAE 85W90-140 API Service GL-5, Sunoco/DX XL80W90-140 Kendal Three Star 85W-140, Amoco 85W140 or equivalent.

CAUTION: Equipment Damage

Do not overfill generator gear case. Overfilling causes overheating and oil seal failure.

Change the oil at least once every six months. Change it more often if you use the generator in bad weather. Use the following procedure to change generator gear case oil (see Figure 6):

1. Remove gear case breather. Soak breather in cleaning solvent, then allow it to dry.
2. Remove oil level check plug.
3. Remove the oil drain plug, drain the oil into a clean oil resistant container, 1 quart or larger. Check the oil for metal. Fine metal dust in the oil does not indicate trouble, but metal chips do. Dismantle the gear case and look for damaged gears if you find metal chips in the oil.
4. Replace the oil drain plug. Refill the gear case through the breather port with new oil of the recommended type. Fill the case up to oil level check plug height. (It will take about 1 pint.)
5. Replace the oil level check plug.
6. Replace the breather.

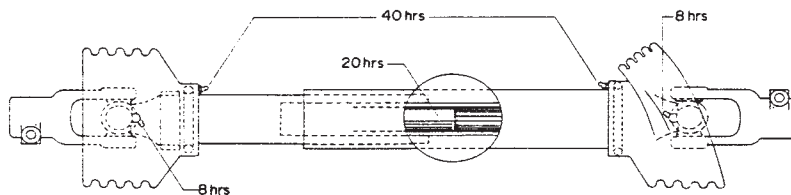

Figure 8

CLEANING & INSPECTING THE GENERATOR

Use a vacuum cleaner or dry low pressure compressed air (regulated at 25-35 PSI) to clean the generator periodically.

WARNING: Equipment Damage

DO NOT CLEAN THE GENERATOR WHILE IT IS RUNNING.

Proceed as follows:

1. Remove ventilated control box cover. Vacuum or blow vents and screen clear of dust or debris. Wash them down with cleaning solvent if necessary.

2. Remove cooling fan shroud. Vacuum or blow dust from screen and fan blades. Wipe them off with cleaning solvent if necessary.

3. Vacuum or blow dust and other debris from inside generator and control box.

4. With panel cover removed, inspect the brushes for wear, and inspect the wiring for correct routing, fraying insulation, and secure connections.

5. Replace panel cover and cooling fan shroud.

GENERATOR STORAGE

Before storing the generator, apply a heavy coat of grease to the splined input shaft. Store the generator in a sheltered area, where it is protected against snow, rain, and excessive dust.

TROUBLE SHOOTING TABLE

SYMPTOM	CAUSE(S)	CORRECTIVE ACTION
No output voltage.	1. Circuit breaker open.	1. Reset circuit breakers, replace if defective.
	2. Defective voltmeter.	2. Check output with another meter, replace meter if defective.
	3. Short circuit in the load.	3. Disconnect the load. Check voltage at receptacle cord set. Check motors, appliances and load leads for short circuit. Repair short.
	4. Defective receptacles.	4. Remove panel cover and check for voltage to the receptacles. Replace defective receptacles.
	5. Loose (or broken) wires or connections in control box.	5. Remove panel cover and check all wiring and connections. Tighten and/or repair where necessary.
	6. Defective rectifier.	6. Test rectifier. Replace if defective.
	7. Dirty slip rings.	7. Clean and polish. Use 00 sandpaper or crocus cloth, never use emery paper.
	8. Brushes binding in holders.	8. Check brushes for swelling; replace defective brushes; clean brush holders.
	9. Shorted or open rotor.	9. Measure rotor resistance. Replace rotor if open or shorted.
	10. Shorted or open stator.	10. Measure between leads for open or short. Replace stator if defective.
	11. Open transformer.	11. Connect or tighten primary and secondary leads. Check secondary for open circuit. Replace transformer if defective.
	12. Rotating field polarity incorrect.	12. Check by interchanging F (—) and F (+) leads at the brushes. Inner slip ring is positive F (+) and must be connected to the (+) terminal of the rectifier. Flash the field with 12 volts DC.
Low voltage.	1. Engine speed too slow.	1. Check engine speed. Increase RPM if necessary.
	2. Generator overloaded.	2. Reduce load if it is higher than the rated capacity of the generator. (See generator nameplate).
	3. Inadequate engine horsepower.	3. Generator requires 2 HP/1000 watts output. Obtain larger engine if necessary.
	4. Incorrect field excitation. (No-load output low.)	4. Check for worn brushes and weak or broken brush springs; replace as required. Check input AC voltage to rectifier. Check rectifier output DC voltage to positive DC brush. If no DC voltage is present at the brush, replace the rectifier. Check for dirty slip rings. Clean them if they are dirty.
	5. Connection of current transformer secondary leads not correct.	5. Have qualified service technician recheck and correct the connections.

SYMPTOM	CAUSE(S)	CORRECTIVE ACTION
High voltage.	<ol style="list-style-type: none"> 1. Engine speed too fast. 2. Connection of current transformer secondary leads not correct. 	<ol style="list-style-type: none"> 1. Check engine speed for correct input RPM. 2. Have qualified service technician recheck the connections.
Output voltage flickering or fluctuation.	<ol style="list-style-type: none"> 1. Tumbling bar (coupling shaft) misalignment. 2. Engine speed not constant. 3. Loose connection in field circuit. 4. Tumbling bar U-joints not synchronized. 	<ol style="list-style-type: none"> 1. Reduce tumbling bar misalignment to less than 15 degrees. 2. Engine governor may be worn or improperly adjusted. Set or repair defective governor. 3. Check and tighten connections. 4. Reassemble tumbling bar; see Figure 7.
Excessive vibration.	<ol style="list-style-type: none"> 1. Power take-off misalignment excessive. 2. Loose mounting nuts and bolts or hold-down studs. 3. Universal joints in coupling shaft worn or dry. 4. Defective bearings. 	<ol style="list-style-type: none"> 1. Correct misalignment. It should be less than 15 degrees. 2. Tighten mounting nuts and bolts; repair hold-down stud mountings. 3. Repair or replace defective parts. 4. Check for possible causes. Replace defective bearings.
Generator overheating.	<ol style="list-style-type: none"> 1. Poor ventilation. 2. Generator overloaded. 3. Shorted turns in field or stator windings. 	<ol style="list-style-type: none"> 1. Clean ventilation and cooling fan screens. 2. Reduce load, then check voltage and current. 3. Replace defective components.
Oil leak.	<ol style="list-style-type: none"> 1. Loose plug in gear case. 2. Defective seal, gasket, or plug in gear case. 	<ol style="list-style-type: none"> 1. Tighten plug. 2. Replace seal(s), gaskets or plugs. Maintain correct oil level.



THREE YEAR P.T.O. DRIVEN ALTERNATOR LIMITED WARRANTY

Winpower Inc. hereinafter referred to as Winpower, warrants for a period of three years to the original user that each Winpower PTO driven alternator is free from defects in material and factory workmanship if properly installed, serviced and operated under normal conditions according to Winpower's published instructions.

Manufacturer's obligation under this warranty is limited to correcting without any labor or material charge to the user for the first year of the said three years at its factory, or at its authorized repair centers, any part or parts which shall be returned and which upon examination shall disclose to Winpower's satisfaction to have been originally defective in material or in workmanship.

After one year and for a subsequent period of two years Winpower will warranty the cost of parts. The cost of labor involved in repairing or replacing parts will be borne by the user. Winpower shall not be liable for any incidental and consequential damage.

All transportation charges on parts or units submitted for replacement or repair to the factory or authorized repair centers under this warranty must be borne by the purchaser. This warranty does not apply to items which are subject to normal wear or any part or parts which have been subject to misuse, negligence, accident or which have been repaired or altered by other than persons authorized by Winpower.

Winpower shall not be liable for loss, damage or expense directly or indirectly from the use of its product nor for the fitness of product for any specific application or particular purpose.

There is no other express warranty. Winpower hereby disclaims any and all implied warranties, including but not limited to those of merchantability and fitness for a particular purpose to the extent permitted by law.

This warranty is effective only for all PTO driven alternators manufactured after December 15, 1997.

Note: If this alternator is used for standby service, this warranty is void unless a multi-pole, double throw switch is installed between the alternator and the service entrance switch. Do not operate PTO alternator without the shield installed.



*A Division of **DTI** Dyna Technology Inc*

P.O. Box 495, St. Peter MN 56082

Phone: 507-357-6707

Fax - 507-357-6580

Website: www.winpowerinc.com

e-mail: sales@winpowerinc.com