

Generating Quality



Since 1925

POWER-PAK[®]

Instruction Manual

GASOLINE ELECTRIC PLANT

AIR-COOLED

4000B/1



WINNER
NEW

INTRODUCTION

This manual covers the safety, operating and maintenance instructions for the WINPOWER line of air-cooled generator sets. Included as a part of the package is a parts list and wiring diagram covering the particular model you have purchased. The engine manufacturer's manual is also furnished with the set and gives the necessary operating and maintenance information for the engine.

GENERAL

The engine generator sets covered by this manual are of the single bearing type. The rotating member of the generator is mounted on a tapered extension of the engine crankshaft.

All sets have been thoroughly tested at the factory. The normal carburetor and engine speed adjustments have been made.

The set should be carefully inspected on delivery for evidence of possible shipping damage. If damage has occurred, a notation should be made on the freight bill and you should file a claim, if necessary. If the damage appears to be of a major nature, the set should not be operated until the fault has been corrected.

The model number and the serial number of the set must be given when contacting the dealer or the factory.

ELECTRICAL DESCRIPTION

The generators used in the WINPOWER line of air-cooled engine generator sets are revolving armature type.

The static, or electronic excitation system, uses rectifiers to change part of the output of the AC generator to DC for excitation of the field. On most models using static excitation, this system is extended still further by using current feedback through rectifiers in order to obtain increasing field strength with load increase to give better voltage regulation.

OPERATION

ENGINE STARTING

The engine manual should be followed in regards to operation. The engine crankcase must be filled with an oil recommended by the engine manufacturer. The fuel should be regular grade automotive gasoline. When filling the tank, allow for fuel expansion. Never fill tank when engine is running.

The carburetor choke should be adjusted as required by temperature conditions. When starting the generator, the operator should assume a stable stance to prevent injury in the event of engine kickback. Pull the start rope with a quick, smooth pull to crank the engine. Be sure to pull the rope completely through until it clears the starting pulley. After the engine starts, return choke to its normal position. In cold temperatures it may be necessary to keep the choke in the choke position longer.

HIGH MOISTURE CONDITIONS

The use of electrical equipment under extremely wet conditions should be avoided.

EXHAUST

Generator units must be operated in a well ventilated area to provide adequate cooling air for the engine and proper discharge of exhaust fumes.

STABILITY

Generator units should be placed on a solid level surface for proper engine operation. If there is any indication that the unit may shift during operation, the use of tie downs is recommended.

EXTENSION CORDS

The proper selection of an extension cord is necessary for optimum tool operation. Consult the following chart for proper wire size to carry the required load current. Voltage drops due to the extension cord should not exceed five volts.

WIRE SIZE		VOLTAGE DROP @ MAXIMUM AMPS FOR GIVEN WIRE LENGTHS			
<u>AWG</u>	<u>MAX. AMPS</u>	<u>25'</u>	<u>50'</u>	<u>75'</u>	<u>100'</u>
4	70	.87	1.74	2.60	3.48
6	55	1.08	2.17	3.25	4.35
8	40	1.25	2.51	3.87	5.03
10	30	1.50	3.00	4.50	6.00
12	25	1.98	3.97	5.95	7.95
14	18	2.27	4.55	6.82	9.10
16	13	2.65	5.22	7.84	10.45

MAINTENANCE

ENGINE

Refer to engine manual.

GENERATOR

Check brush lengths after 500 hours of running and every 100 hours thereafter. If brush length is less than 1/2", the brush should be replaced with a new one.

SANDING BRUSHES

It is important that the brushes make good contact with the collector rings. When installing a new set of brushes, they should be sanded in by using 00 sandpaper.

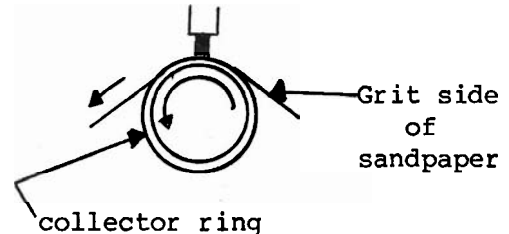

The sandpaper should be pulled in the direction of rotation. When pulled in the opposite direction to start a new stroke, the brush should be raised. Continue the sanding until the brushes are fully seated. Do not use emery cloth.

The collector rings should be cleaned if dirty.

Dirt and the moisture it will hold are detrimental to generators. If dust and dirt accumulate, the generator should be cleaned periodically.

THE FOLLOWING SERVICE PROCEDURES SHOULD BE PERFORMED BY AUTHORIZED WINPOWER SERVICE CENTERS OR OTHER QUALIFIED PERSONNEL.

TESTING FOR OPEN CIRCUITS

TESTING

The most likely place for an open circuit to occur is the shunt field circuit. The shunt field is connected to the rectifier output. One end of the shunt field should be disconnected. An ohmmeter reading should be taken between the disconnected end and the other end to determine continuity. If no reading is obtained there is an open circuit. Its exact location should then be determined and the open circuit should be repaired. The output leads should be checked for continuity.

RESTORING RESIDUAL MAGNETISM

PROCEDURE

It can be done by applying DC voltage (6-24 volts) across the terminals of the shunt field. Care must be taken that the polarity is correct. Incorrect polarity will destroy the diodes in the rectifier bridge if a limiting resistor is not used.

TESTING RECTIFIERS AND DIODES

DEFINITIONS

A diode is a single rectifying element represented graphically as shown below:



When a diode is used alone such as in half wave rectification it can also be called a rectifier. Two diodes are used in full wave rectification as shown:

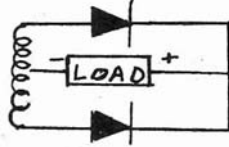

Four diodes are used in a single phase rectifier bridge as shown:

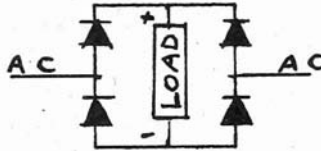

TESTING

An ohmmeter is required for testing a diode or rectifier assembly. It is necessary to remove the leads going to the rectifier for testing it. A single diode will show a very high resistance in one direction and low resistance in the other direction.



Low Reading



Very High Reading

A shorted diode will have a low reading in both directions. An open diode will have a high reading in both directions. Each diode in an assembly can be tested as shown below:

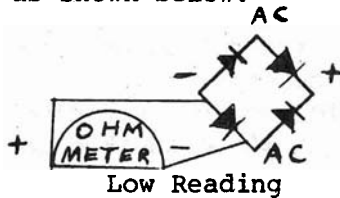

Low Reading

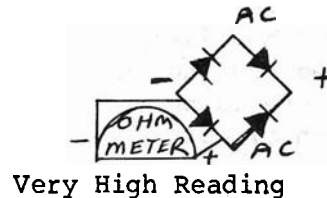

Very High Reading

This reading has to be repeated on every diode.

If the rectifier assembly is a molded assembly, test as follows:

Using a volt-amp-ohm meter (multi meter), check the rectifier assembly in the following sequence:

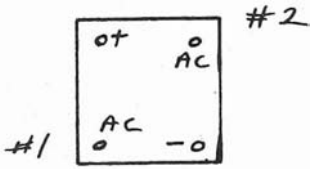

For purposes of order in checking, consider one AC terminal as #1, the other as #2.

<u>Check Between</u>	<u>Expected Resistance Reading</u>
+ Meter lead on + terminal - meter lead on AC #1	High
+ Meter lead on + terminal - meter lead on AC #2	High
+ Meter lead on - terminal - meter lead on AC #1	Low
+ Meter lead on - terminal - meter lead on AC #2	Low
+ Meter lead on AC #1 - meter lead on + terminal	Low
+ Meter lead on AC #1 - meter lead on - terminal	High
+ Meter lead on AC #2 - meter lead on + terminal	Low
+ Meter lead on AC #2 - meter lead on - terminal	High

If any readings do not comply with the above chart, the rectifier assembly is defective and should be replaced.

TROUBLE SHOOTING CHART

TROUBLE	CAUSE	REMEDY
No output voltage	<p>Loss of residual magnetism.</p> <p>Defective diode in rectifier bridges (see instructions for testing rectifier bridges).</p> <p>Poor brush contact (brush can be stuck in holder, worn or spring can be weak).</p> <p>Open circuit (see instructions for testing of open circuits).</p> <p>Shorted armature coils in revolving armature unit.</p> <p>Engine speed too low.</p>	<p>See instruction for restoring residual magnetism.</p> <p>Replace diode or rectifier assembly.</p> <p>Free brush if stuck. Replace with new brush if worn. Replace brush spring if weak.</p> <p>Complete circuit if in external wiring.</p> <p>Replace armature</p> <p>Adjust engine speed to correct value.</p>
Low output voltage at no load.	<p>Low engine speed.</p> <p>Shorted diode (see instructions for testing rectifier bridge).</p>	<p>Adjust engine speed to correct value.</p> <p>Replace diode or rectifier assembly.</p>
Voltage O.K. at no load but drops off rapidly on load application.	<p>Shorted diode in series field bridge (see instructions for testing rectifier bridge).</p> <p>Engine speed drops off rapidly.</p>	<p>Replace diode or rectifier assembly.</p> <p>See engine manual.</p>
High output voltage	<p>Excessive engine speed</p>	<p>Adjust engine speed to correct value.</p>
Excessive generator heating.	<p>Overload on generator.</p> <p>Clogged ventilating inlets and/or outlets.</p>	<p>Reduce load.</p> <p>Clean inlets and outlets.</p>
Arcing at brushes	<p>Brushes not seated properly.</p>	<p>See instructions for sanding brushes.</p>

ECON-O-MIZER MAGNET ADJUSTMENT INSTRUCTIONS

1. Place Economizer switch in off position, start engine.
2. Manually push Economizer arm on carburetor up or down to reach an idle speed, adjust engine idle set screw cw to reach 50-60 volts AC at 120 volt receptical.
3. Stop engine, adjust magnet up or down so that it just touches the Economizer arm. While holding the arm in idle position, tighten magnet into this position.
4. Turn idle set screw one-half turn ccw so that screw does not touch stop on carburetor when arm is against magnet. Adjustment is complete.
5. If Economizer will not hold at idle, off load and switch turned on, adjust the magnet farther from the carburetor arm.

		MODEL TYPE	OB/1 1	MODEL 4000B/EI TYPE 1	
REF.	PART DESCRIPTION	PART NO.	REQ'D	PART NO.	REQ'D
N.S.	Engine B & S 190432 Elec.			EC-11602-6	1
N.S.	Engine B & S 190432	EC-11602	1		
1	Shock Mount	W-208	4		
2	Gen Support	S-7423-1	1		
3	Skid Channel	S-7280-3	2		
4	Stud	S-6657-3	4		
5	Drive End Bell	A-813	1		
6	Armature	G-6359-17	1		
7	Bearing	D-5	1		
8	Field Frame	G-7511-1	1		
9	Field Coil Straight	H-1315	1		
10	Stud	S-8610-57	1		
11	End Hood	S-7589	1		
12	Lift Eye	S-9566	1		
13	Rectifier - Shunt	EE-2214	1		
14	Brush	Y-51	3		
15	Brush Gear	G-6016-8	1		
16	Bursh Spring	G-3422	3		
17	Fan	A-798	1		
18	Rectifier - Series	EE-2214	2		
19	Field Pole	G-5592	2		
20	Coil Shield	J-573	4		
21	Field Coil Cross	H-1316	1		
22	Panel Box	G-7417-1	1		
23	120 Volt Receptacle 5-15R	EE-323-1	1		
24	240 Volt Receptacle L6-20R	EE-1371	1		
25	120 Volt Receptacle L5-30R	EE-1372	1		
26	Panel Front	S-9563-2	1		

Parts Drawing IE-11510-2 Wiring Diagram
IE-11908-3

Wiring Diagram IC-7145

NOTE: Part Numbers and Quantity are the same in
all columns, but for the exceptions.

PL-2536

1E-11510-2

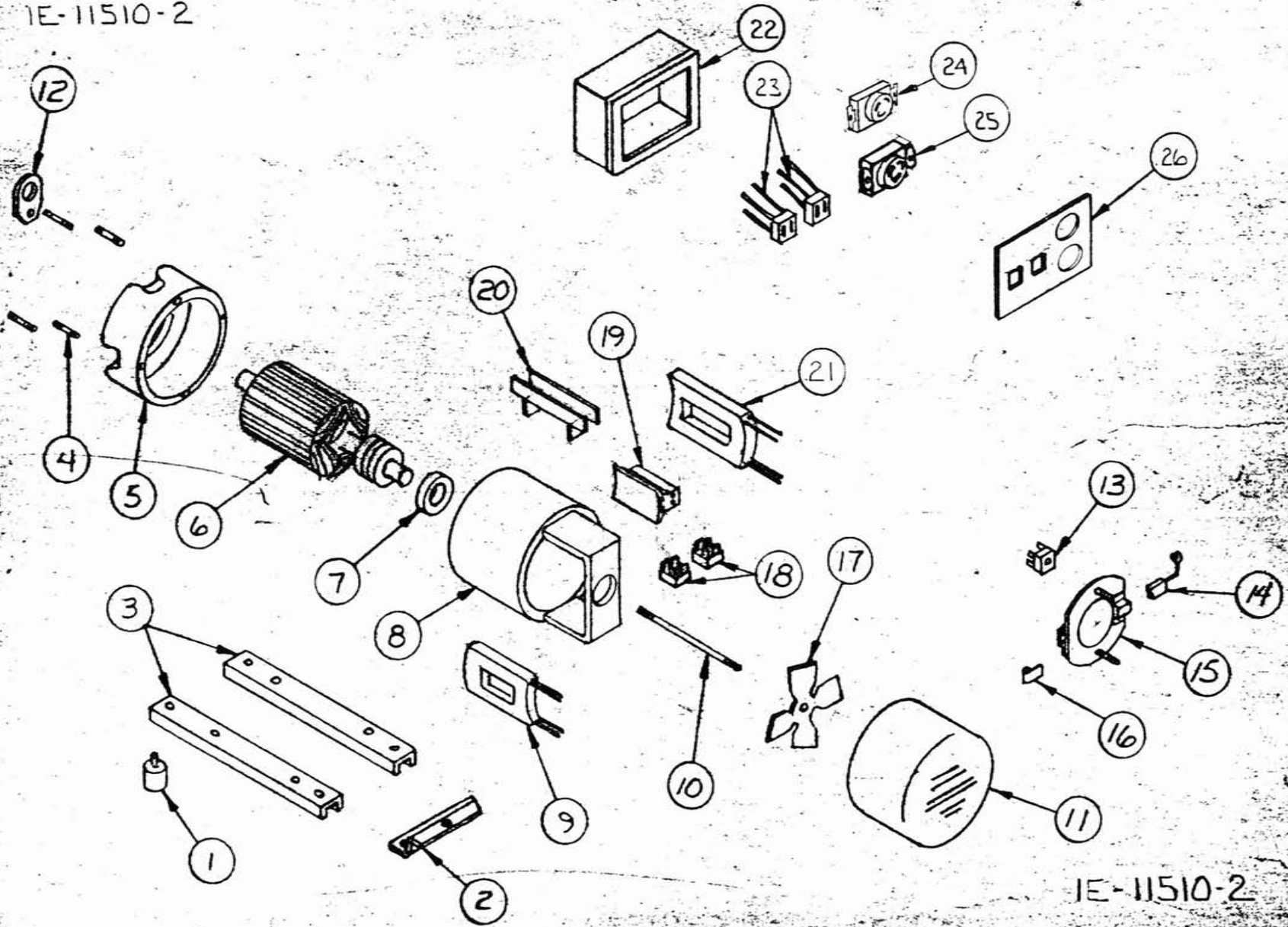

1E-11510-2

IE 11908-3

NOTICE: THIS DOCUMENT IS CONFIDENTIAL AND IS THE PROPERTY OF WINPOWER CORPORATION, NEWTON, IA. IT MUST NOT BE USED IN ANY WAY DETRIMENTAL TO OUR INTEREST. REPRODUCTION OF ITS CONTENT BY ANY MEANS OR IN ANY FORM WITHOUT EXPRESS PERMISSION OF THE WINPOWER MANAGEMENT IS PROHIBITED.

REVISIONS				
LTR	DESCRIPTION	DATE	BY	APPROVED

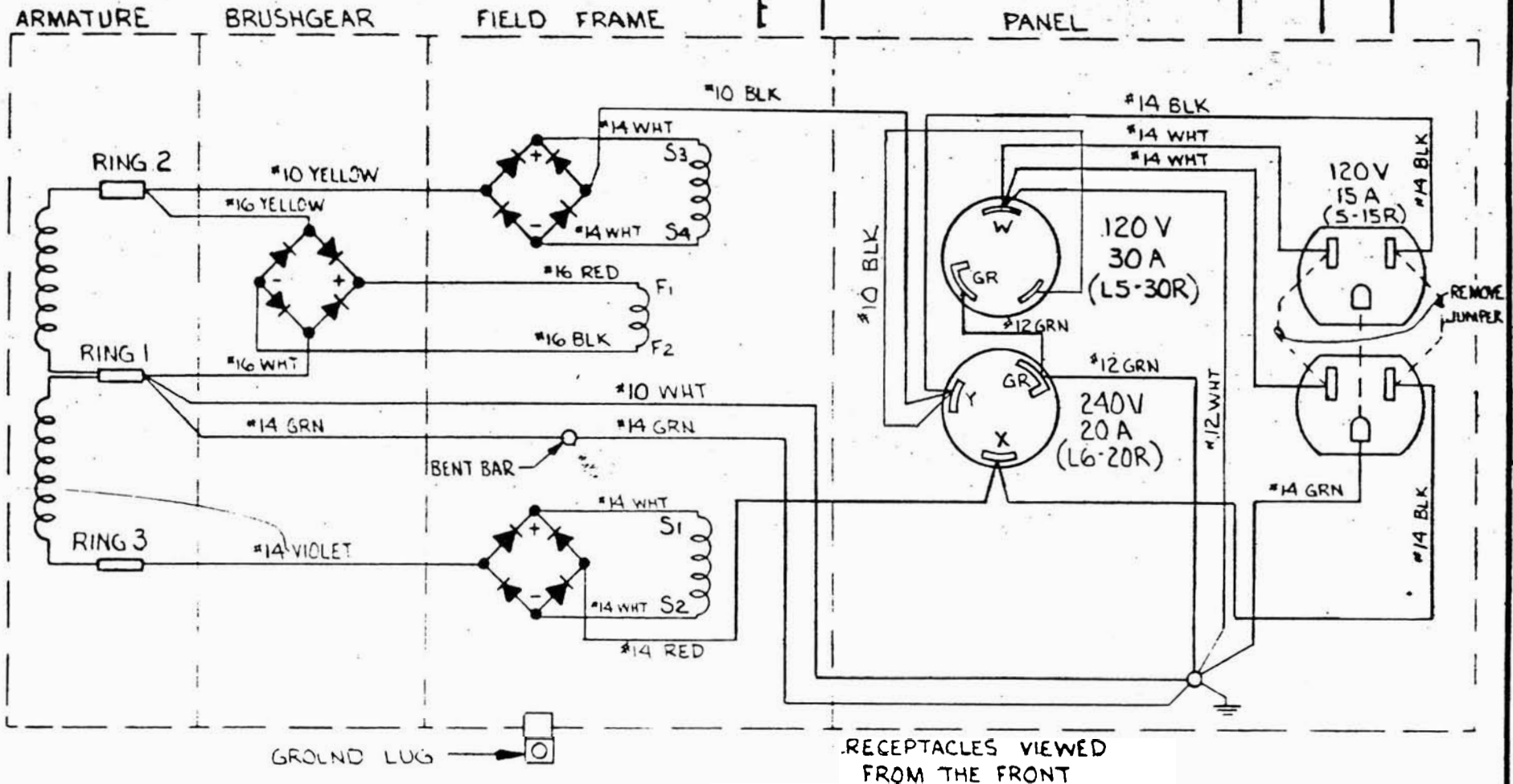

RECEPTACLES VIEWED FROM THE FRONT

REF. 40003/1 4000B/E1

REF	PART NO	SZ	DESCRIPTION	QTY.
PARTS LIST				

SYMBOLS PARALLELISM ⊕ POSITION ○ ROUNDNESS = SYMMETRY - STRAIGHT ⊙ CONCENTRICITY □ FLATNESS < ANGULARITY ⊥ PERPENDICULARITY		MATERIAL DRAWN BY: GRS PROJ ENG: MICROFILM DATE:		DO NOT SCALE WINPOWER CORPORATION NEWTON, IOWA 50208	
TOLERANCE ON DIMENSIONS NOT OTHERWISE SPECIFIED		DECIMAL ± FRACTIONAL ± ANGULAR ±		TITLE: WIRING DIAGRAM PART NO: IE-11908-3 SIZE A REV: SCALE: ~ DATE: 3 MAY 85 SHEET:	

IE-11908-3