

THIS CONNECTOR CAVITY MUST HAVE A CONTACT INSERTED, EVEN THOUGH THERE ISN'T A WIRE INSTALLED FOR SINGLE PHASE APPLICATIONS.

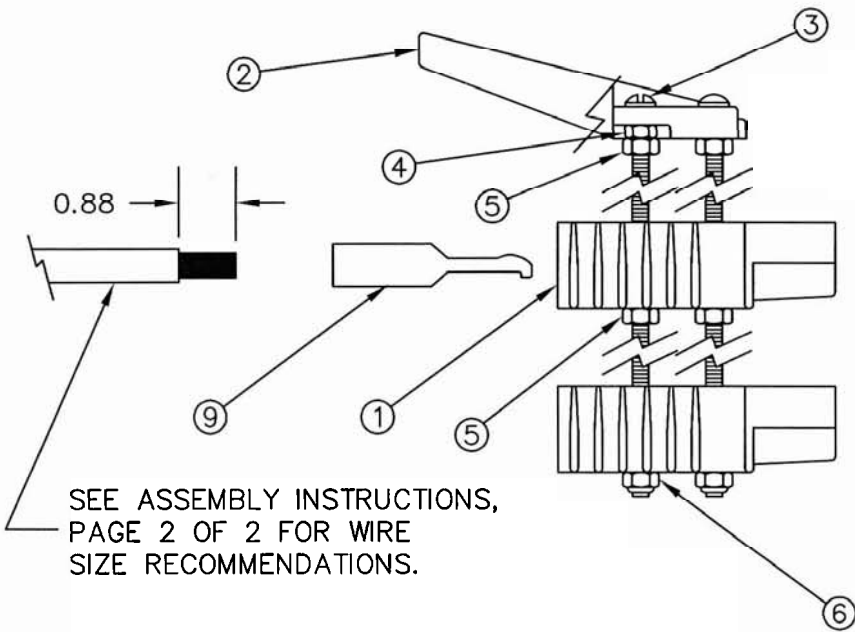

SEE ASSEMBLY INSTRUCTIONS, PAGE 2 OF 2 FOR WIRE SIZE RECOMMENDATIONS.

9	EE23323	4	CONTACTS
8	BP-10099-101	1	INSTRUCTION SHEETS (BP-10099 PAGE 1 & PAGE 2)
7	BS6	1	POLY BAG
6	A-47517-000	2	NYLOCK 1/4-20
5	458-000	4	HN 5/16-18
4	638-000	1	HN 1/4-20
3	A-61993-001	2	RHMS 1/4-20 x 3 1/2
2	EE-2329	1	HANDLE
1	EE-2331	2	HOUSING
ITEM	PART NO	QUAN.	DESCRIPTION

INSTRUCTIONS
PAGE 1 OF 2

ISSUE E

BP-10099-101

ASSEMBLY INSTRUCTIONS

1. READ INSTRUCTIONS COMPLETELY PRIOR TO ASSEMBLING THE CONNECTOR.
2. VERIFY THAT ALL ITEMS AND THE CORRECT QUANTITIES ARE IN THE PACKAGE BY CHECKING OFF EACH ITEM AGAINST THE BILL OF MATERIAL SHOWN ON PAGE ONE.
3. INSTALL CONTACTS INCLUDED WITH ITEM 1 ON THE ELECTRICAL CONDUCTOR (SEE THE CONDUCTOR RECOMMENDATIONS BELOW) BY SOLDERING, USING A GOOD GRADE OF RESIN CORE SOLDER OR AN APPROPRIATE COMPRESSION CRIMPER AS RECOMMENDED BY WINPOWER.
WARNING: SOLDER ONLY COPPER CONDUCTORS AND NEVER USE ACID CORE SOLDER!
4. ASSEMBLE ITEMS 1,2,3,4,5,&6 EXACTLY AS PICTURED ON PAGE ONE. THIS MAKES THE PORTABLE PLUG ASSEMBLY WITHOUT THE CONDUCTORS.
5. INSERT THE CONDUCTORS WITH THE INSTALLED CONTACTS INTO THE PROPER CAVITIES AS SHOWN ON SHEET ONE. NOTE THAT ONLY THREE OF THE CAVITIES HAVE CONDUCTORS WITH CONTACTS, WHILE THE FOURTH CAVITY HAS ONLY A CONTACT WITHOUT AN ATTACHED CONDUCTOR.

LEAD WIRE RECOMMENDATIONS

LEAD WIRE TYPE	MODEL 110/100 PTAM
NEOPRENE	4/0
VINYL/HYPALON	4/0
150°C EPDM/SILICONE	3/0 (SEE NOTE 2)
200°C EPDM/SILICONE	3/0 (SEE NOTE 2)

NOTES:

- 1 - SIZES ARE BASED UPON A MAXIMUM LEAD LENGTH OF TEN FEET, IN FREE AIR AND A MAXIMUM AMBIENT TEMPERATURE OF 30°C(86°F). GREATER LENGTHS OR HIGHER TEMPERATURES MUST BE REVIEWED FOR VOLTAGE DROP AND REDUCED AMPACITY. THIS MUST BE DONE PER RECOMMENDATIONS OF THE NATIONAL ELECTRIC CODE, LOCAL CODES OR REGULATING BODIES THAT ARE IN AFFECT FOR THE INSTALLATION.
- 2 - 3/0 CONTACTS REQUIRED, WINPOWER PART NO. EE2332-2.

CRIMPING TOOLS:

1. ANDERSON POWER PRODUCTS
2. ETC MODEL HHS HYDRAULIC CRIMPER
3. ITT BLACKBURN NO. 1640

BP10099

BAG/PARTS 110/100PTAM

Level	Mtl	Used In	Part Number	Description	Revision	Alternate	Quantity	UOM
2	145	100/90PTAM-0		TRACTOR DRIVE W/PLUG KIT	F		1.00000	EA
2	160	100/90PTDM-0		TRACTOR DRIVE W/PLUG KIT	F		1.00000	EA
2	145	100/90PTLM-0		TRACTOR DRIVE W/PLUG KIT	B		1.00000	EA
2	140	110/100PTAM		TRACTOR DRIVE	F		1.00000	EA
2	155	110/100PTAM-0		TRACTOR DRIVE W/PLUG KIT	I		1.00000	EA
2	135	115/100PTAM-0		TRACTOR DRV~ 1000RPM W/PLUG KIT	F		1.00000	EA
2	145	115/105PTLM-0		TRACTOR DRV~ 1000RPM W/PLUG KIT	F		1.00000	EA
2	70	300134-2		KIT, 350A LOAD PLUG CONVERSION 150/	B		1.00000	EA
2	135	64864-000		W100FPTOS/A 1000RPM W/PLUG KIT	1		1.00000	EA
2	115	64864-002		W100FPTOSB	5		1.00000	EA
2	150	64867-000		W105FPTOT-4/A W/PLUG KIT	1		1.00000	EA
2	150	64867-001		W105FPTOT-17/A W/ PLUG KIT	1		1.00000	EA
2	150	64867-002		W105FPTOT-18/A W/PLUG KIT	3		1.00000	EA
2	115	64868-005		W165FPTOT-18B	3		1.00000	EA
2	150	64869-000		W75FPTOS/A~W/PLUG KIT	1		1.00000	EA
2	115	64869-002		W85FPTOSB	5		1.00000	EA
2	150	80/75PTAM-0		TRACTOR DRV~ 1000RPM W/PLUG	I		1.00000	EA
2	5	939541-000		W100FPTOS/A W/PMG	1		1.00000	EA
2	155	WP100FPTOS		100KW PTO/1000RPM~240V~1PH~W/PLUG K	A		1.00000	EA
2	115	WP100FPTOS/B		100kw 1000RPM 120/240V 2P W/PLUG KI	B		1.00000	EA
2	170	WP105FPTOTJ		105KW PTO/1000RPM~120/240V~3PH~W/PL	A		1.00000	EA
2	115	WP165FPTOT-18/B		165kw 1000RPM 277/480V 3P W/PLUG KI	B		1.00000	EA
2	150	WP75FPTOS		75KW PTO 1000RPM~1PH~4WIRE~W/PLUG K	A		1.00000	EA
2	115	WP85FPTOS/B		85kw 1000RPM 120/240V 3P W/ PLUG KI	B		1.00000	EA