



**DIESEL
GENERATOR**

**INSTALLATION AND
OPERATIONS MANUAL**

DE20I4

DE30I4

DE45I4

DE65I4

SAVE THESE INSTRUCTIONS

This manual contains important instructions that should be followed during installation and maintenance of the generator and batteries.

Read and understand all instructions in the manual before starting and operating the generator set.

USING THIS MANUAL

Congratulations on your choice of a Winpower generator set. You have selected a high-quality, precision-engineered generator set designed and tested to give you years of satisfactory standby service.

To get the best performance from your new engine generator set, it is important that you carefully read and follow the operating instructions in this manual.

Should you experience a problem please follow the "Things To Check" near the end of this manual. The warranty listed in this manual describes what you can expect from WINPOWER should you need service assistance in the future.

COPY YOUR MODEL AND SERIAL NUMBER HERE

No other WINPOWER generator has the same serial number as yours. It is important that you record the number and other vital information here. If you should ever need to contact us on this unit it will help us to respond to your needs faster.

MODEL _____

SERIAL NUMBER _____

'M" Spec. _____

PURCHASE DATE _____

DEALER _____

TABLE OF CONTENTS

INTRODUCTION	i
GUIDE TO PRODUCT SAFETY	1
BASIC INFORMATION	2
Specification Table	2
Description	3
DSE702 Description	3
RECEIVING THE GENERATOR	3
Unpacking the unit	4
ENGINE GENERATOR INSTALLATION	
Installation	4
Engine Generator Set Mounting	5
Fuel Installation	5
Lubrication	6
Coolant	6
Battery Installation	6
AC Electrical Connections	7
AC Wiring Diagram	8
Engine Control Layout	9
DSE702 Control	10
INITIAL START-UP	10
TROUBLESHOOTING INFORMATION	11
LAYOUT DIAGRAMS	
DE2014	12
DE3014	12
DE4514	13
DE6514	13
DC SCHEMATIC - WIRING DIAGRAM	
DE2014 & DE3014	14
DE4514 & DE6514	15
AC WIRING - THREE PHASE	
277/480 Volt	16
120/208 Volt	16
120/240 Volt	17
AC WIRING - SINGLE PHASE	
120/240 Volt	17
12 MONTH WARRANTY	18

PROPER USE AND INSTALLATION

You must be sure your new engine generator set is:

- * Properly serviced before starting
- * Operated in a well ventilated area
- * Properly exhausted and gases safely dispersed
- * Wired by a qualified electrician
- * Operated only for its designed purposes
- * Used only by operators who understand its operation
- * Properly maintained

IMPORTANT SAFETY INSTRUCTIONS

SAVE THESE INSTRUCTIONS

This manual contains important instructions that should be followed during installation and maintenance of the generator and batteries.

Read and understand all instructions in the manual before starting and operating the generator set.

This engine generator set has been designed and manufactured to allow safe, reliable performance. Poor maintenance, improper or careless use can result in potential deadly hazards; from electrical shock, exhaust gas asphyxiation, or fire. Please read all safety instructions carefully before installation or use. Keep these instructions handy for future reference. Take special note and follow all warnings on the unit labels and in the manuals.

ANSI SAFETY DEFINITIONS

DANGER:

DANGER indicates an imminently hazardous situation which, if not avoided, will result in death or serious injury. This signal word is to be limited to the most extreme situations.

WARNING:

WARNING indicates a potentially hazardous situation which, if not avoided, could result in death or serious injury.

CAUTION:

CAUTION indicates a potentially hazardous situation which, if not avoided, may result in minor or moderate injury. It may also be used to alert against unsafe practices.

NOTE:

CAUTION is also used on the unit labels and in this manual to indicate a situation that could result in serious damage or destruction of the equipment and possible personal injury.

1. **ELECTRIC SHOCK** - The output voltage present in this equipment can cause a fatal electric shock. This equipment must be operated by a responsible person.
 - a. Do not allow anyone to operate the generator without proper instruction.
 - b. Guard against electric shock.
 - c. Avoid contact with live terminals or receptacles.
 - d. Use extreme care if operating this unit in rain or snow.
 - e. Use only three-prong grounded receptacles and extension cords.
 - f. Be sure the unit is properly grounded to an external ground rod driven into the earth.

2. **FIRE HAZARD** - Diesel fuel presents a hazard of possible explosion and/or fire.
 - a. Do not smoke or use open flame near the generator set.
 - b. Keep a fire extinguisher nearby and know its proper use. Fire extinguishers rated ABC by NFPA are appropriate.
3. **DEADLY EXHAUST GAS** - Exhaust fumes from any diesel engine contain carbon monoxide, an invisible, odorless and deadly gas that must be mixed with fresh air.
 - a. Operate only in well ventilated areas.
 - b. Never operate indoors.
 - c. Never operate the unit in such a way as to allow exhaust gases to seep back into closed rooms (i.e. through windows, walls or floors).
4. **NOISE HAZARD** - Excessive noise is not only tiring, but continual exposure can lead to loss of hearing.
 - a. Use hearing protection equipment when working around this equipment for long periods of time.
 - b. Keep your neighbors in mind when permanently installing this equipment.
5. **CLEANLINESS** - Keep the generator and surrounding area clean.
 - a. Remove all grease, ice, snow or materials that create slippery conditions around the unit.
 - b. Remove any rags or other material that could create potential fire hazards.
 - c. Carefully wipe up any fuel or oil spills before starting the unit.
 - d. Never allow leaves or other flammable material to build up around the engine exhaust area.
6. **SERVICING EQUIPMENT** - All service, including the installation or replacement of service parts, **should be performed only by a qualified technician.**
 - a. Use only factory approved repair parts.
 - b. Do not work on this equipment when fatigued.
 - c. Never remove the protective guards, cover, or receptacle panels while the engine is running.
 - d. Use extreme caution when working on electrical components. High output voltages from this equipment can cause serious injury or death.
 - e. Always avoid hot mufflers, exhaust manifolds, and engine parts. They all can cause severe burns instantly.
 - f. Installing a generator set is not a "do-it-yourself" project. Consult a qualified, licensed electrician or contractor. The installation must comply with all national, state, and local codes.
 - g. Always make sure unit is disabled before placing your hands anywhere near the fan, belts, alternator or water hoses.

TESTING POLICY:

Before any generator is shipped from the factory, it is fully checked for performance. The generator is loaded to its full capacity, and the voltage, current, and frequency are carefully checked.

Rated output of the generators is based on engineering tests of typical units, and is subject to, and limited by, the temperature, altitude, fuel, and other conditions specified by the manufacturer of the applicable engines.

SPECIFICATIONS

MODEL	DE2014-A	DE2014-D	DE2014-J	DE2014-L
Generator				
Wattage	20000	20000	20000	20000
Volts	120/240	120/208	120/240	277/480
Phase	single	three	three	three
PF	1.0	.80	.80	.80
AMPs	83.0	69.5	60.2	30.1
Hertz	60	60	60	60
Engine				
Model	Isuzu 4LE1			
Starting System	12 Volt Manual Start			
Muffler	Standard			
Stop System	Key/Emergency			
Fuel Consumption (full Load)	1.8 Gal/hour			
Owner Must Provide				
Fuel	ASTM D-975 - 1D or 2D EN590 or equivalent See engine manual for additional fuel types & specification			
Oil Type	10W-30 CC/CD			
See engine manual for additional oil information.				
Oil Capacity	8.6 Quarts			
Cooling System	50/50 Mix			

MODEL	DE3014-A	DE3014-D	DE3014-J	DE3014-L
Generator				
Wattage	30000	30000	30000	30000
Volts	120/240	120/208	120/240	277/480
Phase	single	three	three	three
PF	1.0	.80	.80	.80
AMPs	125	104	90	45
Hertz	60	60	60	60
Engine				
Model	Isuzu 4LE TurboCharged			
Starting System	12 Volt Manual Start			
Muffler	Standard			
Stop System	Key/Emergency			
Fuel Consumption (full Load)	2.6 Gal/hour			
Owner Must Provide				
Fuel	ASTM D-975 - 1D or 2D EN590 or equivalent See engine manual for additional fuel types & specification			
Oil Type	10W-30 CC/CD			
See engine manual for additional oil information.				
Oil Capacity	8.6 Quarts			
Cooling System	50/50 Mix			

MODEL	DE4514-A	DE4514-D	DE4514-J	DE4514-L
Generator				
Wattage	45000	45000	45000	45000
Volts	120/240	120/208	120/240	277/480
Phase	single	three	three	three
PF	1.0	.80	.80	.80
AMPs	187	156	135	68
Hertz	60	60	60	60
Engine				
Model	Iveco N45SM1			
Starting System	12 Volt Manual Start			
Muffler	Standard			
Stop System	Key/Emergency			
Fuel Consumption (full Load)	4.09 Gal/hour			
Owner Must Provide				
Fuel	ASTM D-975 - 1D or 2D EN590 or equivalent See engine manual for additional fuel types & specification			
Oil Type	10W-30 CF-CH4			
See engine manual for additional oil information.				
Oil Capacity	13.5 Quarts			
Cooling System	50/50 Mix			

MODEL	DE6514-A	DE6514-D	DE6514-J	DE6514-L
Generator				
Wattage	65000	65000	65000	65000
Volts	120/240	120/208	120/240	277/480
Phase	single	three	three	three
PF	1.0	.80	.80	.80
AMPs	271	226	195	98
Hertz	60	60	60	60
Engine				
Model	Iveco N45SM2 TurboCharged			
Starting System	12 Volt Manual Start			
Muffler	Standard			
Stop System	Key/Emergency			
Fuel Consumption (full Load)	4.57 Gal/hour			
Owner Must Provide				
Fuel	ASTM D-975 - 1D or 2D EN590 or equivalent See engine manual for additional fuel types & specification			
Oil Type	10W-30 CF-CH4			
See engine manual for additional oil information.				
Oil Capacity	13.5 Quarts			
Cooling System	50/50 Mix			

INTRODUCTION AND DESCRIPTION

PRODUCT DESCRIPTION:

This engine-generator set is designed for manual key start operation. The engine-generator set is fully tested at the factory prior to shipment to insure proper operation of each individual component as well as the total system's performance and reliability.

The engine generator set consists of a multi-cylinder, liquid cooled engine nominally operating at 1800 rpm. The generator frequency regulation is maintained by the engine governor to within +/- 1.5 hertz (cps), from no load to rated load for standard mechanical governors. The generator is a single bearing, direct drive, rotating field brushless design. The generator is connected to the engine flywheel via flexible drive disks. The Generator Set is skid mounted with isolation mounts between the engine and base on all units.

Unit Orientation Note: All references used in this manual for unit familiarization, access and component locations on the Generator Set are oriented from a TOP (plan) VIEW with engine at the FRONT and generator to the REAR.

A customer supplied 12 Volt battery is required to complete the installation. Battery requirements are listed later under the battery installation section.

The engine is controlled and monitored for safe operation by a manual operation Electronic Engine Control Module (ECM) with an LCD digital display. The generator set ECM control can be mounted on either the left or right hand side of the unit. All units are shipped with it mount on the same side of the unit as the oil dipstick for single side accessibility. The ECM is a DSE702 genset start controller.

GENERATOR SET:

Every WINPOWER Generator Set has its own unique identity data plate. This data plate identifies the complete unit model number, the system serial number and has links to the individual components that form the generator set in our factory records. Several of the major components also have their own individual identity plates providing additional information to document build data for warranty and replacement parts.

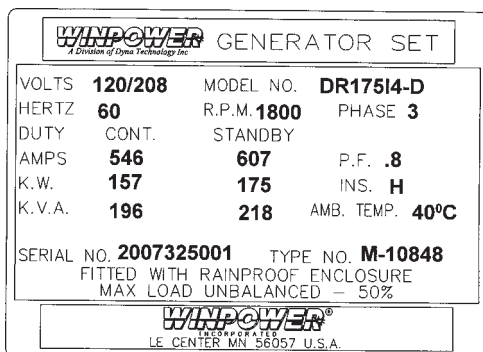

Typical Winpower Nameplate

Be sure to have the main WINPOWER unit data plate information recorded inside the front cover of this manual for future reference and for identification whenever requesting field or factory technical assistance. Sample data plate is shown for reference. Primary fields needed for assistance are complete model number, serial number and especially the M-Spec number. The M-Spec number (if provided) is recorded in the 'TYPE NO.' block on the Lower Right of the plate.

ENGINE:

This manual covers specific operation of the combined engine generator set. Refer to engine operating and maintenance instructions for specific instruction on the care and maintenance of the engine. Oil and fuel requirements along with maintenance schedules and engine warranty information are provided by the individual engine manufactures.

** CAUTION **

EQUIPMENT DAMAGE - Be sure to check the engine oil level frequently as specified in the engine manual.

The engine manufacturer has established an excellent worldwide engine service organization; engine service is available from a nearby authorized dealer or distributor; check the Yellow Pages of the telephone directory under "engines," or ask the dealer from whom you purchased the power plant.

The rated power of each engine-generator is limited by the temperature, altitude and all other ambient conditions specified by the engine manufacturer. Engine power will decrease 3-1/2% for each 1000 ft. above sea level, and will decrease an additional 1% for each 10 degrees Fahrenheit above 60 degrees Fahrenheit. Units should not be operated in ambient temperature greater than 125 degrees Fahrenheit.

GENERATOR:

WINPOWER Generators Sets use totally brushless, AVR (Auto-Voltage Regulator) controlled broad-range generator ends. The generator converts rotational mechanical energy into electrical energy. These WINPOWER units are equipped with generators manufactured by MECC ALTE SPA. Each generator 'end' has its own data tag. A unique serial number is stamped on the data plate and the data label is affixed to the main frame of the generator on the left side.

ENGINE CONTROL MODULE (DSE702)

The DSE702 start control module is a basic push button manual start controller. It has a removable key for additional security. The controller has three safety shutdowns built into it for engine protection along with a glow plug circuit for engine requiring that feature.

Engine protection features include low oil pressure and high coolant temperature monitoring. As well as overspeed shutdown protection. It also comes with a starter lock out that prevents the starter from being engaged or staying engage once the generator achieves 20% of desired frequency.

RECEIVING THE GENERATOR

The generator set will generally be shipped by a commercial 'common freight carrier'. Routing is determined by the bulk, size, and a means available to unload the generator at the receiving end. WINPOWER recommends units that are shipped by common carrier be delivered to a commercial dock to allow the Generator Set to be unloaded in a safe, efficient manner and to minimize handling damage to the unit.

Locate the packing slip on the side of the crate or request it from the truck driver. When receiving the unit take special care in examining the unit for damage during shipment. Avoid signing for the equipment until a full visual assessment and inventory have been made. Verify that you have received the right equipment and the proper amount by matching up the equipment to the packing list.

UNPACKING INSTRUCTIONS:

When unpacking the generator set, be sure to inspect it carefully for freight loss or damage. If loss or damage is noted at the time of delivery, require that the person making the delivery make note of the loss or damage on the freight bill, or affix his signature under the consignee's memo of the loss or damage. Contact the carrier for claim procedures.

When loss or damage is noted after delivery, segregate the damaged material, and contact the carrier for claim procedures.

"Concealed Damage" is understood to mean damage to the contents of a package which is not in evidence at the time of delivery by the carrier, but which is discovered later. The carrier or carriers are responsible for merchandise lost or damaged in transit. The title to goods rests with the consignee when generators are shipped fob factory, and only the consignee can legally file a claim.

***** CAUTION ****

EQUIPMENT DAMAGE - These units are shipped with oil, and a 50/50 mix of coolant. Be sure to check all fluid levels before operating. See engine manufacturer's instruction manual for recommended oil requirements before initial starting.

UNPACKING:

(Not recommended until the unit is on-site)

1. Carefully remove the crate.
2. After inspecting the engine-generator for external physical damage, locate and check the following items packed with the unit.
 - a. Owner's operators manual.
 - b. Engine manufacturer's instruction manual.
 - c. Battery hold-down brackets & hardware.
 - d. Unit components or accessory items shipped loose for on-site installation.
 - e. Optional accessories.

3. Remove main frame hold down bolts.
4. Unit can now be lifted from shipping rails.

LIFTING THE GENERATOR SET

NOTICE - Personal Injury

To prevent injury to persons or equipment, observe the following guidelines when lifting the generator:

Due to the different designs, configurations, options, weights, site conditions, and available material handling equipment, specific lifting instructions are not provided for each individual generator set model. General guidelines provided are applicable to the entire standby generator line. It is the responsibility of the installing party to follow the lifting equipment's operators manual to prevent injury to personnel and damage to the generator. Smaller Generator Sets may not require use of overhead lifting equipment and may be placed on the pad with basic material handling equipment, i.e. a forklift.

CAUTION: - Do not attempt to lift the generator set by the means of the lifting eyes on the engine or generator end.

These lifting points are only for use during the manufacturing process and are designed for lifting of the individual Generator Set component.

***** WARNING ****

NEVER - attempt to lift the fuel tank while filled with fuel. Sloshing of the fuel can cause a shift in the balance of the fuel tank, making for a DANGEROUS, unbalanced lifting load. If the generator was shipped on the fuel tank, use the lifting points located on the fuel tank to move the entire Generator Set into place. DO NOT place fuel in the tank prior to lifting.

INSTALLATION

***** WARNING ****

PERSONAL INJURY - Before proceeding with the installation, be sure the engine control is in the "stop" position. Before proceeding with the installation, be sure the Generator MLCB (Main Line Circuit Breaker) is in the 'OFF' position and the unit starting battery is disconnected.

GENERAL INFORMATION

This series of engine/generator sets are designed and build as open power unit, meaning no weather protection has been provide. These unit must be installed inside of an enclosure that will provide proper protection from the elements.

Before beginning the installation process, recheck the voltage, phase and amperage rating of the Generator Set. Be certain it can handle the intended load and are compatible with the intended loads. Plans for installation should be prepared with proper attention to mechanical and electrical engineering detail to assure a satisfactory system installation. **The installation must comply with all national, state, and local codes.**

The information in this manual is offered only as a guide to finalizing your installation plans.

NOTICE

For full service switching of the entire load, the ATS must be 'SE' (Service Entrance) rated or must have a properly rated fusible disconnect installed before the ATS to protect the contacts.

ENGINE GENERATOR SET MOUNTING

The unit's main frame must be bolted solidly to a solid base. The engine-generator is mounted on a channels which are attached with special shock mounts to the main frame. This allows the engine-generator free movement without affecting the base or surrounding equipment

The unit should be mounted to allow for ample working room around it. A general rule to follow is five (5) feet of clearance from an flammable surface (NFPA 37 code). These distances may be reduced for nonflammable surfaces but sufficient access should be provided for servicing the equipment.

VENTILATION REQUIREMENTS

Providing proper air movement during your installation planning is absolutely essential, You will need to provide fresh a air inlet as well as a hot air outlet for proper engine performance. These engine generator set are equipped with unit mount radiators and the engine is equipped with a pusher type fan. The hot air from the face of the radiator must be ducted out of the enclose to insure proper cooling. Failing to do so will allow the hot air to recirculate around the radiator causing the engine to overheat resulting in an engine shutdown. If louvers are used in front of the hot air duct to protect the unit from outside weather, these louvers should be 1 1/2 time as large as the area of the radiator face to prevent pack pressure.

In addition to a hot air discharge you must plan for a fresh air intake opposite the radiator discharge. These fresh air inlets should also be 1 1/2 to 2 times large that the radiator face. The extra air inlet area is required to minimize restriction and to provide combustion air for the engine. Installing them opposite the hot air discharge, this will allow a sweeping flow of cooling air across the engine preventing hot spots.

FUEL INSTALLATION

The fuel supply should be as close to the engine as possible. This will reduce the installation cost of fuel runs and minimize line losses. The diesel fuel supply should be no more than 3 feet below the fuel inlet on the pump. If your fuel supply is lower than three feet you may have to install an additional lift pump to bring the fuel up to the mechanical fuel pump on the engine.

The information in this manual is offered to assist you in providing the proper fuel for your engine. However, this information is only provided to inform you of the engine's requirements and assist in making you aware of the decisions you must make. In no case should the instructions or information provided be interpreted to conflict with any local, state or national codes. If in doubt, always consult your local fire marshal or fuel supplier.

INSTALLING THE FUEL LINE

Engine generator sets are properly adjusted before they leave the factory. Connecting a fuel supply with adequate supply volume is critical to reliable operation. Diesel units with optional base mounted fuel tanks are pre-plumbed to the mechanical fuel pump on the engine.

Open skid mounted Diesel units are often supplied with capped inlet and return lines. The use of a suitable customer supplied flexible fuel line is essential between the engine and fuel supply to provide a vibration break between your fuel supply and the engine.

**** **WARNING** ****

FIRE DANGER - Connecting rigid fuel line (i.e. steel or copper line) directly to the inlet fuel filter or fuel pump may cause the fuel line to crack during operation creating a serious fire hazard.

DE45 & DE65 FUEL LINE CONNECTIONS



FUEL INLET CONNECTION

FUEL RETURN LINE CONNECTION

FUEL CONNECTION FOR DE30



FUEL INLET CONNECTION FUEL RETURN LINE CONNECTION

FUEL CONNECTION FOR DE20



FUEL INLET CONNECTION



FUEL RETURN LINE CONNECTION

LUBRICATION

Before starting the engine, check the oil level in the crankcase. If it is low, refill to the full mark with the proper weight/grade of oil as recommended by the engine manufacturer's maintenance instructions. The necessity of using the correct oil, and keeping the crankcase full cannot be over emphasized. Failure to use the proper oil and keep the crankcase properly filled will cause excessive engine wear and shorten its useful life.

COOLANT

Before starting the engine, check the coolant level in the radiator. If it is low, refill as specified in the engine manufacturer's maintenance instructions. The radiator should be filled to about 1 inch below the filler neck. For additional information on engine coolant requirements see engine manufacturer's maintenance instructions.

INSTALLING THE BATTERY

**** CAUTION ****

In the following battery installation procedure, check to be sure the engine control is in the "stop" position. This should be your last step before initial start-up.

A customer supplied twelve-volt battery is required to complete the installation. Installation of the highest CCA rated battery, within the correct BCI group, will increase cold weather starting performance. *Gel batteries should not be used with the battery tender installed in the generator enclosure.*

BATTERY REQUIREMENTS

<u>Model</u>	<u>Voltage</u>	<u>BCI Group</u>	<u>MINIMUM CCA Rating</u>
DR20I	12	24	650
DE30I	12	24	650
DE45I	12	24	650
DE65I	12	24	650

**** WARNING ****

EQUIPMENT DAMAGE- All of these units are 12 Volt and they are all negative ground. Permanent damage will occur if they are connected to a 24 volt system or a positive ground system. If you are using the truck batteries to start these units you may have to disable the charging system to keep it from interfering with the vehicle charging system.

Installation and servicing of batteries must be performed or supervised only by personnel knowledgeable of batteries and the required precautions. Keep unauthorized personnel away from batteries.

When installing or replacing batteries, use the proper group/size **starting** battery. The battery should be a Maintenance Free lead acid design. Deep cycle batteries will not work for this application.

CAUTION – PERSONAL DANGER

CAUTION - NEVER dispose of a battery in a fire. The battery is capable of exploding.

CAUTION -DO NOT open or mutilate the battery. Released electrolyte is known to be harmful to the skin and eyes and to be very toxic.

These engine generator sets are all **NEGATIVE** ground. Be very careful not to connect the battery in reverse polarity, as this may short circuit the battery charging system on the engine.

CAUTION – A battery presents a risk of electrical shock and high short circuit current. The following precautions must be observed when working with batteries:

1. Remove watches, rings and other metal objects.
2. Use tools with insulated handles.
3. Check both the battery cable ends and the battery posts to be sure they are free of corrosion.
4. Always connect the battery positive cable first and then

connect the battery negative cable. When removing the battery cables from the battery reverse the procedure, disconnect the negative cable first and then the positive cable.

5. Be sure all connections are tight and coat the terminals and cable ends with dielectric grease.

WARNING – The electrolyte is a diluted sulfuric acid that is harmful to the skin and eyes. It is electrically conductive and corrosive. The following precautions must always be taken:

- * Always wear full eye protection and protective clothing
- * Where electrolyte contacts the skin, wash off immediately with water
- * If electrolyte contacts the eyes, flush thoroughly and immediately with water and seek immediate medical attention
- * Spilled electrolyte is to be washed down with an acid neutralizing agent. A common practice is to use a solution of one pound of bicarbonate of soda (baking soda) to one gallon of water. The bicarbonate of soda solution is to be added until the evidence of reaction, foaming, has ceased. The resulting liquid is to be flushed with water and the area dried.

DANGER – Explosive Fire Risk

- * Never smoke when near batteries
- * Do not cause a flame or spark in the battery area
- * Always discharge static electricity from your body before touching batteries by first touching a grounded metal surface

SERVICING BATTERIES

Batteries used on these units may, over time, lose water. This is especially true if you are using a trickle charger to maintain your battery. When refilling the battery with water use only distilled water. Tap water will shorten the service life of the battery.

Never fill the battery above the fill line. Over filling above the upper level line may cause the electrolyte to overflow, resulting in corrosion to the engine or nearby parts. Immediately wash off any spilled electrolyte following the procedure above.

NOTE: Always make sure that a new battery is fully charged before installing it on a generator set. Failure to do so can cause damage to the engine control module in the generator set.

All connections must be clean and tight. Check the electrolyte (fluid) in the battery periodically to be sure it is above the plates. Never allow the battery to remain in a discharged condition.

A.C. ELECTRICAL CONNECTIONS

NOTICE - CLASS 1 WIRING METHODS ARE TO BE USED FOR ALL FIELD WIRING CONNECTIONS TO TERMINALS OF A CLASS 2 CIRCUIT

Note: This symbol  always indicates ground where shown.

All wiring must be completed in accordance with the Nation Electric Code as well as any state or local codes.

You must pay particular attention to wire size requirement for the amperage of service you are dealing with. The table below provides you guidance on wire sizing based on both wire type and amperage. **Wire amperage's have been derated for 40° C ambient temperatures operation. See page 8 for wiring schematic.**

****** WARNING ******

A main line circuit breaker has been provided inside the generator housing. During all wiring installations make sure the breaker is in the OFF position and the generator operation switch is in the OFF position.

Neutral Lugs, DE20 has 100 amp neutral lugs are isolated from ground and provided for you to connect your neutral wire to from the transfer switch or load distribution center. The lugs will accommodate #12 AWG to #1/0 Awg and should be torqued to 50 in. lbs. The DR30 and larger have 225 AMP neutral lugs and will accommodate #4 AWG to 300 MCM and should be torqued to 250 in. lbs. The exception is the DE65 single phase unit which has a 400 amp neutral block. The 400 amp terminal block lugs will handle wire sizes #1 AWG to 400 MCM and should be torqued to 300 in. lbs.

Generator Circuit Breaker, This circuit breaker provides overload protection for the generator. Your power feeds from the load panel will connect to the open lugs on the circuit breaker. The generator power feeds have already been wired into one set of lugs.

The table below gives you the circuit breaker size, lug wire sizes and torque specification. (see the actual breaker for additional information and restrictions)

kW	Voltage	PH	Amp	Wire Capability	Lug Torque
20	120/240	1	85	#12 AWG -2/0 AWG	50 in lbs
20	120/208	3	70	#12 AWG -2/0 AWG	50 in lbs
20	120/240	3	60	#12 AWG -2/0 AWG	50 in lbs
20	277/480	3	30	#14 - #1/0 AWG	80 in lbs

kW	Voltage	PH	Amp	Wire Capability	Lug Torque
30	120/240	1	125	#12 AWG -2/0 AWG	50 in lbs
30	120/208	3	100	#12 AWG -2/0 AWG	50 in lbs
30	120/240	3	90	#12 AWG -2/0 AWG	50 in lbs
30	277/480	3	45	#14 - #1/0 AWG	80 in lbs

kW	Voltage	PH	Amp	Wire Capability	Lug Torque
45	120/240	1	175	#4 AWG - 300 MCM	250 in lbs
45	120/208	3	150	#4 AWG - 300 MCM	250 in lbs
45	120/240	3	125	#4 AWG - 300 MCM	250 in lbs
45	277/480	3	60	#14 - #1/0 AWG	80 in lbs

kW	Voltage	PH	Amp	Wire Capability	Lug Torque
65	120/240	1	250	#1 AWG - 600 MCM	375 in lbs
65	120/208	3	225	#4 AWG - 300 MCM	250 in lbs
65	120/240	3	200	#4 AWG - 300 MCM	250 in lbs
65	277/480	3	100	#14 - #3/0 AWG	120 in lbs

CONTROL BOX AC WIRING

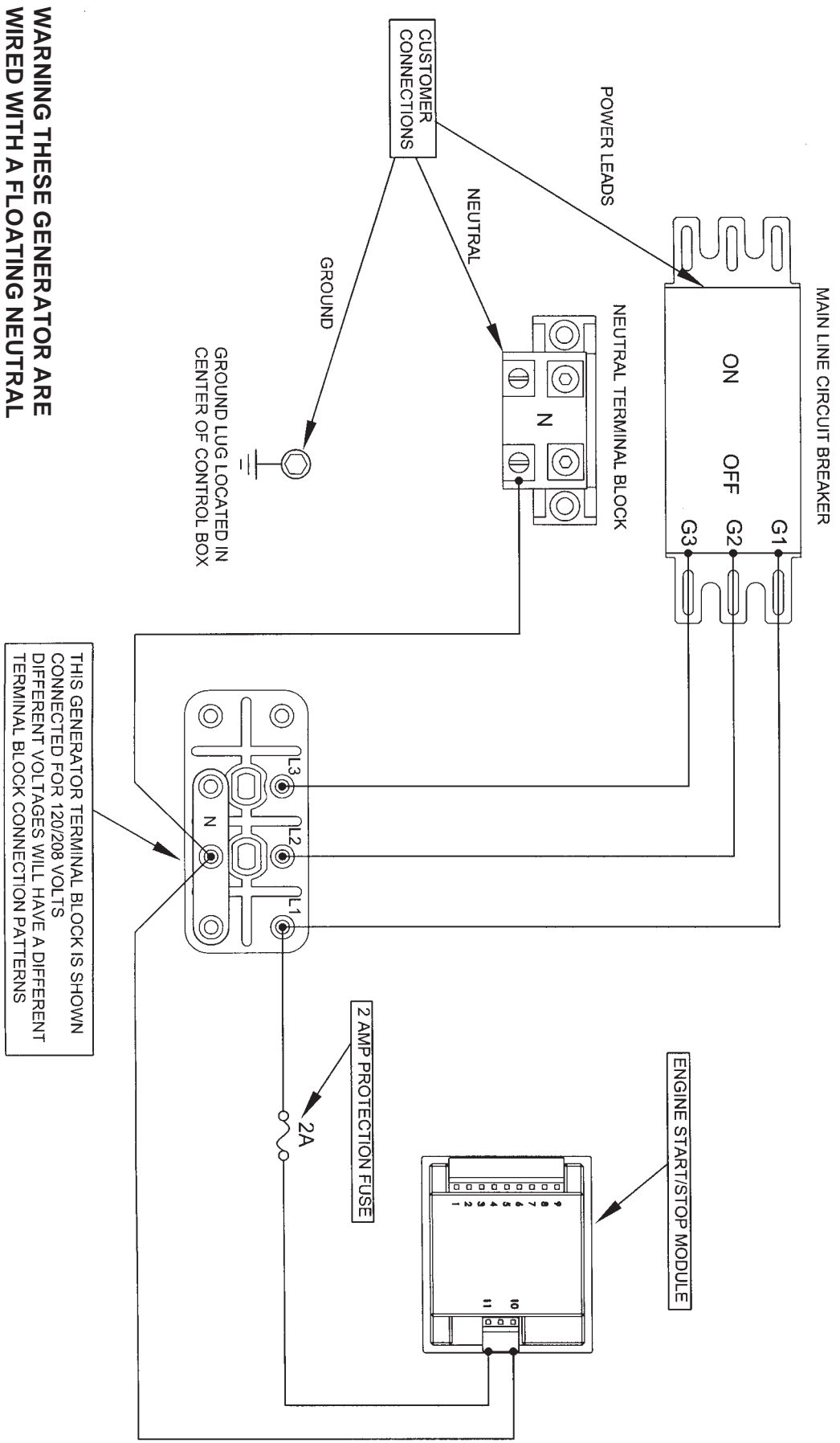

WARNING THESE GENERATOR ARE WIRED WITH A FLOATING NEUTRAL

THIS GENERATOR TERMINAL BLOCK IS SHOWN CONNECTED FOR 120/208 VOLTS DIFFERENT VOLTAGES WILL HAVE A DIFFERENT TERMINAL BLOCK CONNECTION PATTERNS

Minimum Conductor Sizes between the Generator and the load. Based on wire type and temperature rating. Wire has been derated for 40° C ambient temperatures.

kW	Voltage	PH	C/B Amp	Cu Conductor		Al Conductor	
				Wire Temperature Rating			
				75°C	90°C	75°C	90°C
20	120/240	1	85	#3 AWG	#4 AWG	#1 AWG	#2 AWG
20	120/208	3	70	#4 AWG	#6 AWG	#3 AWG	#4 AWG
20	120/240	3	60	#4 AWG	#6 AWG	#3 AWG	#4 AWG
20	277/480	3	30	#8 AWG	#8 AWG	#8 AWG	#8 AWG
30	120/240	1	125	1/0 AWG	#1 AWG	3/0 AWG	2/0 AWG
30	120/208	3	100	#2 AWG	#3 AWG	1/0 AWG	#1 AWG
30	120/240	3	90	#2 AWG	#3 AWG	1/0 AWG	#2 AWG
30	277/480	3	45	#6 AWG	#8 AWG	#4 AWG	#6 AWG
45	120/240	1	175	3/0 AWG	2/0 AWG	250 MCM	4/0 AWG
45	120/208	3	150	2/0 AWG	1/0 AWG	3/0 AWG	2/0 AWG
45	120/240	3	125	1/0 AWG	#1 AWG	3/0 AWG	2/0 AWG
45	277/480	3	60	#4 AWG	#6 AWG	#3 AWG	#4 AWG
65	120/240	1	250	300 MCM	250 MCM	500 MCM	350 MCM
65	120/208	3	225	250 MCM	4/0 AWG	400 MCM	300 MCM
65	120/240	3	200	4/0 AWG	3/0 AWG	300 MCM	250 MCM
65	277/480	3	100	#2 AWG	#3 AWG	1/0 AWG	#1 AWG

For additional information on wire sizing refer to table 310-16 of the National Electrical Code ANSI/NFPA 70..

For additional information on wire sizing refer to table 310-16 of the National Electrical Code ANSI/NFPA 70.

Ground Lug, These ground lugs are bonded to ground and are provided for you to connect your ground wire from the transfer switch to. The lugs on the 65 kW will handle wire sizes #6 AWG to 300 MCM and should be torqued to 250 in. lbs. The lugs on the 20 through 45 kW will accommodate #10 AWG to 2/0 AWG and should be torqued to 200 in. lbs.

 ***** **WARNING** *****

PERSONAL DANGER - These unit are shipped with a FLOATING NEUTRAL. If you not connecting to an existing power system you must install a neutral to ground bond in the generator connection box. I your system already has a neutral to ground bond then you must run a separate ground lead to that location. For additional questions refer to the current National Electric Code on grounding.

 ***** **WARNING** *****

EQUIPMENT DAMAGE - When installing a Three Phase 240 volt system be sure you know which lead is the high voltage "wild" leg (208 Volt line to neutral). The generator normally carries the high voltage on the G2 lead.

All wires should be installed in flexible conduit. (Knockout covered with a rubber plug is provided in the control box).



A B C D

ENGINE CONTROL PANEL LAYOUT

A - 2 AMP FUSE This fuse supplies the DSE702 controller 120 Volt AC. This tells the controller that the unit is running. (Replacement AGC-2A-250V)

B - 2 AMP FUSE -This fuse is in the 12 volt DC power supply for the DSE702 controller circuitry on the board. It also supplies the voltage for the two or three control relay in the control cabinet. (Replacement AGC-2A-250V)

C - 25 AMP FUSE- This fuse provides the 12 volt DC voltage for the relay controlling the starting, fuel, and glow plugs. (Replacement AGC-25A-250V)

D - DSE702 Start Controller - See Description Later

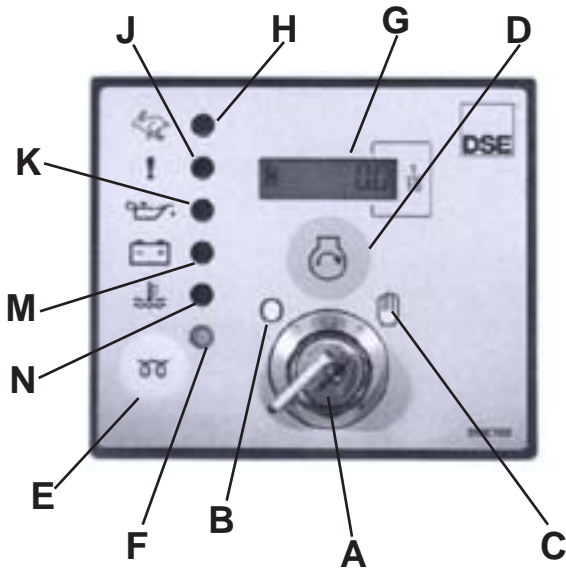

DSE702 CONTROL

A - KEY SWITCH -Turns the controller on and off.

B - STOP/RESET - With key in this position the unit is shut off. This position also resets the controller if it has gone into fault.

C - RUN POSITION - The key in this position will allow the glow plugs to be turned on and the unit to be started.

D - START BUTTON - When this button is depressed the starter is engaged and will stay engaged until the button is released.

E - GLOW PLUG SWITCH - When this button is depressed the glow plug circuit is activated, operating the glow plugs on the engine. When it is released the glow plug circuit is disconnected.

F - GLOW PLUG INDICATOR LED - When the glow plug switch is depressed this LED will light up indicating the circuit has been activated.

G - RUNNING TIME METER - This digital display will track the hours of operation of the engine generator set. This meter only runs any time the key is in the run position.

H - OVERSPEED/UNDERSPEED LED - Overspeed: This light will illuminate if the engine speed exceeds the preset trip point (14% above nominal frequency or about 68 Hz) and a shutdown is initiated. The overspeed is not delayed, it is an immediate shutdown. Underspeed: This light will flash if the engine speed falls below 20Hz after the **Safety On*** time has expired and a shutdown is initiated.

J - FAIL TO START - Not used on the manual start controller.

K - LOW OIL PRESSURE - This light will illuminate if the module detects that the engine oil pressure has fallen below the oil pressure switch setting (15 psi) after the **Safety On*** time has expired and a shutdown is initiated.

M - BATTERY CHARGE FAILURE - Not used in this application.

N - HIGH WATER TEMPERATURE - This light will illuminate if the module detects that the engine coolant temperature has exceeded the limit the coolant temperature switch after the **Safety On*** timer has expired and a shutdown is initiated.

NOTE: All warnings are reset but turning the key to off position.

* **SAFETY ON TIMER** - The safety on delay on this controller is 10 seconds. Should a fault condition still be detected after this 10 second delay the engine will shutdown and fault code will be illuminated.

INITIAL START UP

 **** **WARNING** ****

EQUIPMENT DAMAGE - DO NOT jump start these engine generator sets. Starting these units on a low battery or jump starting them will cause damage to the engine control module.

Use the following check list to verify correct installation before starting the engine:

1. Engine oil. Fill as required with proper grade/qty.
2. Engine coolant. Fill as required with proper mixture.
3. Unit mounting base properly bolted down.
4. Clearance for service and maintenance on all sides.
5. Proper fuel line material and size.
6. All fuel line connections tight.
7. Battery connections clean and tight.
8. Battery fully charged.
9. All AC and DC wiring installed and properly protected.

After completing the above checklist, the engine-generator set is ready for the initial start-up test.

STARTING PROCEDURE

MANUAL MODE

 **** **WARNING** ****

EQUIPMENT DAMAGE - BEFORE ATTEMPTING TO START THIS UNIT COMPLETE YOUR PRE-START CHECKLIST AND INSURE THE GENERATOR MAINLINE CIRCUIT BREAKER IS IN THE PROPER POSITION PRIOR TO STARTING. STARTING THIS UNIT WITHOUT IT PROPERLY CONNECTED CAN CAUSE SERIOUS PERSONAL INJURY OR EQUIPMENT DAMAGE.

1. Rotate the key (A) to the run position (C).
2. If your unit is equipped with glow plugs depress the glow plug button (E) for about 10 seconds.

3. Depress the start button (D) to engage the start circuit. The starter should engage and the unit will start. Once the unit has started release the start button to disengage the starter.
4. If the start button is release before the engine starts or the unit does not stay running the key switch (A) has to be turn to the off position and back to the run position before the starter can be reengage using the start button (D). This protects the starter from accidently being engage with the unit running.
5. Once the unit is running and the safety on time has elapsed the engine monitoring switches are active.
6. If the unit should shut down and display a fault light (H,K or N) clear the fault before attempting to restart the unit.
7. After the engine is up an running the circuit breaker can be closed to power you loads. During period of very cold operation it is best to let the engine warm up for a few seconds before applying the load.
8. When stopping the unit it is best to turn off all the loads before turning the key switch to the off (B) position. This prevents your loads from getting low voltage will still running during unit shutdown.

ENGINE WILL NOT COME UP TO SPEED AFTER IT STARTS

1. Insufficient fuel volume getting to the unit.
 - a. Too small of fuel line.
 - b. Fuel racks not opened properly.
2. Governor is defective.
3. AC short in generator components.

NO AC OUTPUT FROM GENERATOR

1. Defective diode.
2. Defective voltage regulator.
3. Defective rotor.
4. Defective stator.
5. Defective exciter rotor.
6. Defective exciter stator.
7. AC short in the output leads.
8. Defective/open generator output breaker.
9. Wiring error.

TROUBLESHOOTING TABLES

ENGINE WILL NOT CRANK WITH GENERATOR RUN PUSH-BUTTON DEPRESSED.

1. Low/dead battery.
2. Blown DC fuses 2 amp or 25 amp.
3. Defective DSE702.
4. Loose or dirty battery terminals.
5. Defective starter.
6. Defective start solenoid.
7. Locked up engine genset.

ENGINE CRANKS BUT WILL NOT START

1. Improper fuel delivery to the unit.
2. Fuel supply shut off.
3. Fuel tank empty.
4. Air in the fuel system.
5. Engine fuel solenoid has not opened.
6. Defect fuel pump.

ENGINE STARTS AND THEN STOPS AND ALARM LIGHT COMES ON

1. Engine oil pressure is low.
2. Engine has high water temperature.
3. Engine has overspeed.

DE 20 OUTLINE DRAWING

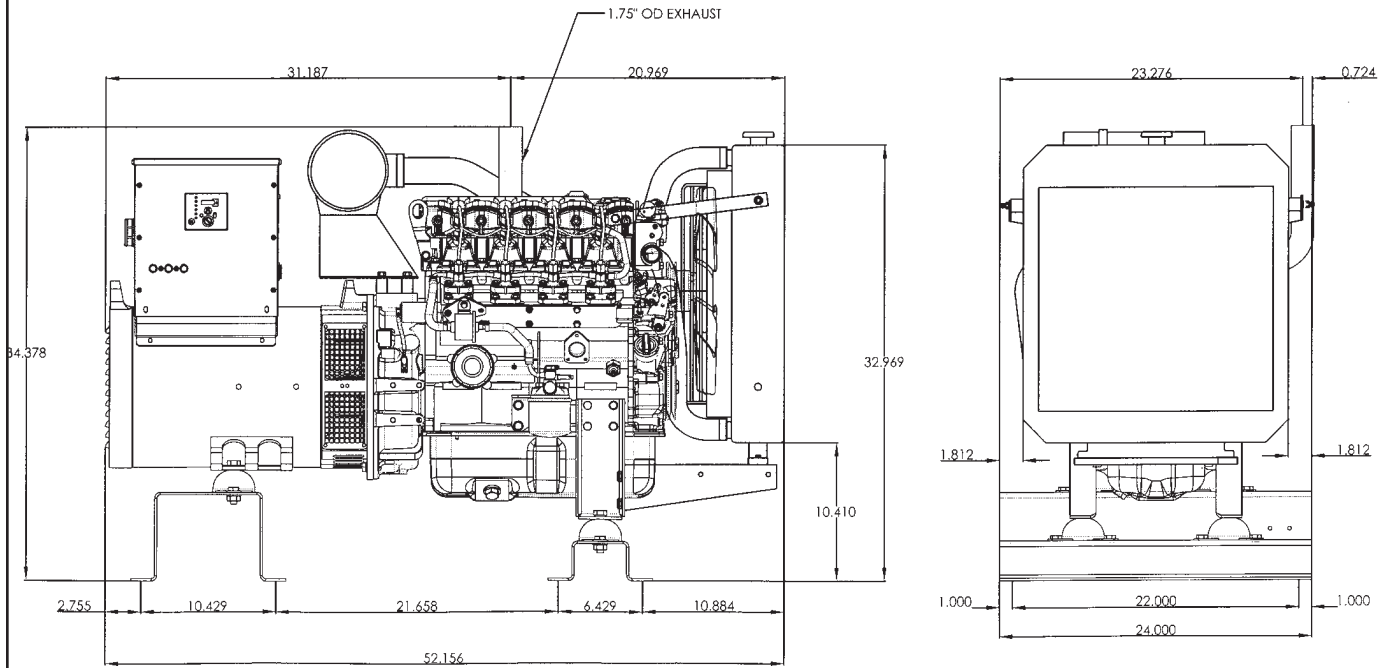

DE30 OUTLINE DRAWING

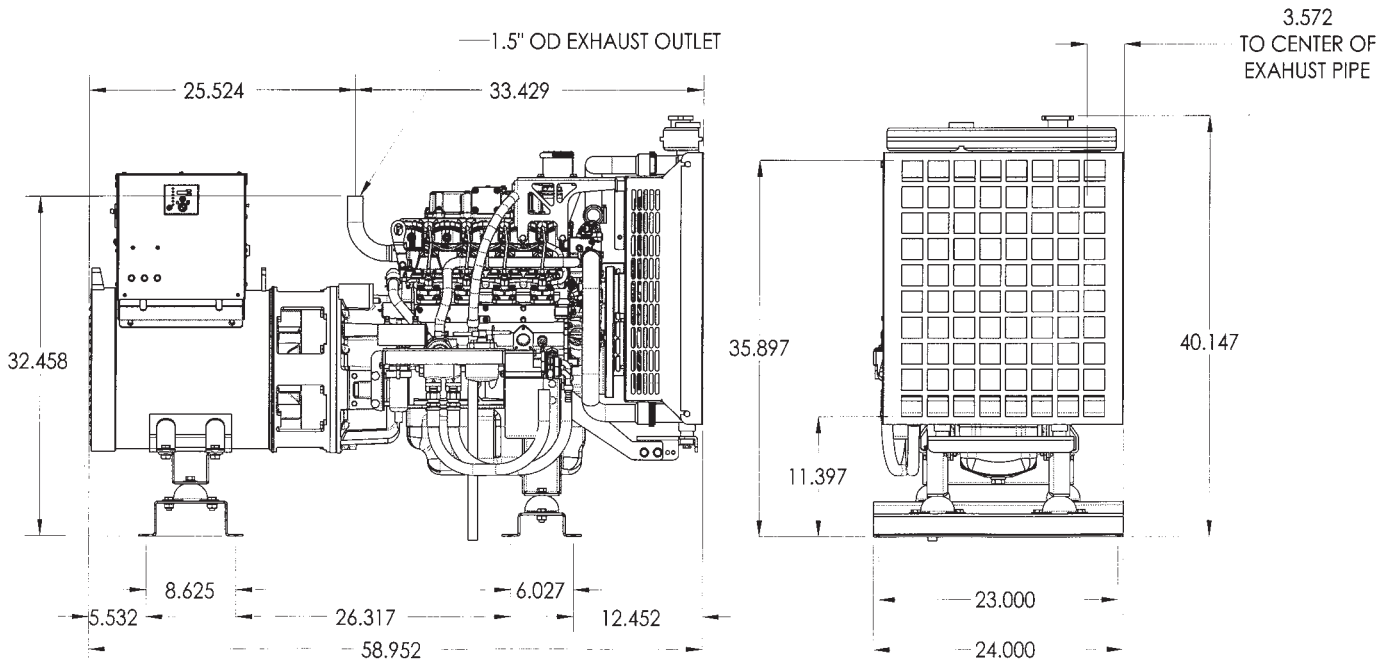

DE45 & DE65 OUTLINE DRAWING

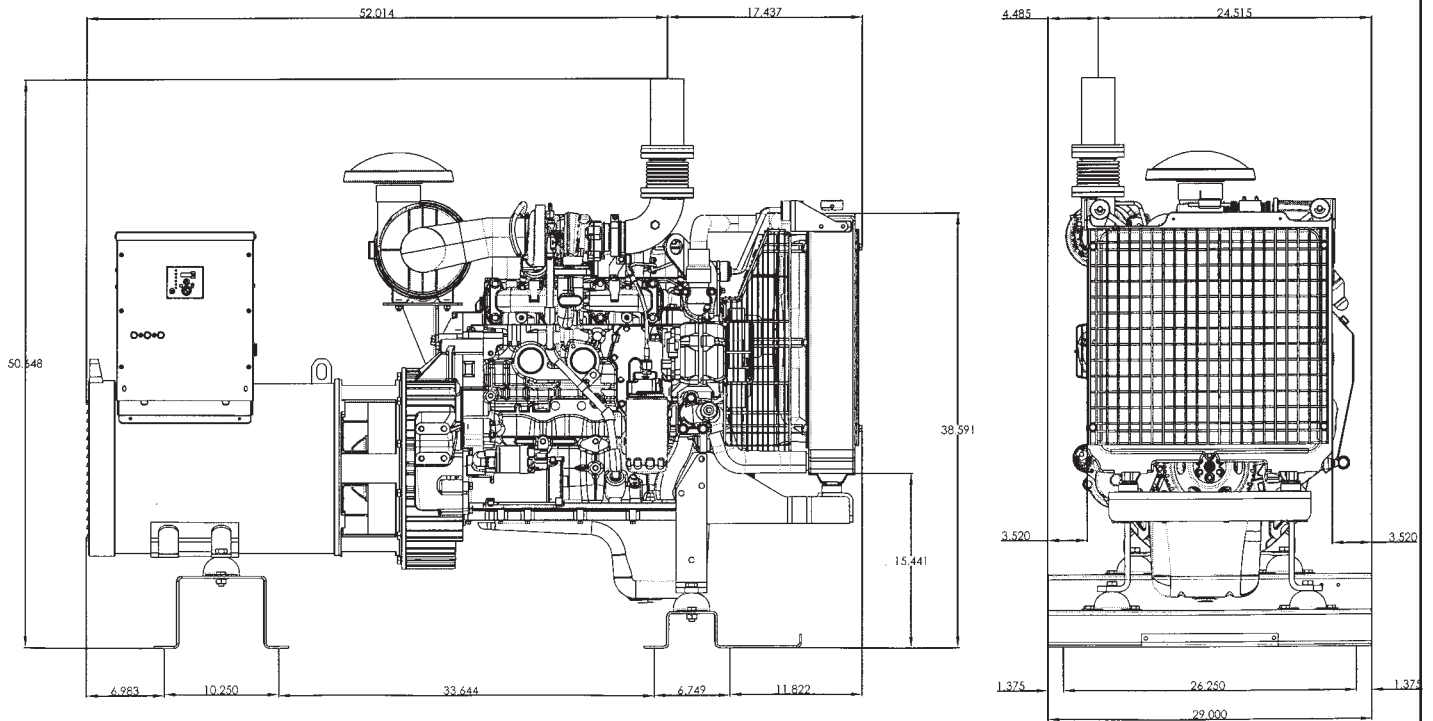

DE45 & DE65 DC SCHEMATIC

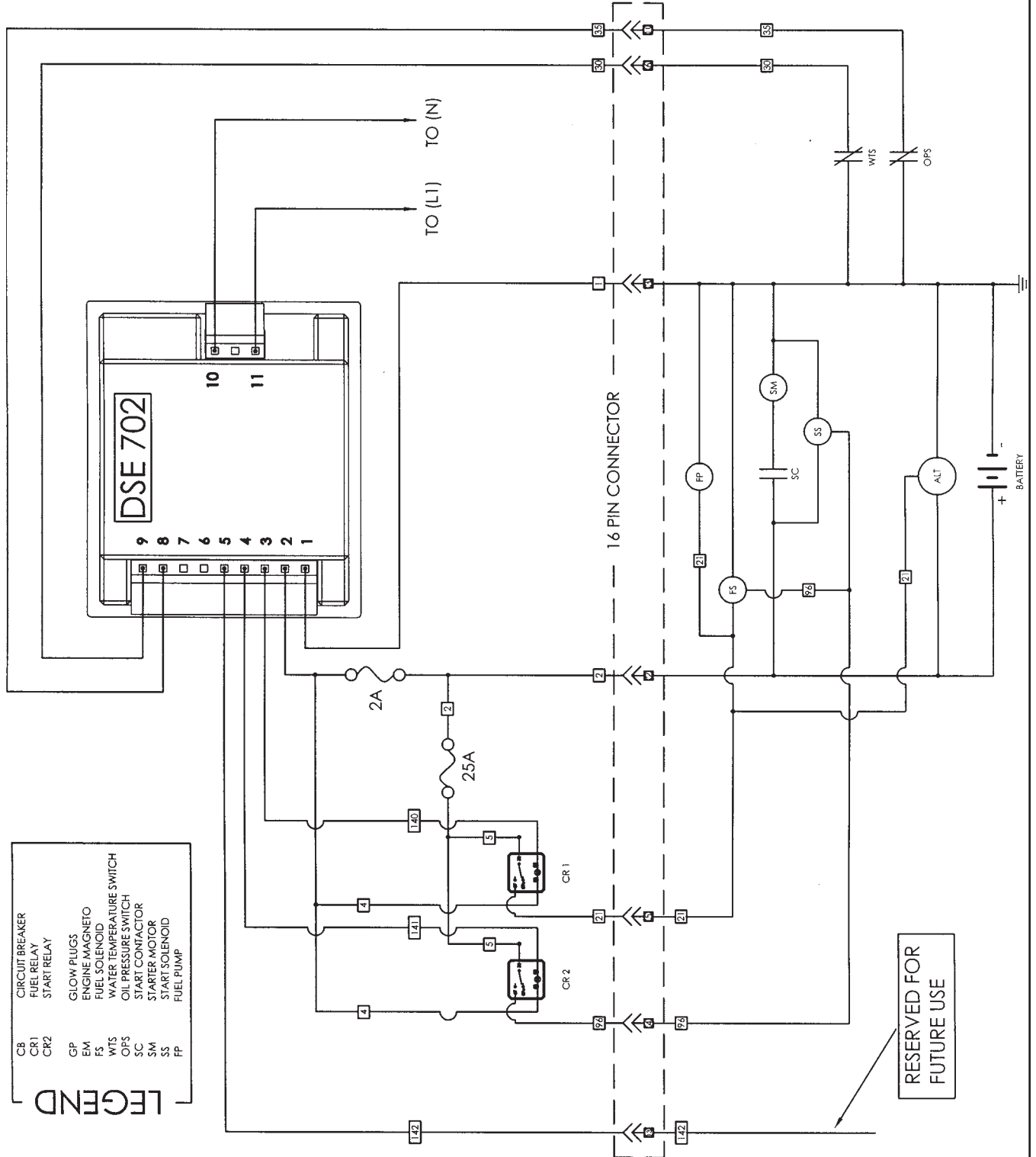

LEGEND

CB	CIRCUIT BREAKER
CR1	FUEL RELAY
CR2	START RELAY
GP	GLOW PLUGS
EM	ENGINE MAGNETO
FS	FUEL SOLENOID
WTS	WATER TEMPERATURE SWITCH
OPS	OIL PRESSURE SWITCH
SC	START CONTACTOR
SM	START MOTOR
SS	START SOLENOID
FP	FUEL PUMP

THREE PHASE AC WIRING HIGH AND LOW WYE

**THREE PHASE-HIGH WYE
277/480 VOLTS**

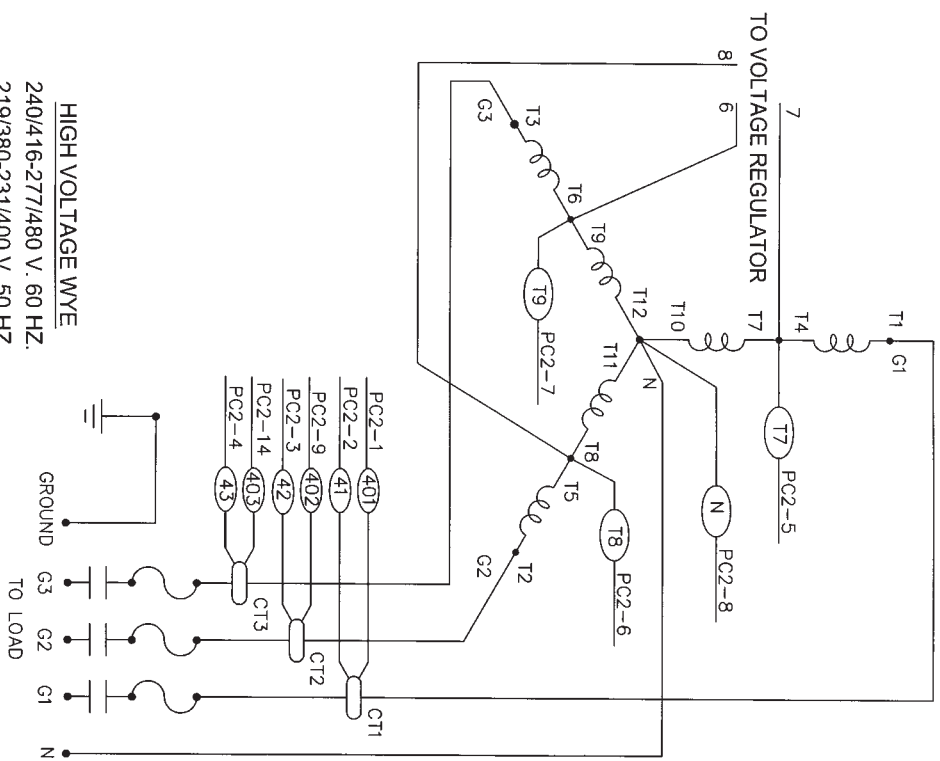

HIGH VOLTAGE WYE
240/416-277/480 V. 60 HZ.
219/380-231/400 V. 50 HZ.

**THREE PHASE-LOW WYE
120/208 VOLTS**

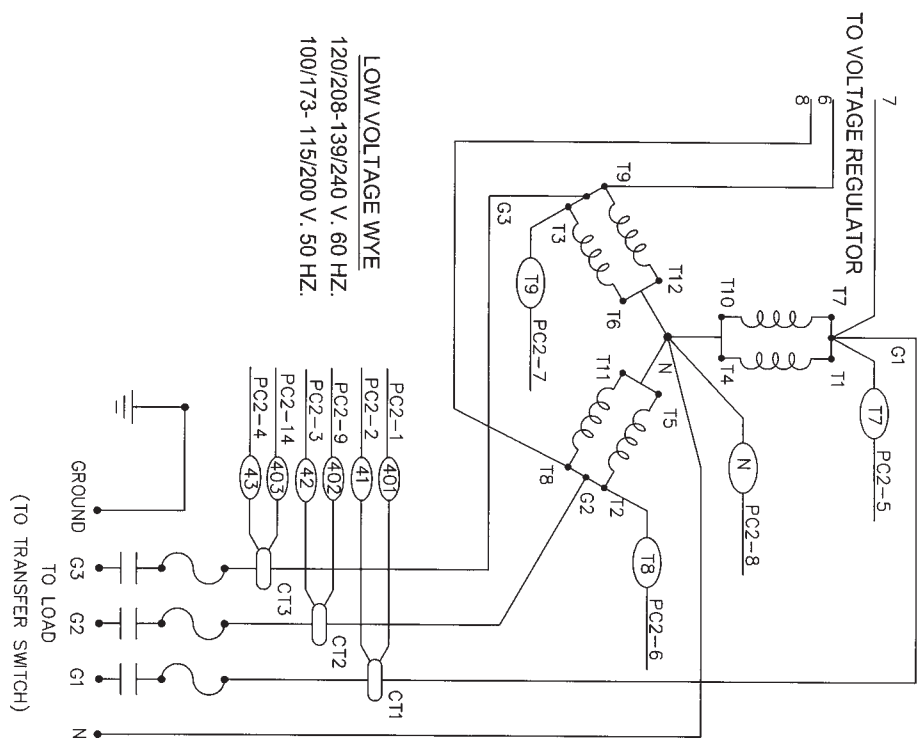

LOW VOLTAGE WYE
120/208-139/240 V. 60 HZ.
100/173- 115/200 V. 50 HZ.

THREE PHASE AC WIRING - DELTA

SINGLE PHASE AC WIRING

SINGLE PHASE 120/240 VOLTS

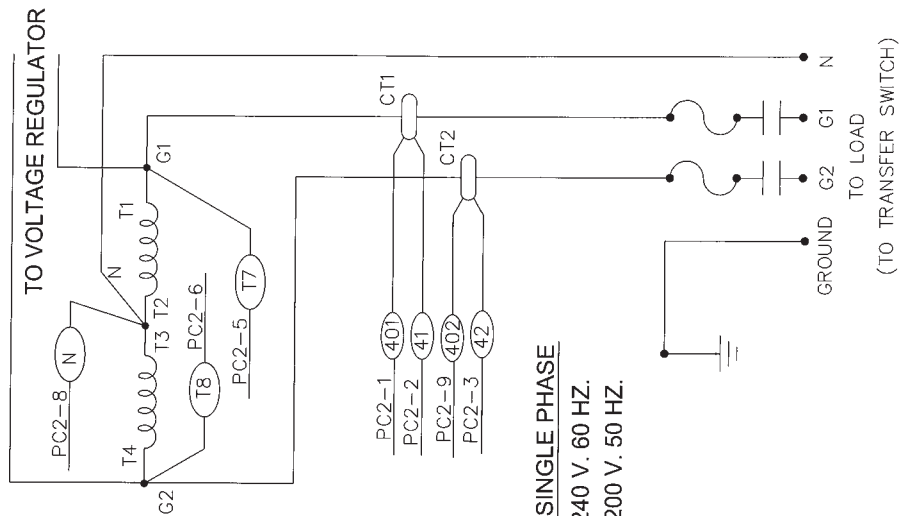

HIGH VOLTAGE SINGLE PHASE

120/208-139/240 V. 60 HZ.
100/173- 115/200 V. 50 HZ.

THREE PHASE -DELTA 120/240 VOLTS

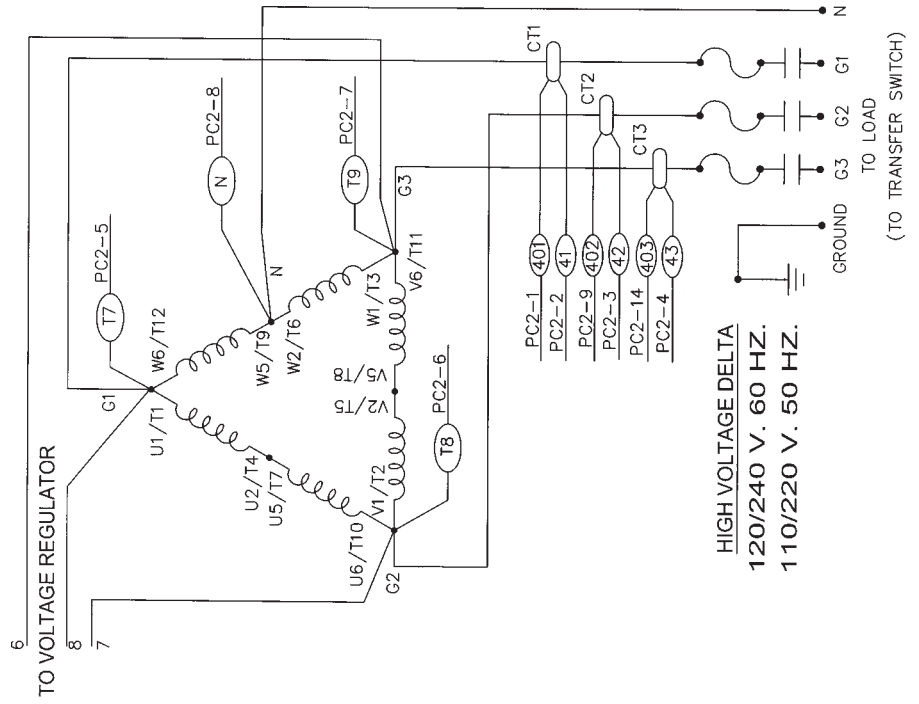

HIGH VOLTAGE DELTA

120/240 V. 60 HZ.
110/220 V. 50 HZ.



Limited Warranty

WINPOWER, Incorporated warrants to the original purchaser for 12 months or 1000 hours which ever occurs first, that goods manufactured or supplied by it will be free from defects in workmanship and material, provided such goods are installed, operated and maintained in accordance with WINPOWER written instructions.

WINPOWER's sole liability, and Purchaser's sole remedy for a failure under this warranty, shall be limited to the repair of the product. At WINPOWER's option, material found to be defective in material or workmanship under normal use and service will be repaired or replaced. For warranty service, return the product within 12 months or 1000 hours which ever occurs first from the date of purchase, transportation charges prepaid, to your nearest WINPOWER Authorized Service Center or to WINPOWER, Inc. at Le Center Minnesota.

THERE IS NO OTHER EXPRESS WARRANTY.

To the extent permitted by law, any and all warranties, including those of merchantability and fitness for a particular purpose, are limited to 12 months or 1000 hours which ever occurs first, from date of purchase. In no event is WINPOWER liable for incidental or consequential damages.

Note: Some states do not allow limitation on the duration of implied warranty and some states do not allow the exclusion or limitation of incidental or consequential damages, so the above limitations may not apply in every instance. This warranty gives you specific legal rights which may vary from state to state.

WINPOWER reserves the right to change or improve its products without incurring any obligations to make such changes or improvement on products purchased previously.

EXCLUSIONS:

WINPOWER does not warrant Engines. Engines are covered exclusively by the warranties of their respective manufacturers, see enclosed warranties.

WINPOWER does not warrant Batteries, or Other Component Parts that are warranted by their respective manufacturers.

WINPOWER does not warrant modifications or alterations which were not made by WINPOWER, Inc.

WINPOWER does not warrant products which have been subjected to misuse and/or negligence or have been involved in an accident.

WINPOWER
A Division of  Dyna Technology Inc
225 S. Cordova
Le Center MN 56057
Phone - 507-357-6707
www.winpowerinc.com