

WINPOWER

*A Division of **DTT** Dyna Technology Inc*

DIESEL GENERATOR

INSTALLATION AND OPERATIONS MANUAL

DR2014-A

DR2014-D

DR2014-J

DR2014-L

DR2014-X

SAVE THESE INSTRUCTIONS

This manual contains important instructions that should be followed during installation and maintenance of the generator and batteries.

Read and understand all instructions in the manual before starting and operating the generator set.

USING THIS MANUAL

Congratulations on your choice of a Winpower generator set. You have selected a high-quality, precision-engineered generator set designed and tested to give you years of satisfactory standby service.

To get the best performance from your new engine generator set, it is important that you carefully read and follow the operating instructions in this manual.

Should you experience a problem please follow the "Things To Check" near the end of this manual. The warranty listed in this manual describes what you can expect from WINPOWER should you need service assistance in the future.

COPY YOUR MODEL AND SERIAL NUMBER HERE

No other WINPOWER generator has the same serial number as yours. It is important that you record the number and other vital information here. If you should ever need to contact us on this unit it will help us to respond to your needs faster.

MODEL _____

SERIAL NUMBER _____

'M" Spec. _____

PURCHASE DATE _____

DEALER _____

TABLE OF CONTENTS

INTRODUCTION	i
GUIDE TO PRODUCT SAFETY	1
BASIC INFORMATION	2
Specification Table	2
Description	2
DSE-7310 Description	3
RECEIVING THE GENERATOR	3
Unpacking the unit	4
ENGINE GENERATOR INSTALLATION	
Installation	5
Engine Generator Set Mounting	5
Fuel Installation	5
Lubrication	6
Coolant	6
Battery Installation	6
Battery Charger/Block Heater Wiring	7
Mounting The Transfer Switch	7
AC Electrical Connections	7
DC Electrical Connections	8
DSE 7310 Engine Control Layout	10
DSE 7310 Operations	10
INITIAL START-UP	11
EXERCISER CLOCK	12
TROUBLESHOOTING INFORMATION	12
DC SCHEMATIC - WIRING DIAGRAM	13
AC WIRING - THREE PHASE	
277/480 Volt	14
120/208 Volt	14
120/240 Volt	15
AC WIRING - SINGLE PHASE	
120/240 Volt	15
ENGINE WIRING HARNESS	16
SUPPLEMENT INSTRUCTIONS FOR SWITCHABLE VOLTAGE UNITS	17
DC SCHEMATIC - WIRING DIAGRAM	18
GENERATOR WIRING	19
VOLTAGE SELECTOR SWITCH WIRING	20
CIRCUIT BREAKER WIRING	21
12 MONTH WARRANTY	22

PROPER USE AND INSTALLATION

You must be sure your new engine generator set is:

- * Properly serviced before starting
- * Operated in a well ventilated area
- * Properly exhausted and gases safely dispersed
- * Wired by a qualified electrician
- * Operated only for its designed purposes
- * Used only by operators who understand its operation
- * Properly maintained

IMPORTANT SAFETY INSTRUCTIONS

SAVE THESE INSTRUCTIONS

This manual contains important instructions that should be followed during installation and maintenance of the generator and batteries.

Read and understand all instructions in the manual before starting and operating the generator set.

This engine generator set has been designed and manufactured to allow safe, reliable performance. Poor maintenance, improper or careless use can result in potential deadly hazards; from electrical shock, exhaust gas asphyxiation, or fire. Please read all safety instructions carefully before installation or use. Keep these instructions handy for future reference. Take special note and follow all warnings on the unit labels and in the manuals.

ANSI SAFETY DEFINITIONS

DANGER:

DANGER indicates an imminently hazardous situation which, if not avoided, will result in death or serious injury. This signal word is to be limited to the most extreme situations.

WARNING:

WARNING indicates a potentially hazardous situation which, if not avoided, could result in death or serious injury.

CAUTION:

CAUTION indicates a potentially hazardous situation which, if not avoided, may result in minor or moderate injury. It may also be used to alert against unsafe practices.

NOTE:

CAUTION is also used on the unit labels and in this manual to indicate a situation that could result in serious damage or destruction of the equipment and possible personal injury.

1. **ELECTRIC SHOCK** - The output voltage present in this equipment can cause a fatal electric shock. This equipment must be operated by a responsible person.
 - a. Do not allow anyone to operate the generator without proper instruction.
 - b. Guard against electric shock.
 - c. Avoid contact with live terminals or receptacles.
 - d. Use extreme care if operating this unit in rain or snow.
 - e. Use only three-prong grounded receptacles and extension cords.
 - f. Be sure the unit is properly grounded to an external ground rod driven into the earth.

2. **FIRE HAZARD** - Diesel fuel presents a hazard of possible explosion and/or fire.
 - a. Do not smoke or use open flame near the generator set.
 - b. Keep a fire extinguisher nearby and know its proper use. Fire extinguishers rated ABC by NFPA are appropriate.
3. **DEADLY EXHAUST GAS** - Exhaust fumes from any diesel engine contain carbon monoxide, an invisible, odorless and deadly gas that must be mixed with fresh air.
 - a. Operate only in well ventilated areas.
 - b. Never operate indoors.
 - c. Never operate the unit in such a way as to allow exhaust gases to seep back into closed rooms (i.e. through windows, walls or floors).
4. **NOISE HAZARD** - Excessive noise is not only tiring, but continual exposure can lead to loss of hearing.
 - a. Use hearing protection equipment when working around this equipment for long periods of time.
 - b. Keep your neighbors in mind when permanently installing this equipment.
5. **CLEANLINESS** - Keep the generator and surrounding area clean.
 - a. Remove all grease, ice, snow or materials that create slippery conditions around the unit.
 - b. Remove any rags or other material that could create potential fire hazards.
 - c. Carefully wipe up any fuel or oil spills before starting the unit.
 - d. Never allow leaves or other flammable material to build up around the engine exhaust area.
6. **SERVICING EQUIPMENT** - All service, including the installation or replacement of service parts, **should be performed only by a qualified technician.**
 - a. Use only factory approved repair parts.
 - b. Do not work on this equipment when fatigued.
 - c. Never remove the protective guards, cover, or receptacle panels while the engine is running.
 - d. Use extreme caution when working on electrical components. High output voltages from this equipment can cause serious injury or death.
 - e. Always avoid hot mufflers, exhaust manifolds, and engine parts. They all can cause severe burns instantly.
 - f. Installing a generator set is not a "do-it-yourself" project. Consult a qualified, licensed electrician or contractor. The installation must comply with all national, state, and local codes.
 - g. Always make sure unit is disabled before placing your hands anywhere near the fan, belts, alternator or water hoses.

TESTING POLICY:

Before any generator is shipped from the factory, it is fully checked for performance. The generator is loaded to its full capacity, and the voltage, current, and frequency are carefully checked.

Rated output of the generators is based on engineering tests of typical units, and is subject to, and limited by, the temperature, altitude, fuel, and other conditions specified by the manufacturer of the applicable engines.

SPECIFICATIONS

MODEL	DR2014-A	DR2014-D	DR2014-J	DR2014-L
Generator				
Wattage	20000	20000	20000	20000
Volts	120/240	120/208	120/240	277/480
Phase	single	three	three	three
PF	1.0	.80	.80	.80
AMPs	83.0	69.5	60.2	30.1
Hertz	60	60	60	60

Engine

Model	Isuzu 4LE1
Fuel Capacity-	32 gallons
Starting System	12 Volt Auto Start
Muffler	Standard
Stop System	Auto/Emergency
Fuel Consumption (full Load)	1.8 Gal/hour

Owner Must Provide

Fuel	ASTM D-975 - 1D or 2D EN590 or equivalent See engine manual for additional fuel types & specification
Oil Type	10W-30 CC/CD
See engine manual for additional oil information.	
Oil Capacity	8.6 Quarts
Cooling System	50/50 Mix

INTRODUCTION AND DESCRIPTION

PRODUCT DESCRIPTION:

This engine-generator set is designed for unattended remote start operation. It can be operated as part of a fully automatic standby power system or independently as a local start unit in a prime power system. The engine-generator set is fully tested at the factory prior to shipment to insure proper operation of each individual component as well as the total system's performance and reliability.

The engine generator set consists of a multi-cylinder, liquid cooled engine nominally operating at 1800 rpm. The generator frequency regulation is maintained by the engine governor to within +/- 1.5 hertz (cps), from no load to rated load for standard mechanical governors. The generator is a single bearing, direct drive, rotating field brushless design. The generator is connected to the engine flywheel via flexible drive disks. The Generator Set is skid mounted with isolation mounts between the engine and base on all units.

Unit Orientation Note: All references used in this manual for unit familiarization, access and component locations on the Generator Set are oriented from a TOP (plan) VIEW with engine at the FRONT and generator to the REAR.

A customer supplied 12 Volt battery is required to complete the installation. The battery should be a BCI group 24 battery with at least 650 CCA

The engine is controlled and generator set operation is monitored for safe operation by a programmable microprocessor based Electronic Engine Control Module (ECM) with an LCD digital display. The generator set ECM control is mounted, behind the single door on the right hand side of the enclosure. The ECM is programmed with a cycle cranking sequence - 3 cycles of 10 seconds on / 10 seconds off, and a 5 minute cool down delay. The cool down delay can be changed in the field from 0 to 30 minutes from the front panel. Other features, timing cycles, set points and signal output capabilities are possible. Consult factory for additional information.

GENERATOR SET:

Every WINPOWER Generator Set has its own unique identity data plate. This data plate identifies the complete unit model number, the system serial number and has links to the individual components that form the generator set in our factory records. Several of the major components also have their own individual identity plates providing additional information to document build data for warranty and replacement parts.

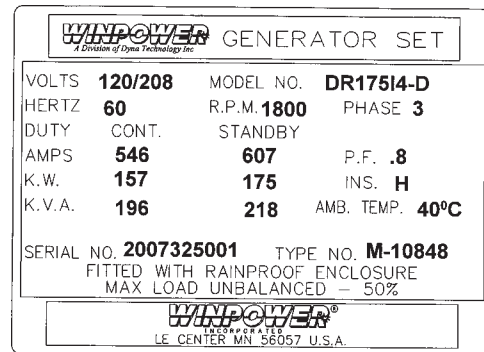

Typical Winpower Nameplate

Be sure to have the main WINPOWER unit data plate information recorded inside the front cover of this manual for future reference and for identification whenever requesting field or factory technical assistance. Sample data plate is shown for reference. Primary fields needed for assistance are complete model number, serial number and especially the M-Spec number. The M-Spec number (if provided) is recorded in the 'TYPE NO.' block on the Lower Right of the plate.

ENGINE:

This manual covers specific operation of the combined engine generator set. Refer to engine operating and maintenance instructions for specific instruction on the care and maintenance of the engine. Oil and fuel requirements along with maintenance schedules and engine warranty information are provided by the individual engine manufactures.

**** CAUTION ****

EQUIPMENT DAMAGE - Be sure to check the engine oil level frequently as specified in the engine manual.

The engine manufacturer has established an excellent worldwide engine service organization; engine service is available from a nearby authorized dealer or distributor; check the Yellow Pages of the telephone directory under "engines," or ask the dealer from whom you purchased the power plant.

The rated power of each engine-generator is limited by the temperature, altitude and all other ambient conditions specified by the engine manufacturer. Engine power will decrease 3-1/2% for each 1000 ft. above sea level, and will decrease an additional 1% for each 10 degrees Fahrenheit above 60 degrees Fahrenheit. Units should not be operated in ambient temperature greater than 125 degrees Fahrenheit.

GENERATOR:

WINPOWER Generators Sets use totally brushless, AVR (Auto-Voltage Regulator) controlled broad-range generator ends. The generator converts rotational mechanical energy into electrical energy. Standard WINPOWER units are equipped with generators manufactured by Stamford/Newage. Each generator 'end' has its own data tag. The unique serial number is stamped on the data plate and into the upper section of the mounting adapter of the generator frame. The data label is affixed to the main frame of the generator on the lower left side, similar to the sample shown.

SERIAL NUMBER	A068529666	NEWAGE
MACHINE ID	4/10	
FRAME / CORE	UC I224F1L 64D	NEWAGE INTERNATIONAL LTD
KVA BASE RATE (BR)	86.7	PO BOX 17, BARNACK RD
KW BASE RATE (BR)	71	STAMFORD, LINCOLNSHIRE
HZ	60	PE9 298, ENGLAND
RPM	1800	
VOLTS	208	
PHASE	3	
AMPS BASE RATE (BR)	247	43075 04/13/06
PF	0.8	WARNING
RATING	Standby	REFER TO THE INSTRUCTIONS BOOK
EX. VOLTS	36	BEFORE FLASH OR MEGA TESTING
EX. AMPS	1.8	
AMBIENT TEMP C	40	BS 5000: PART 3 IEC 34-
ENCLOSURE	IP22	NEMA MG 1-20 ISO 8528-3
INSULATION CLASS	H;UL1446	STAMFORD
STATOR WDG.	311	AC GENERATORS
STATOR CONN.	PARALLEL STAR	
AVR	5X460	
KVA PEAK RATE (BR)		
MAX HRS P A PR		
TEMP RISE	150	

ENGINE CONTROL MODULE (DSE 7310)

The DSE 7310 control modules provide integrated engine and generator set control, protection and metering in a single package. Microprocessor based technology allows for exact measurement, set point adjustment, and timing functions. Front panel controls and indicators enable quick and simple operation.

Fully configurable via PC software, allows units to be easily customized for each application. Includes selected front panel programming for on site changes. A wide temperature-range liquid crystal display (132 x 64) with backlighting can be viewed under a wide range of ambient light and temperature conditions.

FEATURES

DSE 7310 Control Modules have the following features:

- " Local and Remote Generator Control
- " Engine and Generator Protection
- " CAN Bus compatible
- " Programmable Logic
- " Automatic Transfer Switch Control (Mains Failure)
- " User Selectable RS232 & RS485
- " Five-key Menu Navigation
- " Engine Exercise Mode
- " Ethernet Communicating Via DSE860/865

FUNCTIONS

DSE 7310 Control Modules perform the following functions:

Generator Protection and Metering

Generator protection includes over voltage, under voltage, under frequency, over frequency and overload protection. Each generator protection function has an adjustable pickup and time delay setting. Metered generator parameters include voltage, current, real power (watts), power factor (PF)

Engine Protection and Metering

Engine protection features include oil pressure and coolant temperature monitoring, over crank protection, ECU specific protection elements, and diagnostic reporting.

Metered engine parameters include, oil pressure, coolant temperature, battery voltage, speed, engine load, coolant level (from ECU), ECU specific parameters, and run-time statistics.

**** NOTICE ****

These units will automatically transfer if a power outage occurs while running in an exercise mode.

RECEIVING THE GENERATOR

The generator set will generally be shipped by a commercial 'common freight carrier'. Routing is determined by the bulk, size, and a means available to unload the generator at the receiving end. WINPOWER recommends units that are shipped by common carrier be delivered to a commercial dock to allow the Generator Set to be unloaded in a safe, efficient manner and to minimize handling damage to the unit.

Locate the packing slip on the side of the crate or request it from the truck driver. When receiving the unit take special care in examining the unit for damage during shipment. Avoid signing for the equipment until a full visual assessment and inventory have been made. Verify that you have received the right equipment and the proper amount by matching up the equipment to the packing list.

The keys for doors of the enclosed generators sets are typically attached to housing louvers. These keys are matched to all the doors on the generator set housing.

UNPACKING INSTRUCTIONS:

When unpacking the generator set, be sure to inspect it carefully for freight loss or damage. If loss or damage is noted at the time of delivery, require that the person making the delivery make note of the loss or damage on the freight bill, or affix his signature under the consignee's memo of the loss or damage. Contact the carrier for claim procedures.

When loss or damage is noted after delivery, segregate the damaged material, and contact the carrier for claim procedures.

"Concealed Damage" is understood to mean damage to the contents of a package which is not in evidence at the time of delivery by the carrier, but which is discovered later. The carrier or carriers are responsible for merchandise lost or damaged in transit. The title to goods rests with the consignee when generators are shipped fob factory, and only the consignee can legally file a claim.

***** CAUTION ****

EQUIPMENT DAMAGE - These units are shipped with oil, and a 50/50 mix of coolant. Be sure to check all fluid levels before operating. See engine manufacturer's instruction manual for recommended oil requirements before initial starting.

UNPACKING:

(Not recommended until the unit is on-site)

1. Carefully remove the crate.
2. After inspecting the engine-generator for external physical damage, locate and check the following items packed with the unit.
 - a. Owner's operators manual.
 - b. Engine manufacturer's instruction manual.
 - c. Battery hold-down brackets & hardware.
 - d. Unit components or accessory items shipped loose for on-site installation.
 - e. Optional accessories (i.e. remote annunciator)
3. Remove main frame hold down bolts.
4. Unit can now be lifted from shipping rails.

LIFTING THE GENERATOR SET

NOTICE - Personal Injury

To prevent injury to persons or equipment, observe the following guidelines when lifting the generator:

Due to the different designs, configurations, options, weights, site conditions, and available material handling equipment, specific lifting instructions are not provided for each individual generator set model. General guidelines provided are applicable to the entire standby generator line. It is the responsibility of the installing party to follow the lifting equipment's operators manual to pre-

vent injury to personnel and damage to the generator. Smaller Generator Sets may not require use of overhead lifting equipment and may be placed on the pad with basic material handling equipment, i.e. a forklift.

CAUTION: - Do not attempt to lift the generator set by the means of the lifting eyes on the engine or generator end.

These lifting points are only for use during the manufacturing process and are designed for lifting of the individual Generator Set component.

WINPOWER has designed all of its Generators Sets to be lifted at the corners with an appropriate lifting rig. The lifting points are located on the side rails of the generator base or on the optional base mounted fuel tank of a Diesel Generator Set.

The generator set can be lifted with properly rated chains or cables along with the use of spreader bars. The spreader bars should be long enough so that the lift cables or chains do not come into contact with the generator set. Use of commercially available lifting fixtures may also be used. Always be sure that the equipment is properly rated for the weight of the generator. Failure to do so can cause damage to the generator, injury to personnel or even death.

The generator set and fuel tank may or may not be shipped as a complete unit. If the fuel tank is shipped separate from the generator, place the tank on the cement pad first, and then place the generator on top of the fuel tank.

***** WARNING ****

NEVER - attempt to lift the fuel tank while filled with fuel. Sloshing of the fuel can cause a shift in the balance of the fuel tank, making for a DANGEROUS, unbalanced lifting load. If the generator was shipped on the fuel tank, use the lifting points located on the fuel tank to move the entire Generator Set into place. DO NOT place fuel in the tank prior to lifting.

INSTALLATION

***** WARNING ****

PERSONAL INJURY - Before proceeding with the installation, be sure the engine control is in the "stop" position. Before proceeding with the installation, be sure the Generator MLCB (Main Line Circuit Breaker) is in the 'OFF' position and the unit starting battery is disconnected.

GENERAL INFORMATION

These engine/generator sets are generally supplied as weather enclosed packages for quick installation on an outdoor concrete pad. They are also available as open skid mounted units for indoor installation in a building or protective enclosure supplied by the installer. The factory weather enclosures are available as standard or acoustical housing intended for outdoor installation only. **Factory weather enclosed units are not intended to be used indoors and no support is available to assist in re-engineering finished packaged units.**

All versions must be bolted to a solid base for proper operation. A properly designed concrete pad is necessary for stationary operation. A substantial DOT certified trailer is required for mobile applications. Consult a qualified, licensed electrician or contractor to install and wire this Generator Set. **The installation must comply with all national, state, and local codes.**

Before beginning the installation process, recheck the voltage, phase and amperage rating of the Generator Set and ATS (Automatic Transfer Switch). Be certain they can handle the intended load and are compatible with the entrance voltage, phase and current ratings. Plans for installation should be prepared with proper attention to mechanical and electrical engineering detail to assure a satisfactory system installation.

The information in this manual is offered only as a guide to finalizing your installation plans.

NOTICE

For full service switching of the entire load, the ATS must be 'SE' (Service Entrance) rated or must have a properly rated fusible disconnect installed before the ATS to protect the contacts.

ENGINE GENERATOR SET MOUNTING

The unit's main frame must be bolted solidly to a 4 to 6 inch thick cement pad. The engine-generator is mounted on a sub-frame which is attached with special shock mounts to the main frame. This allows the engine-generator free movement without affecting the control panel which is mounted on the main frame.

Do not shock mount the main frame. Engine vibration will be transmitted to the control panel causing erroneous start/stop cycles and premature control failure.

The unit should be mounted to allow for ample working room around it. A general rule to follow is five (5) feet of clearance on all sides. (Code NFPA 37)

FUEL INSTALLATION

The fuel supply should be as close to the engine as possible. This will reduce the installation cost of fuel runs and minimize line losses. The diesel fuel supply should be no more than 3 feet below the fuel inlet on the pump. If your fuel supply is lower than three feet you may have to install an additional lift pump to bring the fuel up to the mechanical fuel pump on the engine.

The information in this manual is offered to assist you in providing the proper fuel for your engine. However, this information is only provided to inform you of the engine's requirements and assist in making you aware of the decisions you must make. In no case should the instructions or information provided be interpreted to conflict with any local, state or national codes. If in doubt, always consult your local fire marshal or fuel supplier.

INSTALLING THE FUEL LINE

Engine generator sets are properly adjusted before they leave the factory. Connecting a fuel supply with adequate supply volume is critical to reliable operation. Diesel units with optional base mounted fuel tanks are pre-plumbed to the mechanical fuel pump on the engine.

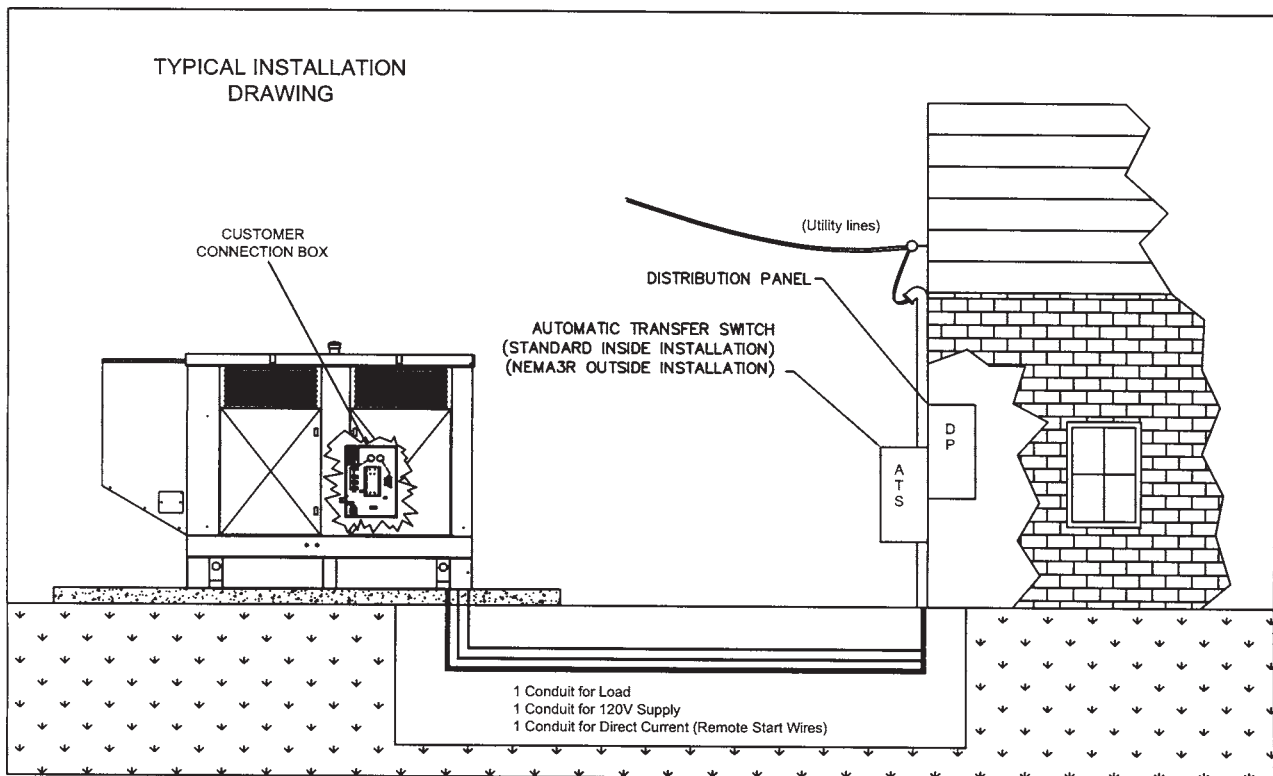

Open skid mounted Diesel units are often supplied with capped inlet and return lines. The use of a suitable customer supplied flexible fuel line is essential between the engine and fuel supply to provide a vibration break between your fuel supply and the engine.

***** **WARNING** *****

FIRE DANGER - Connecting rigid fuel line (i.e. steel or copper line) directly to the inlet fuel filter or fuel pump may cause the fuel line to crack during operation creating a serious fire hazard.

LUBRICATION

Before starting the engine, check the oil level in the crankcase. If it is low, refill to the full mark with the proper weight/grade of oil as recommended by the engine manufacturer's maintenance instructions. The necessity of using the correct oil, and keeping the crankcase full cannot be over emphasized. Failure to use the proper oil and keep the crankcase properly filled will cause excessive engine wear and shorten its useful life.

COOLANT

Before starting the engine, check the coolant level in the radiator. If it is low, refill as specified in the engine manufacturer's maintenance instructions. The radiator should be filled to about 1 inch below the filler neck. For additional information on engine coolant requirements see engine manufacturer's maintenance instructions.

INSTALLING THE BATTERY

**** **CAUTION** ****

In the following battery installation procedure, check to be sure the engine control is in the "stop" position. This should be your last step before initial start-up.

A customer supplied twelve-volt battery is required to complete the installation. Installation of the highest CCA rated battery, within the correct BCI group, will increase cold weather starting performance. *Gel batteries should not be used* with the battery tender installed in the generator enclosure.

BATTERY REQUIREMENTS

<u>Model</u>	<u>Voltage</u>	<u>BCI Group</u>	<u>MINIMUM CCA Rating</u>
DR20I	12	24	650

Installation and servicing of batteries must be performed or supervised only by personnel knowledgeable of batteries and the required precautions. Keep unauthorized personnel away from batteries.

When installing or replacing batteries, use the proper group/size **starting** battery. The battery should be a Maintenance Free lead acid design. Deep cycle batteries will not work for this application.

CAUTION – PERSONAL DANGER

CAUTION - NEVER dispose of a battery in a fire. The battery is capable of exploding.

CAUTION -DO NOT open or mutilate the battery. Released electrolyte is known to be harmful to the skin and eyes and to be very toxic.

These engine generator sets are all **NEGATIVE** ground. Be very careful not to connect the battery in reverse polarity, as this may short circuit the battery charging system on the engine.

CAUTION – A battery presents a risk of electrical shock and high short circuit current. The following precautions must be observed when working with batteries:

1. Remove watches, rings and other metal objects.
2. Use tools with insulated handles.
3. Check both the battery cable ends and the battery posts to be sure they are free of corrosion.
4. Always connect the battery positive cable first and then connect the battery negative cable. When removing the battery cables from the battery reverse the procedure, disconnect the negative cable first and then the positive cable.
5. Be sure all connections are tight and coat the terminals and cable ends with dielectric grease.

WARNING – The electrolyte is a diluted sulfuric acid that is harmful to the skin and eyes. It is electrically conductive and corrosive. The following precautions must always be taken:

- * Always wear full eye protection and protective clothing
- * Where electrolyte contacts the skin, wash off immediately with water
- * If electrolyte contacts the eyes, flush thoroughly and immediately with water and seek immediate medical attention
- * Spilled electrolyte is to be washed down with an acid neutralizing agent. A common practice is to use a solution of one pound of bicarbonate of soda (baking soda) to one gallon of water. The bicarbonate of soda solution is to be added until the evidence of reaction, foaming, has ceased. The resulting liquid is to be flushed with water and the area dried.

DANGER – Explosive Fire Risk

- * Never smoke when near batteries
- * Do not cause a flame or spark in the battery area
- * Always discharge static electricity from your body before touching batteries by first touching a grounded metal surface

SERVICING BATTERIES

Batteries used on these units may, over time, lose water. This is especially true if you are using a trickle charger to maintain your battery. When refilling the battery with water use only distilled water. Tap water will shorten the service life of the battery.

Never fill the battery above the fill line. Over filling above the upper level line may cause the electrolyte to overflow, resulting in corrosion to the engine or nearby parts. Immediately wash off any spilled electrolyte following the procedure above.

NOTE: Always make sure that a new battery is fully charged before installing it on a generator set. Failure to do so can cause damage to the engine control module in the generator set.

All connections must be clean and tight. Check the electrolyte (fluid) in the battery periodically to be sure it is above the plates. Never allow the battery to remain in a discharged condition.

CONNECTING THE BATTERY CHARGER & BLOCKHEATER

A two-stage battery tender is provided for all standby generators. These battery chargers can vary depending on what model you have purchased and what the original specifications call for. For unit operating at 12 volts D.C. the standard charger is a battery tender that charges at a rate of 750 mA until the battery is fully charged and then automatically switches to a 13.2 VDC float charger. The charger has an indicator light on it, red indicates it is charging, and green indicates it is in the storage mode (float charge). This charger is mounted on the left hand side of the AC connection cabinet.

** NOTICE **

The trickle charger is not intended to recharge a battery which has become completely discharged. It is designed to produce just enough current to maintain a fully charged battery.

The battery tender receptacle is to be powered by a GFCI circuit and installed in accordance with the United States National Electric Code. It is suggested that this circuit be fused for 20 amps. Then both the battery charger and the block heater can be connected to the same circuit. A 120 volt duplex receptacle is mounted on the generator along the side circuit breaker panel, for a 20 amp circuit and terminal blocks are provided.

The engine blockheater installed on this unit should also be plugged in this receptacle. The block heater is thermostatically controlled and when plugged in will maintain the engine coolant temperature between 100 and 120 degrees F.

MOUNTING THE AUTOMATIC TRANSFER SWITCH (A.T.S.)

**** WARNING ****

FIRE HAZARD - All wiring must be done by a licensed electrician, and must conform to the National Electrical Code and comply with all state and local codes and regulations. Check with the local authorities before proceeding!

INSTALLATION NOTES

Because of the many different types of service, feeder, and distribution equipment, no specific wiring instructions can be provided. It is recommended that only copper wire be used. In all cases it is essential that while the load is connected to the generator, there can be absolutely no feedback from the generator to the power line or the power line to the generator. When properly installed, the normal A.T.S. Control and safety systems will eliminate all paths for feedback.

To wire the automatic transfer switch into the existing wiring, first determine which circuits will be on the emergency load circuit. If the entire load is to be transferred, the transfer switch can be wired in directly after the watt-hour meter and the service entrance, providing the service entrance ampere rating is within the transfer switch's rated capability.

If only specific circuits are to be powered under emergency power failure conditions, an additional distribution panel designated "emergency distribution panel" must be installed.

All selected emergency circuits are removed from main distribution panels and installed in the emergency distribution panel. The A.T.S. is then installed between the main panel and the emergency distribution panel. Suggested circuits: freezer, refrigerator, furnace, emergency lights, sump pump, emergency outlet circuits, etc. Total running load must not exceed generator rating.

A.C. ELECTRICAL CONNECTIONS

**** WARNING ****

EQUIPMENT DAMAGE- If you are connecting to DR20 that has a voltage selector switch installed on, it read the information starting on page 17 before proceeding.

NOTICE - CLASS 1 WIRING METHODS ARE TO BE USED FOR ALL FIELD WIRING CONNECTIONS TO TERMINALS OF A CLASS 2 CIRCUIT

Note: This symbol  always indicates ground where shown.

All wiring must be completed in accordance with the Nation Electric Code as well as any state or local codes.

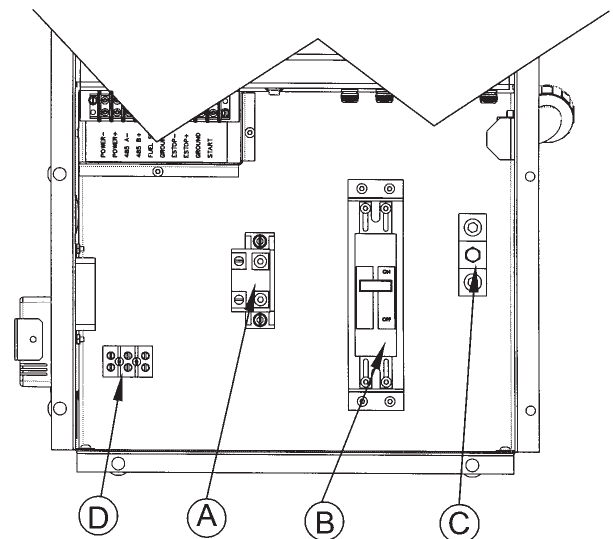

You must pay particular attention to wire size requirement for the amperage of service you are dealing with. The table below provides you guidance on wire sizing based on both wire type and amperage. **Wire amperage's have been derated for 40° C ambient temperatures operation.**

A - Neutral Lugs, These 100 amp neutral lugs are isolated from ground and provided for you to connect your neutral wire to from the transfer switch. The lugs will accommodate #12 AWG to #1/0 awg and should be torqued to 50 in. lbs.

B - Generator Circuit Breaker, This circuit breaker provides overload protection for the generator. Your power feeds from the transfer switch will connect to the bottom lugs on the circuit breaker. The generator power feeds have already been wired into the upper lugs.

The table below gives you the circuit breaker size, lug wire sizes and torque specification. (see the actual breaker for additional information and restrictions)

kW	Voltage	PH	Amp	Wire Capability	Lug Torque
20	120/240	1	83.0	#12 AWG -2/0 AWG	50 in lbs
20	120/208	3	69.5	#12 AWG -2/0 AWG	50 in lbs
20	120/240	3	60.2	#12 AWG -2/0 AWG	50 in lbs
20	277/480	3	30.1	#14 - #1/0 AWG	80 in lbs

Minimum Conductor Sizes between the Generator and the ATS. Based on wire type and temperature rating. Wire has been derated for 40° C ambient temperatures.

kW	Voltage	PH	C/B Amp	Cu Conductor		Al Conductor	
				75°C	90°C	75°C	90°C
20	120/240	1	85	#3 AWG	#4 AWG	#1 AWG	#2 AWG
20	120/208	3	70	#4 AWG	#6 AWG	#3 AWG	#4 AWG
20	120/240	3	60	#4 AWG	#6 AWG	#3 AWG	#4 AWG
20	277/480	3	30	#8 AWG	#8 AWG	#8 AWG	#8 AWG

For additional information on wire sizing refer to table 310-16 of the National Electrical Code ANSI/NFPA 70..

For additional information on wire sizing refer to table 310-16 of the National Electrical Code ANSI/NFPA 70.

C - Ground Lug, These ground lugs are bonded to ground and are provided for you to connect your ground wire from the transfer switch to. The lugs on the will accommodate #6 AWG to 250 MCM and should be torqued to 250 in. lbs.

D - 120 VOLT GFCI CIRCUIT TERMINAL BLOCK - These terminals are rated for 85 amps and will handle wire sizes #4 AWG to #18 AWG. They should be torqued to 16 in. lbs. This circuit must be fed from a fused circuit in the distribution panel and provides power for the blockheater and the battery charger.

WARNING *****

A main line circuit breaker has been provided inside the generator housing. During all wiring installations make sure the breaker is in the OFF position and the generator operation switch is in the OFF position.

WARNING *****

EQUIPMENT DAMAGE - When installing a Three Phase 240 volt system be sure you know which lead is the high voltage "wild" leg (208 Volt line to neutral). The generator normally carries the high voltage on the G2 lead.

All wires should be installed in rigid or flexible conduit. (Knock-outs are provided in the control box).

See the manual shipped with the Automatic Transfer Switch for connection locations in the switch. Connections in each switch will vary depending on the type of switch and the manufacturer.

GROUNDING

A grounding lug has been provided on the engine generator set and the generator set must be properly grounded to good earth ground. Generally a 8 foot copper rod driven into the earth will provide a proper earth ground.

D.C. ELECTRICAL CONNECTIONS

NOTE:

There are various DC connectors on the engine that have nothing connected to them. This was done intentionally, these connectors are for END OF LINE TESTING and other various diagnostic tests. They are not used during normal operations and can just be ignored.

All DC connections are completed on the terminal strip just below the engine control cabinet.

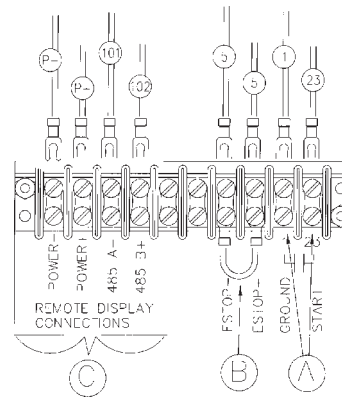

A - Customer Remote Start CONNECTIONS TERMINALS. The two remote start leads from the Automatic Transfer Switch are connected to the two terminals marked 1 & 23. The wire in terminal labeled #1 is Battery Negative and the wire in the terminal labeled #23 is your Remote Start lead. Closing these two leads together will signal the DSE 7310 to go into an auto-start mode and start up the engine generator.

Depending on the distance, 14 to 16 gauge stranded wire should be used. It is suggested that these wires be labeled S1 and S23. The terminal blocks are designed to use terminal lugs on all wires and the screws should be torqued to 9.6 in. lbs.

Note: Any relay closure can be used to start and stop this generator. As long as the contact stays closed the engine generator set will continue to run. Once the relay is opened the unit will shut down and remain in the standby mode until the remote start relay is closed again.

B - ESTOP- & ESTOP+. Remote Emergency Stop terminals. These two terminals are shipped with a jumper installed. If your application requires the installation of a Remote Emergency Stop switch, remove the jumper and wire your switch to these terminals. **This unit will not start and run without either the jumper installed or a remote N/C switch installed.**

C - Remote Display Panel Interface Terminals. These interface terminals are prewired to allow for the connection of a remote display. This display allows for the remote annunciation of alarms at a location such as a nurses station or a control room. This display can be used to meet the remote annunciation requirements of NFPA 110 standards.

DC Interconnections to the Automatic Transfer Switch

Two control wires are required between the A.T.S. panel and the generator control terminal box. Depending on the distance, 14 to 16 gauge stranded wire should be used. These wires should be labeled S1 (ground) and S23 (start).

 ***** **WARNING** *****

Be sure Engine Generator is in the "OFF" position before you make any DC interconnections.

*******CAUTION*******
Never run the AC and DC wiring in the same conduit.

Zenith ATS

The terminal markings in the Zenith ATS are marked "X1" and "X2". The wire labeled "Start 1" is routed to start contact "X1" and the wire labeled "Start 23" is routed to start contact "X2"

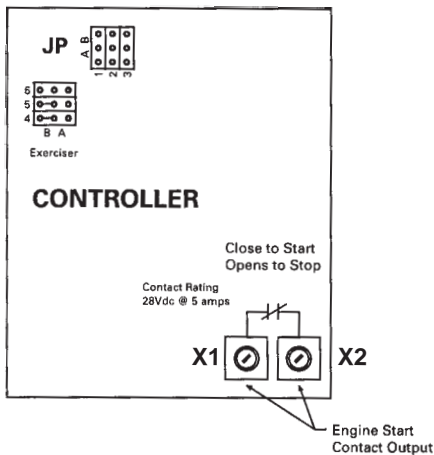

ASCO 165 UL SWITCH

Your DC connection points in the ASCO 165 ATS are terminals "4" and "5" on the interface terminal block.

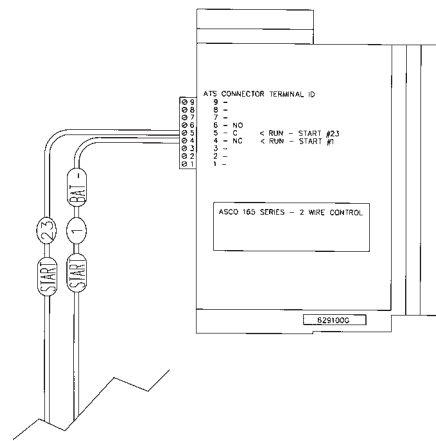

ASCO 300 UL SWITCH

Your DC connection points in the ASCO 300 ATS are terminals "14" and "15". Depending on the size of the switch they are located in different locations.

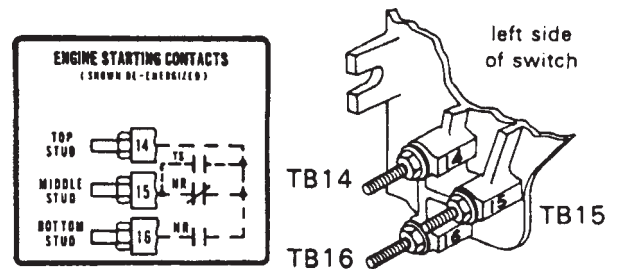
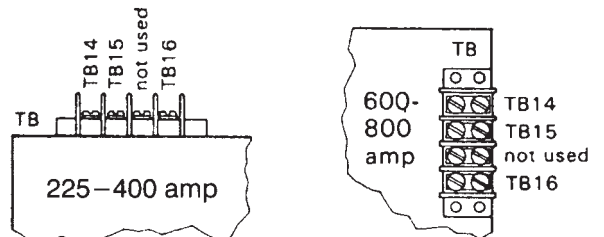
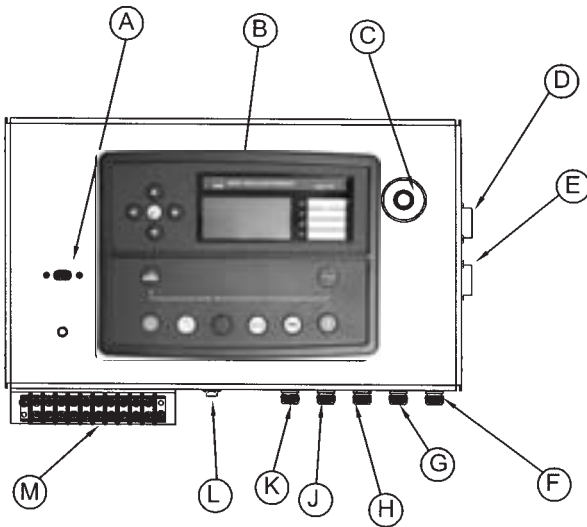

Figure 1-4. Engine starting contact label and location for 30 - 200 amp switches.



ENGINE CONTROL PANEL LAYOUT



A. USB PROGRAMMING PORT - USB port for computer interface. Used for programming the DSE7X10 controller.

B. DSE7310 CONTROLLER - See controller explanation on follow page.

C. Emergency Stop Switch - When depressed this switch will disconnect all the 12 volt power to the DSE7X10 shutting the engine down. The display on the controller will display "Emergency Stop".

D. AC INTERFACE CONNECTOR - This connector is used to interface with the AC generator end. It provides the controller with the voltage, amperage and frequency reading for the display.

E. DC INTERFACE CONNECTOR - This connector provides all the interface connections for the engine. Including the DC power supply to operate the DSE7X10 controller. Engine CAN connections are also made through this connector providing the controller with the engine operational reading.

F. 10 AMP FUSE This fuse supplies the DSE7X10 controller 12 Volt DC for all controller functions. (Replacement AGC-10A-250V)

G. 3 AMP FUSE -This fuse is in the power supply for the DSE7X10 controller circuitry on the board. (Replacement AGC-3A-250V)

H, J, K. 2 AMP FUSE- These fuses are in the AC input line from the generator. These are the feeds that provide the AC voltage reading on the display. If one of these is blown the controller will not show the proper voltage on one leg and may shutdown for low voltage. (Replacement AGC-2A-250V)

L. FUEL SELECTOR SWITCH - This switch changes the engine operating fuel form NG (with the switch open) to LP (with the switch closed) This selector switch tells the engine ECU what

fuel you are supplying. The engine ECU then makes the appropriate changes in the engine electronics to handle the fuel of your choice.

M. CUSTOMER REMOTE CONNECTIONS - See detail on pervious page.

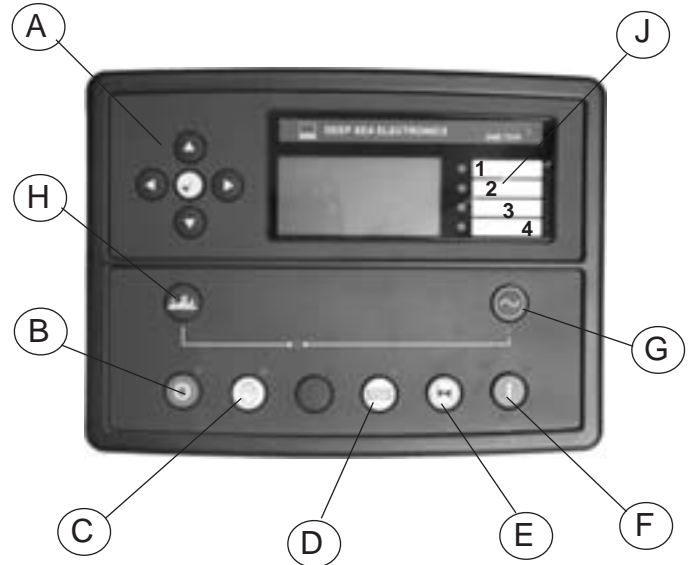

DSE 7310 CONTROLLER

A. MENU NAVIGATION BUTTONS – Left and Right buttons select different grouping (i.e. Engine reading Generator reading, etc) Up and down buttons scroll through the different reading for each group.

B. STOP/RESET – This button places the module into its STOP/RESET mode. This will clear an alarm conditions for which the triggering criteria have been removed. If the engine is running and this button is pushed the module will shut off the fuel solenoid and the engine will come to a stop. If a remote start signal is received while this switch is activated, the unit will not start.

C. MANUAL - This mode allows manual control of the generator functions. Once in the MANUAL mode the module will allow you to start the unit using the START button. The unit will continue to run until either the STOP/RESET or AUTO button is pressed. If the unit receives a remote start signal during manual operation, the generator will remain running even after the remote start signal has been lost. You must use the STOP/RESET or AUTO button to stop the unit once you have started it in manual mode.

**** CAUTION ****

IF THE POWER FAILS WHILE RUNNING IN THE MANUAL MODE THE TRANSFER SWITCH WILL TRANSFER THE LOAD TO THE GENERATOR. TO PREVENT THIS THE MAINLINE CIRCUIT BREAKER ON THE GENERATOR MUST BE OPENED.

D. AUTO – This button places the module into its AUTOMATIC mode. This module will monitor the remote start input for a relay closure. When the remote start signal is received it will time out the start delay (5 Seconds) and then start the engine generator set. When the remote start signal is lost (relay opens up) the module will shut the engine generator set down after the cool

down time has timed out. The module will return to the auto start mode and await the next start signal.

E. LAMP TEST/HORN RESET - This button silences the audible alarm if it is sounding and illuminates all of the LEDs as a lamp test feature. When configured and fitted to a compatible engine ECU, pressing this button in STOP/RESET mode after pressing the START button (to power the ECU) will cancel any “passive” alarms on the engine ECU.

F. START – This button is active only in the MANUAL or STOP/RESET mode. Pressing this button in the MANUAL mode will start the engine locally for testing. The engine will continue to run until either the STOP/RESET or the AUTO button is pressed. Pressing this button with the control in the STOP/RESET mode will turn on the CAN engine ECU (when correctly configured and fitted to a compatible engine ECU)

G. CLOSE GEN-SET – NOT USED IN THIS APPLICATION

H. OPEN GEN-SET – NOT USED IN THIS APPLICATION

J. USER CONFIGURABLE INDICATORS –

1. Generator has been start automatically.
2. Fuel Selection on for LP - off for NG.
3. Low Coolant Level - if installed (optional).
4. Generator supplying load.

NOTE: STOP/RESET, MANUAL mode and AUTO mode buttons all have indicator lamps next to them to tell you what mode you are in. Pressing buttons out of sequence will cause the engine not to do what you may think it should be doing. See button operation sequencing above.

INITIAL START UP

***** **WARNING** *****

EQUIPMENT DAMAGE - DO NOT jump start these engine generator sets. Starting these units on a low battery or jump starting them will cause damage to the engine control module.

Use the following check list to verify correct installation before starting the engine:

1. Engine oil. Fill as required with proper grade/qty.
2. Engine coolant. Fill as required with proper mixture.
3. Unit mounting base properly bolted down.
4. Clearance for service and maintenance on all sides.
5. Proper fuel line material and size.
6. All fuel line connections tight.
7. Battery connections clean and tight.
8. Battery fully charged.
9. All AC and DC wiring installed and properly protected.

After completing the above checklist, the engine-generator set is ready for the initial start-up test.

STARTING PROCEDURE

MANUAL MODE

***** **WARNING** *****

EQUIPMENT DAMAGE - BEFORE ATTEMPTING TO START THIS UNIT COMPLETE YOUR PRESTART CHECKLIST AND INSURE THE GENERATOR MAINLINE CIRCUIT BREAKER IS IN THE PROPER POSITION PRIOR TO STARTING. STARTING THIS UNIT WITHOUT IT PROPERLY CONNECTED CAN CAUSE SERIOUS PERSONAL INJURY OR EQUIPMENT DAMAGE.

1. Depress the manual mode button on the control panel. The small LED light next to it should come on.
2. Press the start button- The DSE7310 will send a start signal to the ECU on the engine. The engine ECU will then energize the fuel solenoid and start the cranking cycle (10 seconds on and 10 seconds off).

NOTE: There is no start delay in this mode of operation.

If the engine fails to start during this cranking period the starter motor is disengaged and goes into a rest mode after which a second attempt is made to start the engine. Should this sequence continue through 3 cranking cycles the start sequence will be stopped and the display will show ‘FAILED TO START’.

All engine functions are controlled by the ECU on the engine. The ECU on the engine will send information signals to the DSE7310 via the CAN connections to indicate oil pressure, water temperature, etc for the display on the engine control. All shutdown functions are also controlled by the ECU on the engine what you see displayed on the DSE7310 display is what is happening inside the ECU on the engine.

The AC output readings displayed on the DSE7310 are collected through the AC interface harness wired in the generator control box. An shutdowns related to the AC output are not a function of the engine ECU but are based on information collected in the DSE7310 via this AC harness.

4. During manual operation the load will not normally be applied to the generator. But caution must be used, if the line power should fail or be turn off to the transfer switch during manual operation the load may be applied to the generator.

With the engine running smoothly check the no load voltage and frequency on the digital display. The voltage should be 208/240/480 AC depending on which model you have and a frequency of 59.5 To 60.5 hertz (Hz).

If you have the proper voltage at the generator the next step is to check the voltage at the generator terminals in the Automatic Transfer Switch. The voltage between the G1 and the G3 terminals should be the same as it was on the generator front panel. The voltage should also be checked between the hot

terminals (G1 and G3) and the G-N to be certain of a balanced voltage output and a solid neutral connection. The voltage between G1 and G-N should be about 120 volts AC (277 on 480 units). The same approximate voltage should be found between terminals G3 and G-N (120 volts AC).

On three phase panels the G2 voltage level should also be checked. ON 240 VOLT (DELTA) SYSTEMS BE SURE YOU KNOW WHERE THE HIGH VOLTAGE "WILD" LEG IS. IT MUST BE IN THE SAME LOCATION ON THE LINE SIDE AS IT IS ON THE GENERATOR SIDE. (i.e. if it's on L-3 on the line side it must be on G-3 on the generator side.

**** Notice ****

If for any reason during the check out procedure the voltage and frequency are not correct, depress the STOP/RESET button and correct the trouble before proceeding.

5. Stopping – There are two ways to stop the unit when it is in the manual mode. Pressing the STOP/RESET button will stop the unit immediately. Pressing the AUTO mode button will stop the unit but only after the cool down timers have timed out and there is no remote start signal being sent to the unit.

AUTO MODE

To activate the automatic start mode you will just need to depress the AUTO button, the LED indicator beside the button confirms that the unit is in automatic start mode.

To test the automatic start Transfer Switches follow the instruction in the operator's manual you received with your transfer switch. If you get a fault light during the initial start up or prior to start up it is most likely a false warning light. Simply reset the ATS and start over.

Once you have completed testing of the ATS, be sure you ALWAYS leave the system in standby mode unless servicing the unit. For standby operation, press the AUTO button on the front of the engine control. The green light should light up next the AUTO button.

SETTING THE EXERCISER CIRCUIT

For all ATS see the instruction manual shipped with the ATS for instruction on setting the exercise circuit in your ATS.

TROUBLESHOOTING TABLES

Note: Before doing any troubleshooting, check the digital display on the DGC-2020. Normally it will tell why the unit has failed. This will shorten your troubleshooting time and in many cases prevent the replacement of parts that may not be defective.

UNIT WILL NOT CRANK WHEN THE POWER FAILS.

1. DSE controller not in "AUTO"
2. Transfer control switch defective.
3. Incorrect wiring between transfer switch and generator.
4. Fuse (s) blown in the DSE Controller.
5. Defective DSE7310 controller.
6. Loose or dirty battery terminals.

7. Defective starter.
8. Defective start solenoid.
9. Low/dead battery.

ENGINE WILL NOT CRANK WITH GENERATOR RUN PUSH-BUTTON DEPRESSED.

1. Low/dead battery.
2. Blown DC fuses on the DSE7310.
3. Defective DSE7310.
4. Loose or dirty battery terminals.
5. Defective starter.
6. Defective start solenoid.
7. Locked up engine genset.

ENGINE CRANKS BUT WILL NOT START

1. Improper fuel delivery to the unit.
2. Fuel supply shut off.
3. Fuel tank empty.
4. Air in the injection system.
5. Engine fuel rack has not opened.
6. Defective CANBus on the engine

ENGINE STARTS AND THEN STOPS AND ALARM LIGHT COMES ON

1. Engine is low on oil.
2. Engine has high water temperature.
3. Engine has overspeed.
4. Engine has gone into overcrank.
5. No output from AC generator.
6. Loss of speed signal.
7. Loss of run signal.

ENGINE WILL NOT COME UP TO SPEED AFTER IT STARTS

1. Insufficient fuel volume getting to the unit.
 - a. Too small of fuel line.
 - b. Fuel racks not opened properly.
2. Governor is defective.
3. AC short in generator components.

ATS PANEL WILL NOT TRANSFER TO EMERGENCY SUPPLY (GENERATOR)

1. No AC generator output from generator.
2. Defective ATS control board. See applicable transfer switch manual .
3. Circuit breaker between generator and transfer switch is either open or defective.

ATS PANEL WILL NOT RETRANSFER TO NORMAL POWER

1. Proper normal line power not available at line terminals in ATS panel.
2. Defective ATS control board. See applicable transfer switch manual .

NO AC OUTPUT FROM GENERATOR

1. Defective diode.
2. Defective voltage regulator.
3. Defective rotor.
4. Defective stator.
5. Defective exciter rotor.
6. Defective exciter stator.
7. AC short in the output leads.
8. Defective/open generator output breaker.
9. Wiring error.

DR20 NON SWITCHABLE DC SCHEMATIC

LEGEND

- AFI AIR FILTER INDICATOR
- ALT ALTERNATOR
- CH1 16 PIN (LARGE CONNECTOR) ENGINE CONTROL HARNESS
- CN2 14 PIN (SMALL CONNECTOR) ENGINE CONTROL HARNESS
- CN3 16 PIN (SMALL CONNECTOR) CONTROL PANEL HARNESS
- CTS COOLANT TEMPERATURE SENDER
- ESS EMERGENCY STOP SWITCH
- FS FUEL SOLENOID
- GRD GROUND (CHASSIS OR FRAME)
- GP ENGINE GLOW PLUGS
- GPR ENGINE GLOW PLUGS RELAY(50AMP)
- LFL LOW FUEL LEVEL
- LFL LOW FUEL LEVEL
- OPS OIL PRESSURE SENDER
- ROCT REMOTE CUSTOMER CONNECTION TERMINALS
- RR RUN RELAY
- SM ENGINE STARTER MOTOR
- SS START SOLENOID
- VAR VOLTAGE ADJUSTMENT RHEOSTAT
- PR PILOT RELAY
- PS POWER SWITCH

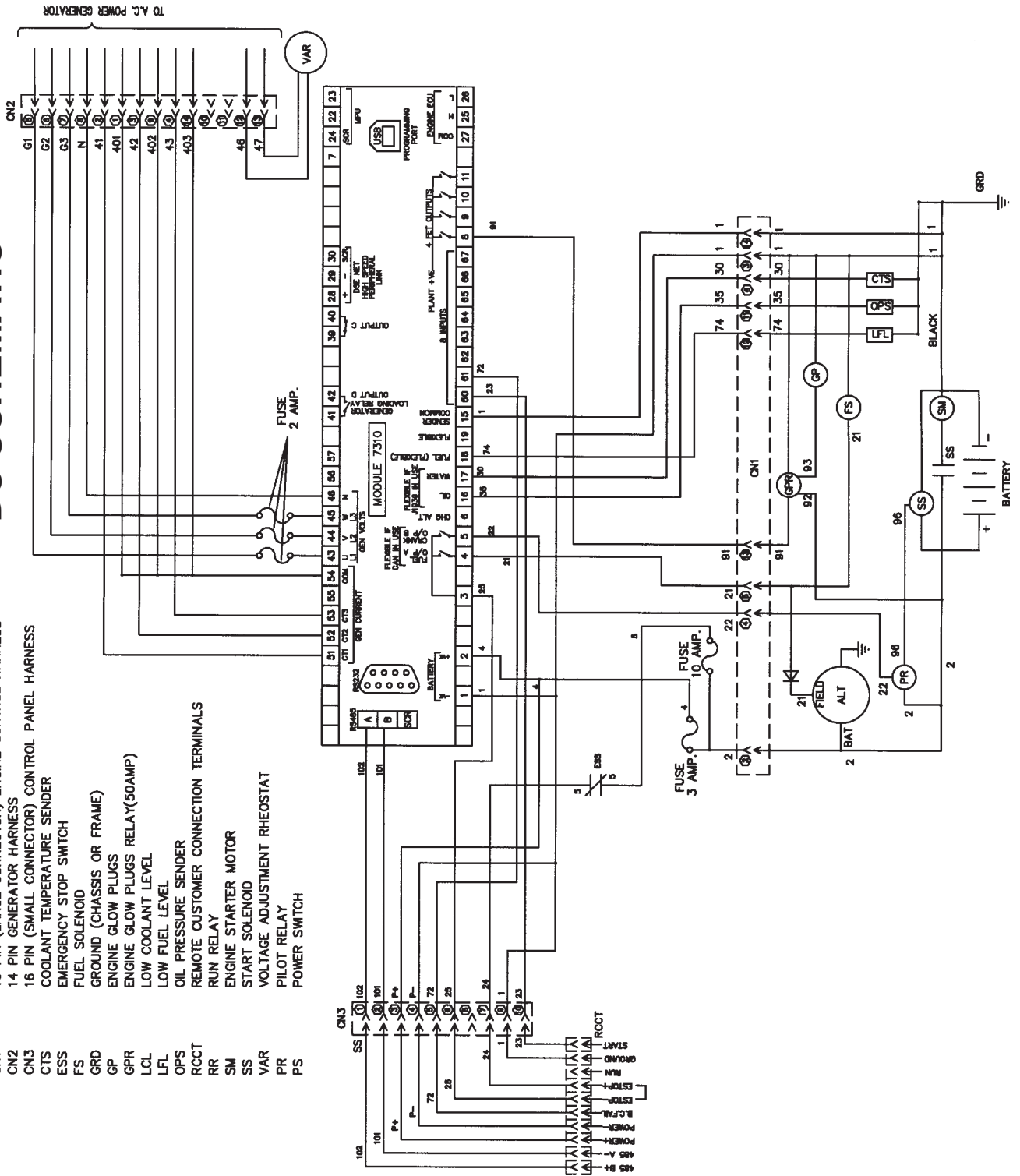

THREE PHASE AC WIRING - DELTA

SINGLE PHASE AC WIRING

SINGLE PHASE 120/240 VOLTS

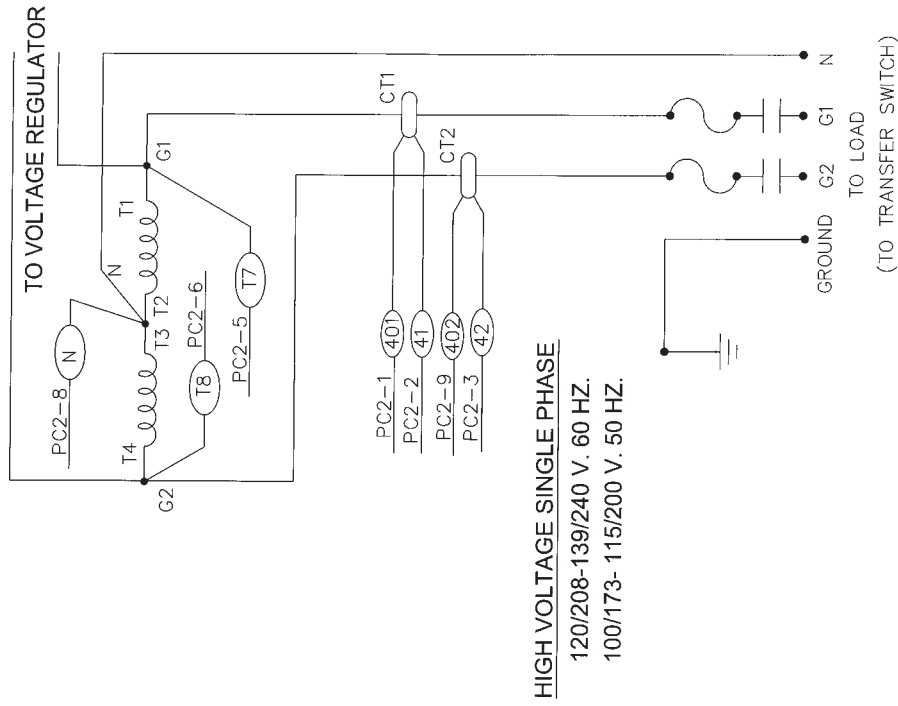

THREE PHASE -DELTA 120/240 VOLTS

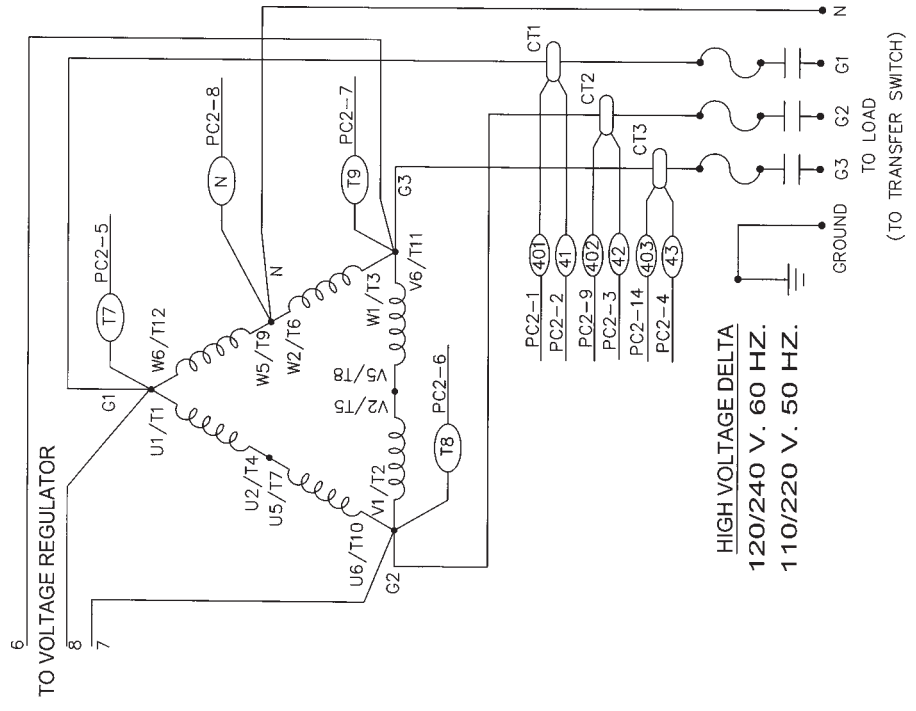

ENGINE WIRING HARNESS DR20

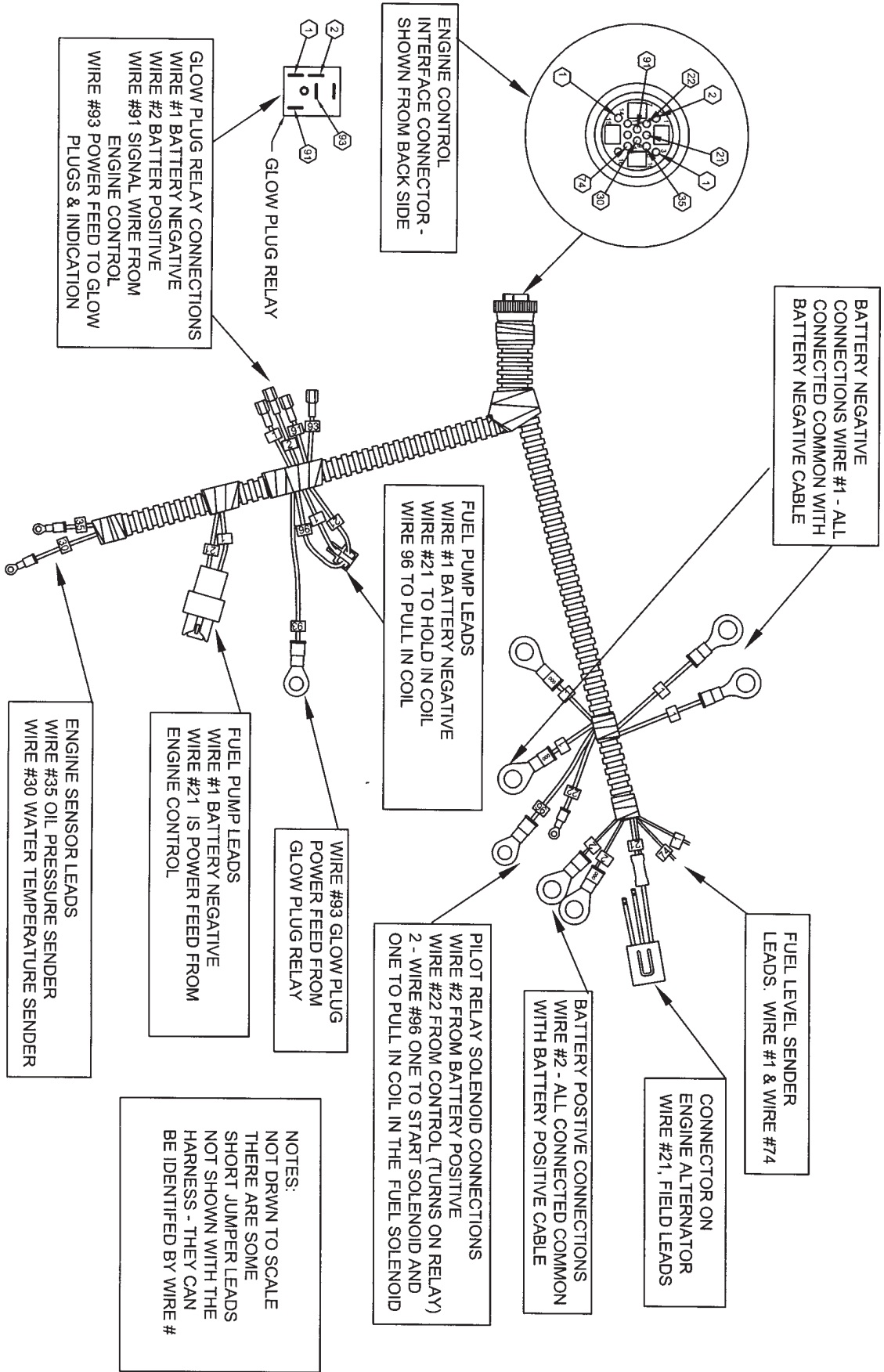

SUPPLEMENT INSTRUCTIONS FOR UNITS EQUIPPED WITH VOLTAGE SELECTOR

A variety of voltages are available from the four position selector switch. The four basic connection patterns are, Delta (120/240), Low or Parallel WYE (120/208), High WYE (277/480) and Single phase 120/240.

Before starting this unit be sure you have the selector switch set for the right voltage. You must depress the safety switch below the selector switch to change the position of the voltage selector switch. **If the unit is running depressing this switch will kill the engine generator set and display emergency shutdown on the control. Even if the unit is not running the control is disabled and you will need to press the reset button on the engine control before the unit can be restarted.**

If you have any doubts as to the voltage in your area compare your incoming power or load name plates to the voltage table below.

1. **120/240 Single Phase*** This configuration will produce the following line-to-line and line-to-neutral voltage. In this selector switch position, all of the receptacles on the front panel are powered.

- G1 - G3 240 Volts single phase
- G1 - N 120 Volts
- G2 - N Dead
- G3 - N 120 Volts

2. **120/240 Three Phase*** (Delta/Series configuration) - This configuration will produce the following line-to-line and line-to-neutral voltage. In this selector switch position, all of the receptacles on the front panel are powered.

- G1 - G2 - G3 240 Volts three phase
- G1 - G2 240 Volts single phase
- G2 - G3 240 Volts single phase
- G1 - G3 240 Volts single phase
- G1 - N 120 Volts
- G2 - N 208 Volts
- G3 - N 120 Volts

WARNING - POTENTIAL EQUIPMENT DAMAGE
THIS DELTA CONFIGURATION HAS A WILD LEG THAT PRODUCES 208 VOLTS LINE TO NEUTRAL ON G2. BE SURE WHEN CONNECTING TO YOUR PANEL OR LOAD THAT YOU MATCH THE WILD PHASE ON THE GENERATOR TO THE WILD PHASE IN YOUR PANEL OR LOAD. FAILURE TO DO SO WILL RESULT IN 120 VOLT DEVICES RECEIVING 208 VOLTS. YOU MUST ALSO MATCH YOUR ROTATION.

3. **120/208 Three Phase** (Low/Parallel WYE configuration) This configuration will produce the following line-to-line and line-to-neutral voltage. Use of this selector switch position allows utilization of the 120 volt receptacle only. The 240 volt receptacles cannot be used as the voltage at them will be 208 volts, the line to line voltage.

- G1 - G2 - G3 208 Volts three phase
- G1 - G2 208 Volts single phase
- G2 - G3 208 Volts single phase
- G1 - G3 208 Volts single phase
- G1 - N 120 Volts
- G2 - N 120 Volts
- G3 - N 120 Volts

4. **277/480 Three Phase** (High/Series WYE configuration) This configuration will produce the following line-to-line and line-to-neutral outputs.

- G1 - G2 - G3 480 Volts three phase
- G1 - G2 480 Volts single phase
- G2 - G3 480 Volts single phase
- G1 - G3 480 Volts single phase
- G1 - N 277 Volts
- G2 - N 277 Volts
- G3 - N 277 Volts

CIRCUIT BREAKER SELECTION

After you have selected the correct voltage for your application and locked the selector switch, you need to do the same with the main line circuit breakers.

Note: Refer to page 8 for torque specifications and wire capabilities for all breakers and lugs.

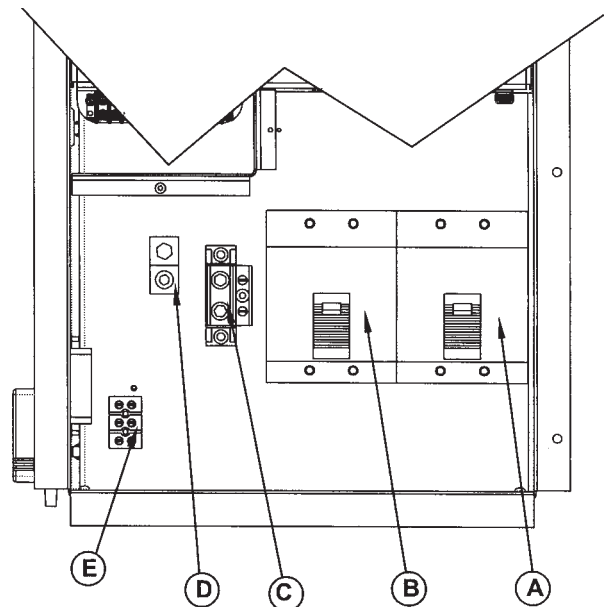

A - Generator Circuit Breaker, This circuit breaker is used for all low voltage connections (120/208 volt three phase. 120/240 volt three phase and 120/240 volt single phase).

B - Generator Circuit Breaker, This circuit breaker is used for all high voltage connections (277/480 volt three phase).

C - Neutral Lugs, used for all voltages.

D - Ground Lugs, used for all voltages.

E - 120 VOLT GFCI CIRCUIT TERMINAL BLOCK - These terminals are rated for 85 amps and will handle wire sizes #4 AWG to #18 AWG. They should be torqued to 16 in. lbs. This circuit must be fed from a fused circuit in the distribution panel and provides power for the blockheater and the battery charger.

- LEGEND**
- AFI AIR FILTER INDICATOR
 - ALT ALTERNATOR
 - CN1 16 PIN (LARGE CONNECTOR) ENGINE CONTROL HARNESS
 - CN2 14 PIN GENERATOR HARNESS
 - CN3 16 PIN (SMALL CONNECTOR) CONTROL PANEL HARNESS
 - CTS COOLANT TEMPERATURE SENDER
 - ESS EMERGENCY STOP SWITCH
 - FS FUEL SOLENOID
 - GRD GROUND (CHASSIS OR FRAME)
 - GP ENGINE GLOW PLUGS
 - GPR ENGINE GLOW PLUGS RELAY(50AMP)
 - LCL LOW COOLANT LEVEL
 - LFL LOW FUEL LEVEL
 - OPS OIL PRESSURE SENDER
 - RCT REMOTE CUSTOMER CONNECTION TERMINALS
 - RR RUN RELAY
 - SM ENGINE STARTER MOTOR
 - SS START SOLENOID
 - VAR VOLTAGE ADJUSTMENT RHEOSTAT
 - PR PILOT RELAY
 - PS POWER SWITCH
 - FP FUEL PUMP

DR20 SWITCHABLE VOLTAGE DC SCHEMATIC

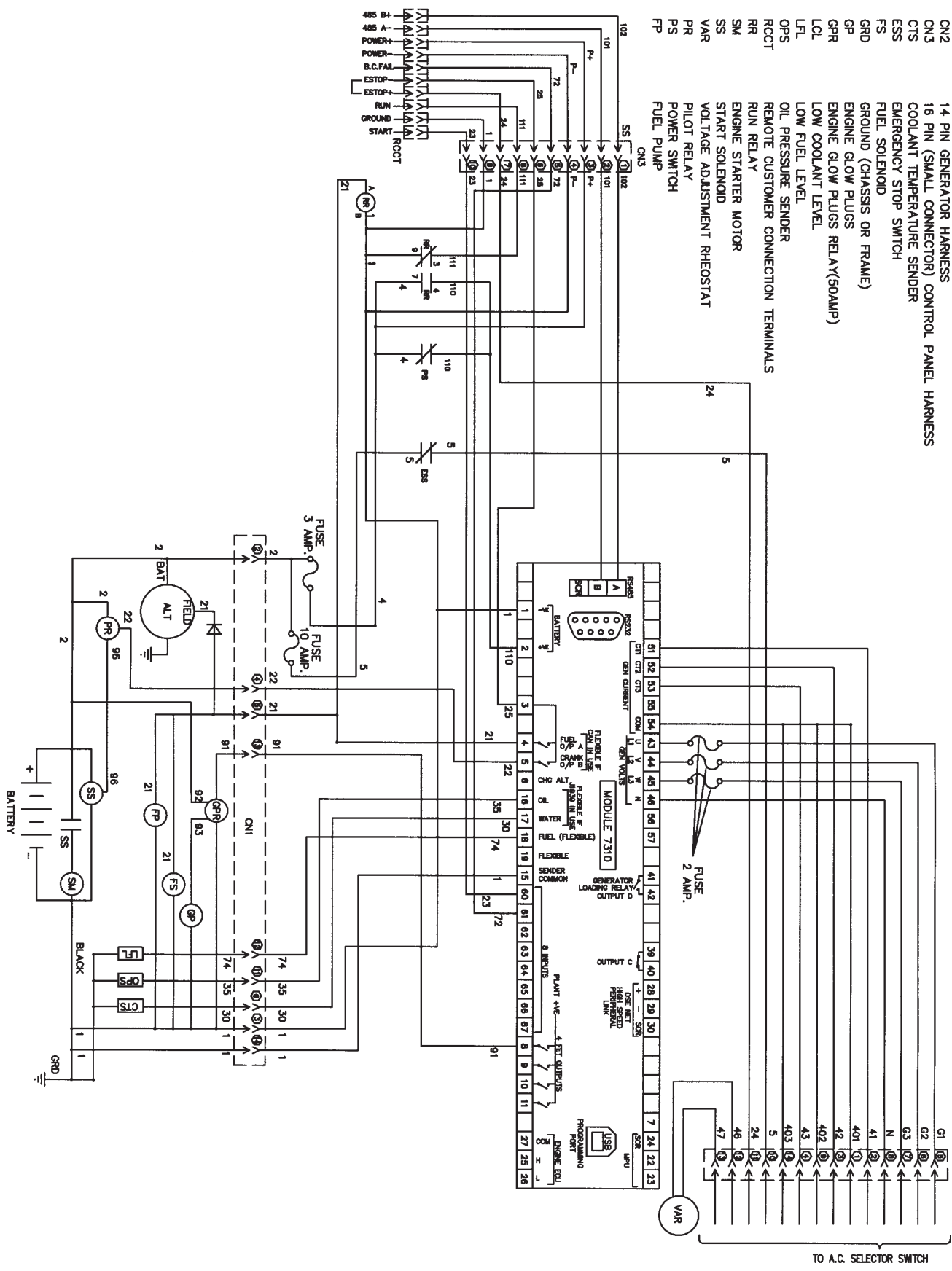

GENERATOR WIRING

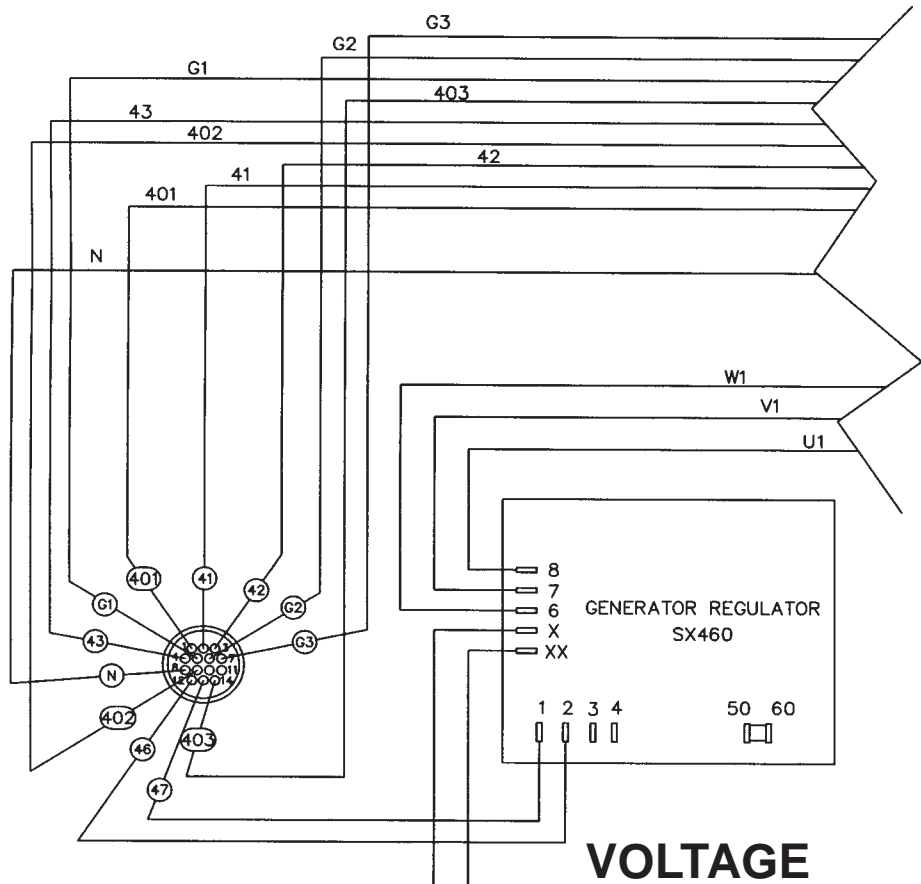

AC INTERFACE CONNECTOR

VOLTAGE

GENERATOR WIRING

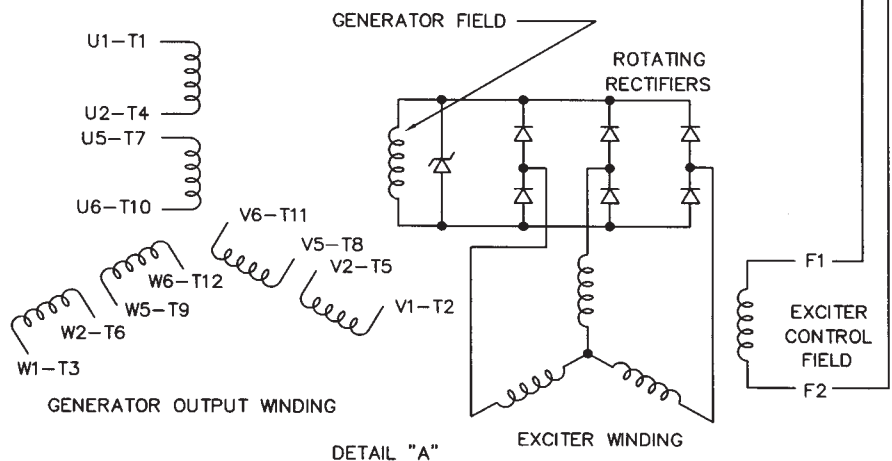

VOLTAGE SELECTOR SWITCH WIRING

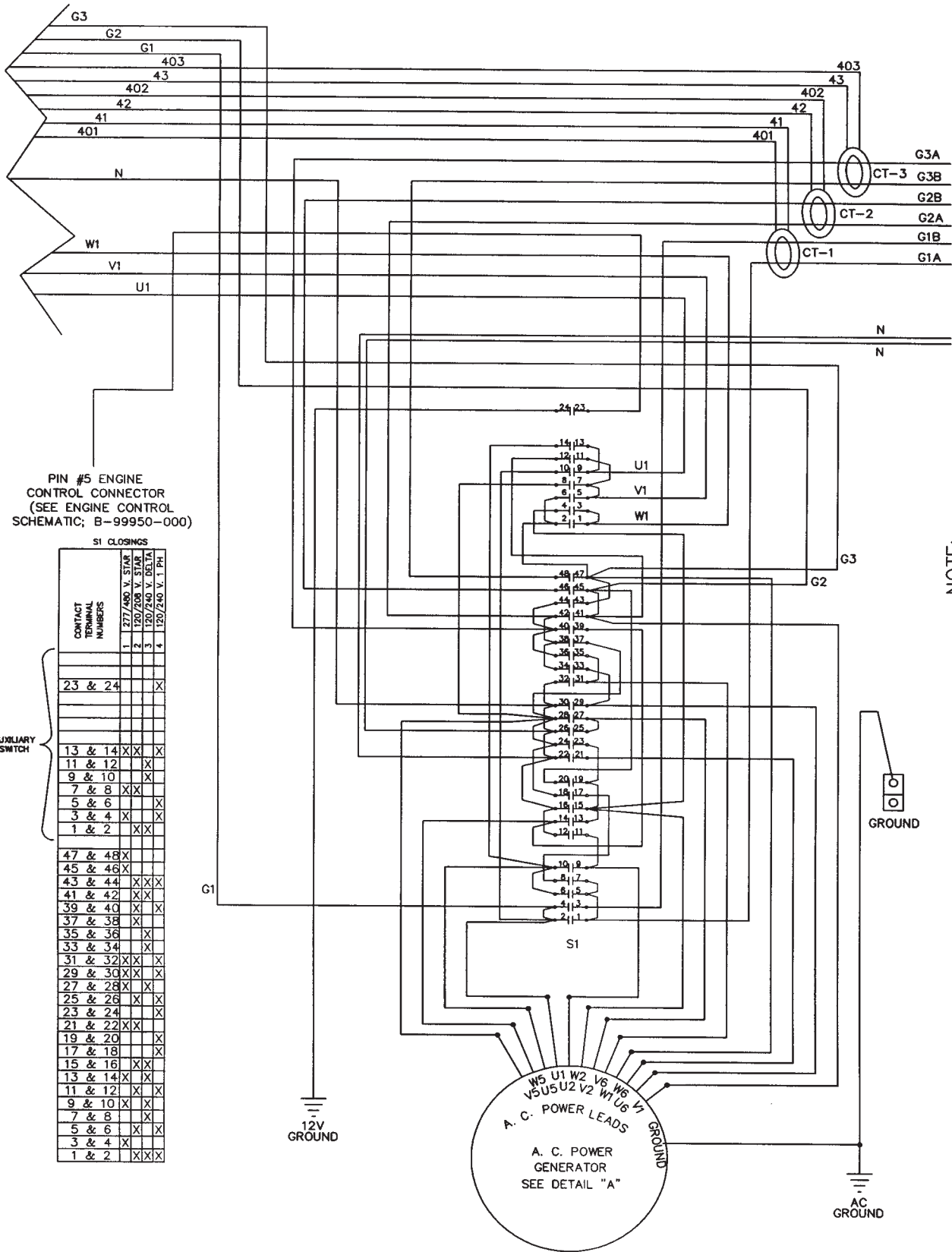

CIRCUIT BREAKER WIRING

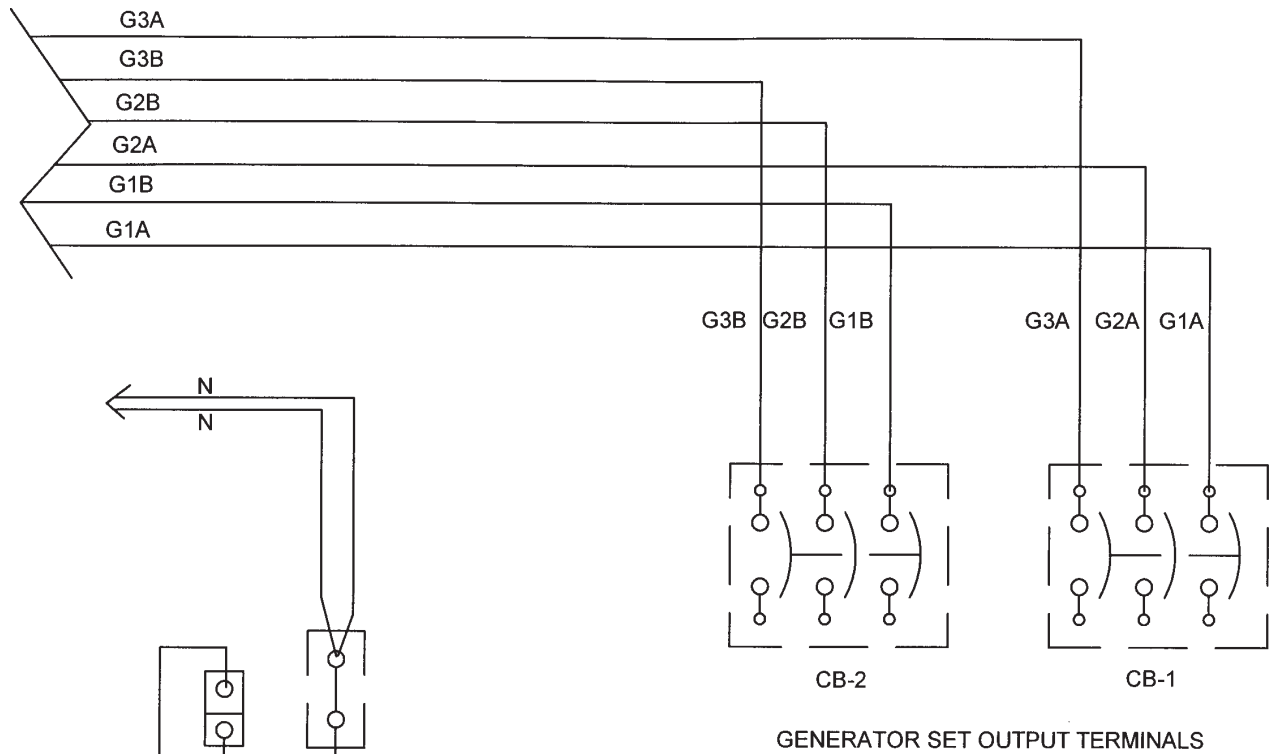







NOTE:

G1A, G2A, & G3A ARE FOR LOW VOLTAGE
 G1B, G2B, & G3B ARE FOR HIGH VOLTAGE

NEUTRAL TO GROUND BOND MUST BE
 INSTALLED WHEN RUNNING AS A STAND ALONE
 AND REMOVED WHEN THE GENERATOR IS
 CONNECTED TO AN EXISTING WIRING SYSTEM.





MODE ICONS

An icon is displayed in the mode icon area of the display to indicate what mode the unit is currently in.













Icon	Graphic	Details
Stopped		Appears when the engine is at rest and the unit is in stop mode.
Auto		Appears when the engine is at rest and the unit is in auto mode.
Manual		Appears when the engine is at rest and the unit is in manual mode/
Timer animation		Appears when a timer is active, for example cranking time, crank rest etc.
Running animation		Appears when the engine is running, and all timers have expired, either on or off load. The animation rate is reduced when running in idle mode.
Front panel editor		Appears when the unit is in the front panel editor.

AUTO RUN ICONS

When the engine is running in AUTO mode, an icon is displayed to indicate the reason for the set being run.

Auto run reason	Icon
Remote start input	
Low battery run	
Scheduled run	
Mains failure	

INSTRUMENTATION ICONS

















Icon	Graphic	Details
Generator		Used for generator voltage and generator frequency
Mains		Used for mains voltages and mains frequency
Engine speed		Engine speed instrumentation screen
Hours Run		Hours run instrumentation screen
Battery voltage		Battery voltage instrumentation screen
Engine temperature		Coolant temperature instrumentation screen
Oil pressure		Oil pressure instrumentation screen
Flexible sensor		Flexible sensor instrumentation screen
Event log		Appears when the event log is being displayed
Unit time		Current time held in the unit
Scheduler setting		The current value of the scheduler run time and duration
CAN DTC		ECU diagnostic trouble codes
Generator Current		Generator current instrumentation screen

WARNING ALARMS

Warnings are non-critical alarm conditions and do not affect the operation of the generator system, they serve to draw the operators attention to an undesirable condition.

In the event of an alarm the LCD will jump to the alarms page, and scroll through all active warnings and shutdowns.





















Warning alarms are self-resetting when the fault condition is removed.

Display	Reason
 Battery High Voltage	The DC supply has risen above the high volts setting level for the duration of the high battery volts timer
 Battery Low Voltage	The DC supply has fallen below the low volts setting level for the duration of the low battery volts timer
 CAN ECU Warning	The engine ECU has detected a warning alarm and has informed the DSE module of this situation. The exact error is also indicated on the module's display.
 Charge Alternator Failure	The auxiliary charge alternator voltage is low as measured from the W/L terminal.
 Digital Input A-D	Auxiliary Digital inputs can be user configured as Digital inputs and will display the relevant icon.
 Analogue Input A-C	Auxiliary Analogue inputs can be user configured as Digital inputs and will display the relevant icon.
 Fail To stop	The module has detected a condition that indicates that the engine is running when it has been instructed to stop. NOTE:- 'Fail to Stop' could indicate a faulty oil pressure sensor - If engine is at rest check oil sensor wiring and configuration.
 Generator High Voltage Warning	The generator output voltage has risen above the pre-set pre-alarm setting.
 Generator Low Voltage Warning	The generator output voltage has fallen below the pre-set pre-alarm setting after the <i>Safety On</i> timer has expired.
 High Coolant Temperature Warning	The module detects that the engine coolant temperature has exceeded the high engine temperature pre-alarm setting level after the <i>Safety On</i> timer has expired.
 Low Oil Pressure Warning	The module detects that the engine oil pressure has fallen below the low oil pressure pre-alarm setting level after the <i>Safety On</i> timer has expired.
 Low Fuel Level	The module detects that the fuel level is below the configured setting
 Over Frequency Warning	The generator output frequency has risen above the pre-set pre-alarm setting.
 Over Speed Warning	The engine speed has risen above the overspeed pre alarm setting
 Under Frequency Warning	The generator output frequency has fallen below the pre-set pre-alarm setting after the <i>Safety On</i> timer has expired.
 Under Speed Warning	The engine speed has fallen below the underspeed pre alarm setting
 Flexible Sensor	The flexible sensor warning alarm has been triggered.

SHUTDOWN ALARMS



Shutdowns are latching alarms and stop the Generator. Clear the alarm and remove the fault then press Stop/Reset  to reset the module.

 **NOTE:- The alarm condition must be rectified before a reset will take place. If the alarm condition remains, it will not be possible to reset the unit (The exception to this is the Low Oil Pressure alarm and similar 'delayed alarms', as the oil pressure will be low with the engine at rest).**

Display	Reason
 CAN CAN ECU Data Fail	The module is configured for CAN operation and does not detect data on the engine Can datalink, the engine shuts down.
 ECM CAN ECU Shutdown	The engine ECU has detected a shutdown alarm and has informed the DSE module of this situation. The exact error is also indicated on the module's display.
 Digital Input A-D	Auxiliary Digital inputs can be user configured as Digital inputs and will display the relevant icon.
 Analogue Input A-C	Auxiliary Analogue inputs can be user configured as Digital inputs and will display the relevant icon.
 Emergency Stop	The emergency stop button has been depressed. This is a failsafe (normally closed to battery negative) input and will immediately stop the set should the signal be removed.
 NOTE:- The Emergency Stop Negative signal must be present otherwise the unit will shutdown.	
 Fail To Start	The engine has not fired after the preset number of start attempts
 Generator High Voltage Shutdown	The generator output voltage has risen above the preset level
 Generator Low Voltage Shutdown	The generator output voltage has fallen below the preset level
 High Coolant Temperature Shutdown	The module detects that the engine coolant temperature has exceeded the high engine temperature shutdown setting after the <i>Safety On</i> timer has expired.
 Loss of Mag. Pickup Signal	The speed signal from the magnetic pickup is not being received by the DSE controller.
 Low Oil Pressure Shutdown	The engine oil pressure has fallen below the low oil pressure trip setting level after the <i>Safety On</i> timer has expired.
 Low Fuel Level	The module detects that the fuel level is below the configured setting
 Over Frequency Shutdown	The generator output frequency has risen above the preset level
 Over Speed Shutdown	The engine speed has exceeded the pre-set trip
 Under Frequency Shutdown	The generator output frequency has fallen below the preset level
 Under Speed Shutdown	The engine speed has fallen below the pre-set trip after the <i>Safety On</i> timer has expired.
 Temperature sensor open circuit	Temperature sensor has been detected as being open circuit.
 Oil pressure sensor open circuit	Oil pressure sensor has been detected as being open circuit.
 Flexible Sensor	The flexible sensor shutdown alarm has been triggered.
 Magnetic pickup open circuit	Magnetic pickup sensor has been detected as being open circuit.



ACCESSING THE FRONT PANEL CONFIGURATION

Ensure the engine is at rest and the module is in STOP mode by pressing the Stop/Reset  button.

Press the Stop/Reset  and Info  buttons simultaneously

EDITING A PARAMETER

Enter the editor as described above

Press the  (left) or  (right) buttons to cycle to the section you wish to view/change.

Press the  (up or down) buttons to select the parameter you wish to view/change within the currently selected section.

To edit the parameter, press  to enter edit mode. The parameter begins to flash to indicate that you are editing the value.

Press the  (up or down) buttons to change the parameter to the required value.

Press  to save the value. The parameter ceases flashing to indicate that it has been saved.

To exit the editor at any time, press and hold the  button

⚠NOTE: - When the editor is visible, it automatically closes after 5 minutes of inactivity to ensure security.

⚠NOTE: - Values representing pressure are displayed as Bar, kPa and PSI. Values representing temperature are displayed as degrees Celsius and Degrees Fahrenheit.



Limited Warranty

WINPOWER, Incorporated warrants to the original purchaser for 12 months or 1000 hours which ever occurs first, that goods manufactured or supplied by it will be free from defects in workmanship and material, provided such goods are installed, operated and maintained in accordance with WINPOWER written instructions.

WINPOWER's sole liability, and Purchaser's sole remedy for a failure under this warranty, shall be limited to the repair of the product. At WINPOWER's option, material found to be defective in material or workmanship under normal use and service will be repaired or replaced. For warranty service, return the product within 12 months or 1000 hours which ever occurs first from the date of purchase, transportation charges prepaid, to your nearest WINPOWER Authorized Service Center or to WINPOWER, Inc. at Le Center Minnesota.

THERE IS NO OTHER EXPRESS WARRANTY.

To the extent permitted by law, any and all warranties, including those of merchantability and fitness for a particular purpose, are limited to 12 months or 1000 hours which ever occurs first, from date of purchase. In no event is WINPOWER liable for incidental or consequential damages.

Note: Some states do not allow limitation on the duration of implied warranty and some states do not allow the exclusion or limitation of incidental or consequential damages, so the above limitations may not apply in every instance. This warranty gives you specific legal rights which may vary from state to state.

WINPOWER reserves the right to change or improve its products without incurring any obligations to make such changes or improvement on products purchased previously.

EXCLUSIONS:

WINPOWER does not warrant Engines. Engines are covered exclusively by the warranties of their respective manufacturers, see enclosed warranties.

WINPOWER does not warrant Batteries, or Other Component Parts that are warranted by their respective manufacturers.

WINPOWER does not warrant modifications or alterations which were not made by WINPOWER, Inc.

WINPOWER does not warrant products which have been subjected to misuse and/or negligence or have been involved in an accident.

WINPOWER
A Division of **DT** Dyna Technology Inc
225 S. Cordova
Le Center MN 56057
Phone - 507-357-6707
www.winpowerinc.com