

*A Division of **DTE** Dyna Technology Inc*

---

**NG & LP FUELED  
GENERATOR  
SYSTEMS**

**GRN340**

**GRP266**

**INSTALLATION AND  
OPERATIONS MANUAL**

# SAVE THESE INSTRUCTIONS

This manual contains important instructions that should be followed during installation and maintenance of the generator and batteries.

Read and understand all instructions in the manual before starting and operating the generator set.

## USING THIS MANUAL

Congratulations on your choice of a Winpower generator set. You have selected a high-quality, precision-engineered generator set designed and tested to give you years of satisfactory standby service.

To get the best performance from your new engine generator set, it is important that you carefully read and follow the operating instructions in this manual.

Should you experience a problem please follow the "Things To Check" near the end of this manual. The warranty listed in this manual describes what you can expect from WINPOWER should you need service assistance in the future.

## COPY YOUR MODEL AND SERIAL NUMBER HERE

No other WINPOWER generator has the same serial number as yours. It is important that you record the number and other vital information here. If you should ever need to contact us on this unit it will help us to respond to your needs faster.

MODEL \_\_\_\_\_

SERIAL NUMBER \_\_\_\_\_

M Spec. \_\_\_\_\_

PURCHASE DATE \_\_\_\_\_

DEALER \_\_\_\_\_

## TABLE OF CONTENTS

<b>INTRODUCTION</b>	i
<b>GUIDE TO PRODUCT SAFETY</b>	1
<b>BASIC INFORMATION</b>	2
Description	2
Specifications	3
Engine Control Layout	3
DGC-2020 Panel Layout/Functions	4
DGC-2020 Display Operations	5
<b>RECEIVING THE GENERATOR</b>	6
Unpacking the unit	6
Lifting the unit	7
<b>ENGINE GENERATOR INSTALLATION</b>	7
Installation	7
Engine Generator Set Mounting	8
Fuel Installation/Requirements	8
Vapor Fuel Pressures	9
LP Liquid Withdrawal	9
Lubrication	10
Coolant	10
Battery Installation	10
Battery Charger/Block Heater Wiring	11
Mounting The Transfer Switch	11
<b>AC ELECTRICAL CONNECTIONS</b>	11
<b>DC ELECTRICAL CONNECTIONS</b>	12
<b>INITIAL START-UP</b>	14
<b>EXERCISER CLOCK</b>	14
<b>TROUBLESHOOTING INFORMATION</b>	14
Wiring Sizing Table	16
Generator Connections	17
Single Phase 120/240	17
Three Phase 120/240 (Delta)	17
Three Phase 120/208 (Low WYE)	18
Three Phase 277/480 (High WYE)	18
Voltage Regulator Wiring	19
<b>DC WIRING DIAGRAM</b>	20
<b>12 MONTH WARRANTY</b>	21

## PROPER USE AND INSTALLATION

You must be sure your new engine generator set is:

- \* Properly serviced before starting
- \* Operated in a well ventilated area
- \* Properly exhausted and gases safely dispersed
- \* Wired by a qualified electrician
- \* Operated only for its designed purposes
- \* Used only by operators who understand its operation
- \* Properly maintained

# IMPORTANT SAFETY INSTRUCTIONS

## SAVE THESE INSTRUCTION

This manual contains important instructions that should be followed during installation and maintenance of the generator and batteries.

Read and understand all instructions in the manual before starting and operating the generator set.

This engine generator set has been designed and manufactured to allow safe, reliable performance. Poor maintenance, improper or careless use can result in potential deadly hazards; from electrical shock, exhaust gas asphyxiation, or fire. Please read all safety instructions carefully before installation or use. Keep these instructions handy for future reference. Take special note and follow all warnings on the unit labels and in the manuals.

## ANSI SAFETY DEFINITIONS

\*\*\*\*\*

### DANGER:

*DANGER indicates an imminently hazardous situation which, if not avoided, will result in death or serious injury. This signal word is to be limited to the most extreme situations.*

\*\*\*\*\*

\*\*\*\*\*

### WARNING:

*WARNING indicates a potentially hazardous situation which, if not avoided, could result in death or serious injury.*

\*\*\*\*\*

\*\*\*\*\*

### CAUTION:

*CAUTION indicates a potentially hazardous situation which, if not avoided, may result in minor or moderate injury. It may also be used to alert against unsafe practices.*

\*\*\*\*\*

### NOTE:

*CAUTION is also used on the unit labels and in this manual to indicate a situation that could result in serious damage or destruction of the equipment and possible personal injury.*

1. **ELECTRIC SHOCK** - The output voltage present in this equipment can cause a fatal electric shock. This equipment must be operated by a responsible person.
  - a. Do not allow anyone to operate the generator without proper instruction.
  - b. Guard against electric shock.
  - c. Avoid contact with live terminals or receptacles.
  - d. Use extreme care if operating this unit in rain or snow.
  - e. Use only three-prong grounded receptacles and extension cords.
  - f. Be sure the unit is properly grounded to an external ground rod driven into the earth.

2. **FIRE HAZARD** - LP and NG fuel presents a hazard of possible explosion and/or fire if not properly handled.
  - a. Do not smoke or use open flame near the generator set.
  - b. Keep a fire extinguisher nearby and know its proper use. Fire extinguishers rated ABC by NFPA are appropriate.
3. **DEADLY EXHAUST GAS** - Exhaust fumes from a LP/NG engines contain carbon monoxide, an invisible, odorless and deadly gas that must be mixed with fresh air.
  - a. Operate only in well ventilated areas.
  - b. Never operate indoors without proper ventilation.
  - c. Never operate the unit in such a way as to allow exhaust gases to seep back into closed rooms (i.e. through windows, walls or floors).
4. **NOISE HAZARD** - Excessive noise is not only tiring, but continual exposure can lead to loss of hearing.
  - a. Use hearing protection equipment when working around this equipment for long periods of time.
  - b. Keep your neighbors in mind when permanently installing this equipment.
5. **CLEANLINESS** - Keep the generator and surrounding area clean.
  - a. Remove all grease, ice, snow or materials that create slippery conditions around the unit.
  - b. Remove any rags or other material that could create potential fire hazards.
  - c. Carefully wipe up any fuel or oil spills before starting the unit.
  - d. Never allow leaves or other flammable material to build up around the engine exhaust area.
6. **SERVICING EQUIPMENT** - All service, including the installation or replacement of service parts, **should be performed only by a qualified technician.**
  - a. Use only factory approved repair parts.
  - b. Do not work on this equipment when fatigued.
  - c. Never remove the protective guards, cover, or receptacle panels while the engine is running.
  - d. Use extreme caution when working on electrical components. High output voltages from this equipment can cause serious injury or death.
  - e. Always avoid hot mufflers, exhaust manifolds, and engine parts. They all can cause severe burns instantly.
  - f. Installing a generator set is not a "do-it-yourself" project. Consult a qualified, licensed electrician or contractor. The installation must comply with all national, state, and local codes.
  - g. Always make sure unit is disabled before placing your hands anywhere near the fan, belts, alternator or water hoses.

# TESTING POLICY:

Before any generator is shipped from the factory, it is fully checked for performance. The generator is loaded to its full capacity, and the voltage, current, and frequency are carefully checked.

Rated output of generators is based on engineering tests of typical units, and is subject to, and limited by, the temperature, altitude, fuel, and other conditions specified by the manufacturer of the applicable engines.

# INTRODUCTION AND DESCRIPTION

## PRODUCT DESCRIPTION:

This engine-generator set is designed for unattended remote start operation. It can be operated as part of a fully automatic standby power system or independently as a local start unit in a prime power system. The engine-generator set is fully tested at the factory prior to shipment to insure proper operation of each individual component as well as the total system's performance and reliability.

The engine generator set consists of a multi-cylinder, liquid cooled engine nominally operating at 1800 rpm. The generator frequency regulation is maintained by the engine governor to within +/- 1.5 hertz (cps), from no load to rated load for standard mechanical governors and to within +/- .5 hertz or better for units equipped with an electronic governor. The generator is a single bearing, direct drive, rotating field design. The generator is connected to the engine flywheel via flexible drive disks. The Generator Set is skid mounted with isolation mounts between the engine and base on all units.

Unit Orientation Note: All references used in this manual for unit familiarization, access and component locations on the Generator Set are oriented from a TOP (plan) VIEW with engine at the FRONT and generator to the REAR.

WINPOWER uses a common junction box for all customer control and power connections (both AC output and DC control). The common electrical junction box is always on the left side at the generator end of the machine.

A customer supplied 12 (or 24) Volt battery is required to complete the installation.

The engine is controlled and Generator Set operation is monitored for safe operation by a programmable microprocessor based Electronic Engine Control Module (ECM) with an LCD digital display. The Generator Set ECM control is mounted on a vertical pedestal on the right side of the generator. The ECM is programmed with a cycle cranking sequence - 3 cycles of 15 seconds on / 15 seconds off, and a 5 minute cool down delay. The cool down delay can be changed in the field from 0 to 30 minutes by your dealer. Other features, timing cycles, set points and signal output capabilities are possible. Consult factory for procedure and passwords.

## \*\* NOTICE \*\*

*These units will automatically transfer if a power outage occurs while running in an exercise mode.*

## MODEL NUMBER STRUCTURE:

The WINPOWER alpha-numerical numbering system consists of a base model designation, followed by an options section, separated by a dash mark. The base component of the model numbering system identifies an engine type, engine starting method, fuel type, kilowatt rating, engine manufacturer, and number of generator poles. Following the separation dash mark is the voltage connection and optional installed equipment. Options include features like weather enclosures (housing), and trailer options.

Please note that some features or packages, such as NFPA level I & II, do not have an indication place in this numbering system. They are issued and built with an M-Spec (i.e. M-10372) number which can be found on the WINPOWER data tag. When the M-Spec is present, supplemental inserts will accompany this standard manual providing information about the special equipment and features installed. The standard model numbering key that can be used along with the data tag information and/or M-spec supplements to determine the generator sets ratings and specifications

<b>WINPOWER</b>	
<b>MODEL NUMBERING SYSTEM</b>	
<b>BUILD YOUR GENSET REQUIREMENT FROM THE BOTTOM OF THE PAGE TO THE TOP</b>	
<b>T</b>	<b>TRAILER OPTION</b> IF PRESENT UNIT IS MOUNTED ON A TRAILER WITH FUEL TANK FUEL. TANK SIZES SHOWN BY PREVIOUS LETTER (SMALL AND MEDIUM FUEL TANKS ONLY)
<b>M</b>	<b>FUEL TANK SIZE</b> S = SMALL      L = LARGE      SEE CURRENT PRICE SHEET M = MEDIUM   * = NONE      TO DETERMINE CAPACITY
<b>H</b>	<b>HOUSING TYPE</b> H = WEATHER HOUSING (WEATHER-PAK)   * = NO HOUSING A = SOUND ATTENUATED/WEATHER PROTECTIVE (SOUND-PAK)
<b>A</b>	<b>VOLTAGE</b> A = SINGLE PHASE 120/240      J = THREE PHASE 120/240 D = THREE PHASE 120/208      L = THREE PHASE 277/480
<b>-</b>	<b>BASE UNIT - OPTIONS SEPARATOR</b>
<b>4</b>	<b>NUMBER OF POLES ON THE GENERATOR</b> 4 POLES STANDARD
<b>I</b>	<b>ENGINE MANUFACTURE</b> V = VOLVO    I = ISUZU (10 & 20 kW)      G = GM D = DEUTZ    I = IVECO (ALL OTHERS)    N = NG ENGINES
<b>20</b>	<b>KILOWATTS</b> GENERATOR OUTPUT IN KILOWATTS WITH STANDBY
<b>N</b>	<b>GASEOUS FUEL TYPE</b> N = NATURAL GAS      L = L/P LIQUID WITHDRAWAL P = LIQUID PROPANE VAPOR    NOT USED WITH DIESEL FUEL
<b>R</b>	<b>STARTING METHOD</b> R - REMOTE STARTING
<b>G</b>	<b>FUEL TYPE</b> D = DIESEL G = GASEOUS

# SPECIFICATIONS

## GENERATOR SET:

Every WINPOWER Generator Set has its own unique identity data plate. This data plate identifies the complete unit model number, the system serial number and has links to the individual components that form the generator set in our factory records. Several of the major components also have their own individual identity plates providing additional information to document build data for warranty and replacement parts.

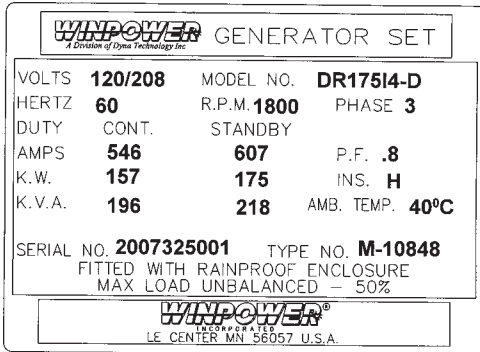

### Typical Winpower Nameplate

Be sure to have the main WINPOWER unit data plate information recorded inside the front cover of this manual for future reference and for identification whenever requesting field or factory technical assistance. Sample data plate is shown for reference. Primary fields needed for assistance are complete model number, serial number and especially the M-Spec number. The M-Spec number (if provided) is recorded in the 'TYPE NO.' block on the Lower Right of the plate. See the appendixes in the back of this manual for individual units specifications and wiring diagram references.

## ENGINE:

Each engine has a nameplate on it that gives the specific engine model number, build specification and the serial number for the engine. See the technical data pages in the back of this manual for individual engine specifications, fuel consumptions and wiring diagram references.

This manual covers specific operation of the combined engine generator set. Refer to engine operating and maintenance instructions for specific instruction on the care and maintenance of the engine. Oil and fuel requirements along with maintenance schedules and engine warranty information are provided by the individual engine manufactures.

**\*\* CAUTION \*\***

**EQUIPMENT DAMAGE** - Be sure to check the engine oil level frequently as specified in the engine manual.

The engine manufacturer has established an excellent worldwide engine service organization; engine service is available from a nearby authorized dealer or distributor; check the Yellow Pages of the telephone directory under "engines," or ask the dealer from whom you purchased the power plant.

The rated power of each engine-generator is limited by the temperature, altitude and all other ambient conditions specified by the engine manufacturer. Engine power will decrease 3-1/2% for each 1000 ft. above sea level, and will decrease an additional 1% for each 10 degrees Fahrenheit above 60 degrees Fahrenheit. Units should not be operated in ambient temperature greater than 125 degrees Fahrenheit.

## GENERATOR:

WINPOWER Generator Sets use totally brushless, AVR (Auto-Voltage Regulator) controlled broad-range generator ends. The generator converts rotational mechanical energy into electrical energy. Standard WINPOWER units are equipped with generators manufactured by Stamford/Newage. Each generator 'end' has its own data tag. The unique serial number is stamped on the data plate and into the upper section of the mounting adapter of the generator frame. The data label is affixed to the main frame of the generator on the lower left side, similar to the sample shown.

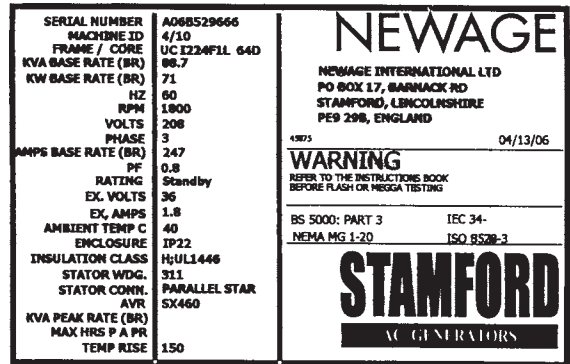

## ENGINE CONTROL PANEL LAYOUT

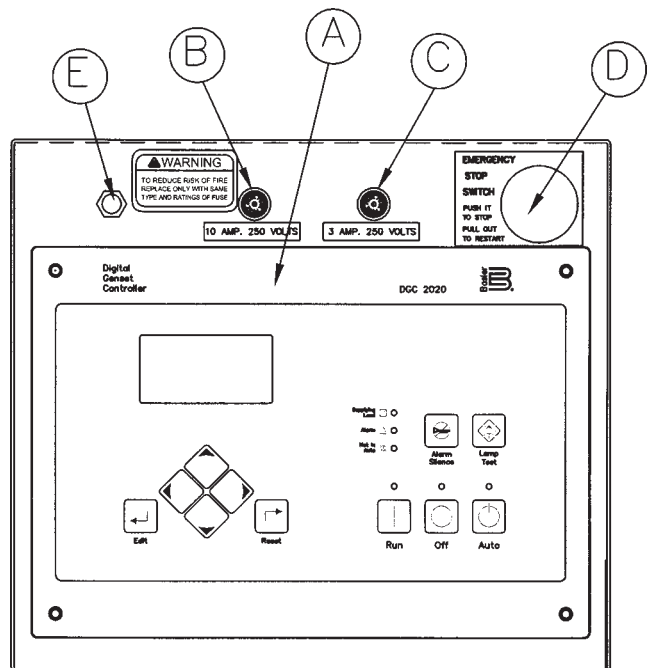

**A - DGC-2020 Digital Gen-Set Control.** See Explanation below.

**B - DC Control Circuit Fuse.** The 10 amp DC Circuit Fuse protects the 12 volt circuits and engine wiring harness against faults in wiring or control equipment. The fuse also prevents a discharge of the battery due to a circuit fault. (Replacement AGC-10A-250V)

**C - DGC-2020 Fuse.** This 3 amp DC fuse protects the DGC-2020 printed circuit board. (Replacement AGC-3A-250V)

**D - Emergency Stop Switch** - When depressed this switch will disconnect all the 12 volt power to the DGC-2020 shutting the engine down. The lamp in the emergency stop switch will light up when the switch is depressed showing that the power to the panel has been disconnected.

**E - Voltage Adjustment Rheostat.** This 2 watt 1k ohm rheostat is used to fine tune your output voltage from the generator. If for some reason the voltage should get way out of range and you can not get it back with the adjustment range on the rheostat, there is a course voltage adjustment pot on the voltage regulator

**ENGINE CONTROL MODULE (DGC-2020)**

**Note: A CD was shipped with this unit to support the DGC-2020. The CD contains the complete operators manual and the software to reprogram the DGC-2020 if the need should ever arise. Please store it in a safe place.**

The DGC-2020 Digital Generator Set Controller provides integrated engine-generator set control, protection, and metering in a single package. Microprocessor based technology allows for exact measurement, set point adjustment, and timing functions. Front panel controls and indicators enable

quick and simple DGC-2020 operation. Basler Electric communication software (BESTCOMSPPlus) allows units to be easily customized for each application. A wide temperature-range liquid crystal display (LCD) with backlighting can be viewed under a variety of ambient light and temperature conditions.

**FEATURES**

DGC-2020 Digital Generator Set Controllers have the following features:

- Local and Remote Generator Control
- Engine and Generator Protection
- Programmable Analog Engine Senders
- Programmable Logic
- Automatic Transfer Switch Control (Mains Failure)
- Integrated RS485 interface
- Auto Synchronizing

**FUNCTIONS**

DGC-2020 Digital Generator Set Controllers perform the following functions:

**Generator Protection and Metering**

Generator protection guards against over voltage, under voltage, under frequency, and over frequency. Over current and phase imbalance protection is available as an option at the time of manufacture. Each generator protection function has an adjustable pickup and time delay setting. Metered generator parameters include voltage, current, real power (watts), apparent power (VA), and power factor (PF).

**Engine Protection and Metering**

Engine protection features include oil pressure and coolant temperature monitoring, over crank protection, ECU specific protection elements, and diagnostic reporting.

**ENGINE CONTROL MODULE DGC-2020**

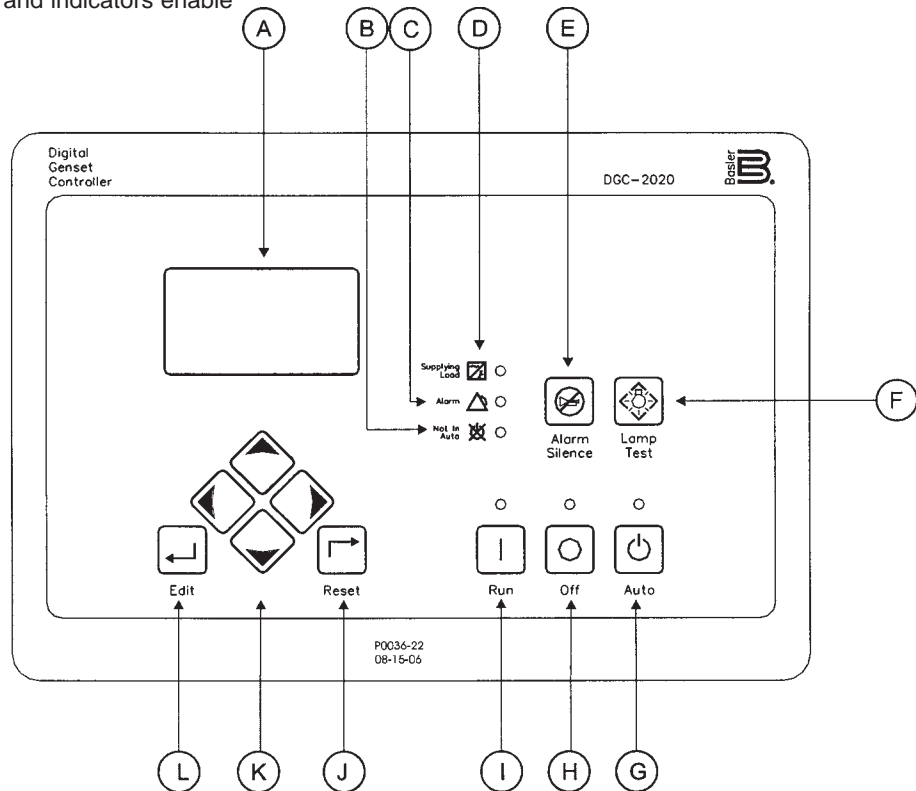

Metered engine parameters include oil pressure, coolant temperature, battery voltage, speed, engine load, coolant level (from ECU), ECU specific parameters, and run-time statistics.

All metering functions are displayed on the liquid crystal display. The front panel display begins with the SUMMARY SCREEN. Pressing the *Right* arrow key will open the MAIN MENU screen. The MAIN MENU screen consists of METERING and SETTINGS

### Summary Screen

Summary screen can be set to standard or scrolling. When set to standard, only the following are displayed:

- Generator Voltage
- Generator Amperage
- Generator Phase
- Generator Frequency
- Engine Oil Pressure
- Engine Coolant Temperature
- Engine Battery Voltage

**A - Liquid Crystal Display.** The backlit, 64 by 128 pixel LCD serves as the local information source for metering, alarms, pre-alarms and protective functions. Display operation is maintained at -20°C. An optional LCD heater would maintain display operation at -40°C.

**B - Not in Auto Indicator.** This red LED lights when the DGC-2020 is not operating in Auto mode.

**C - Alarm Indicator.** This red LED lights continuously during alarm conditions and flashes during pre-alarm conditions.

**D - Supplying Load Indicator.** This green LED lights when the generator current is greater than EPS threshold current.

**E - Alarm Silence Push-button.** Pressing this button opens the relay output programmed as the horn output.

**F - Lamp Test Push-button.** Pressing this button tests the DGC-2020 indicators by exercising all LCD pixels and lighting all LEDs.

**G - Auto Push-button and Mode Indicator.** Pressing the Auto button places the DGC-2020 in Auto mode. The green Auto mode LED lights when Auto mode is active.

**H - Off Push-button and Mode Indicator.** Pressing this button places the DGC-2020 in Off mode. The red Off mode LED lights when the DGC-2020 is in Off mode.

**I - Run Push-button and Mode Indicator.** Pressing this button places the DGC-2020 in Run mode. The green Run mode LED lights when Run mode is active.

**J - Reset Push-button.** This button is pressed to cancel a settings editing session and discard any settings changes. When pressed, this button also resets the Breaker Management Pre-Alarms

**K - Arrow Push-buttons.** These four buttons are used to navigate through the front panel display menus and modify settings. The left- and right-arrow buttons are used to navigate through the menu levels. The right arrow button is pressed to

move downward through the menu levels and the left-arrow button is pressed to move upward. Within a level, the up-arrow and down-arrow buttons are used to move among items within the menu level. Pressing the down-arrow button moves to items lower in the list. Pressing the up-arrow button moves to items higher in the list. During a settings editing session, the up- and down-arrow buttons are used to raise and lower the value of the selected setting.

**L - Edit Push-button.** Pressing this button starts an editing session and enables changes to the DGC-2020 settings. At the conclusion of an editing session, the Edit push-button is pressed again to save the setting changes.

### DISPLAY OPERATION

The front panel display is used to make settings changes and display metering values. Refer to call-outs J, K, and L in text and illustration for information on changing settings through the front panel and navigating through the Metering screens. When the unit is first powered up, the clock may need to be reset. Editing the clock provides familiarity with the edit process. All programming changes from the front panel are accessed through the edit key to begin and exit the internal microprocessor program.

#### Log-in and Permissions

To Log-in, navigate to the SETTINGS, ENTER PASSWORD screen and press the Edit key. Use the Up/Down arrow keys to scroll through the characters. Use the Left/Right arrow keys to enter more characters. The Owner operator password is OP. Once the password has been entered, press the Edit key to Log-in. See the key stroke sequence listed below to access the control and enter the edit mode. A LOGOUT selection now appears in the list of SETTINGS. To logout, navigate to SETTINGS, LOGOUT and press the Edit key. The LOGOUT selection is removed from the SETTINGS list.

Sequence for setting (or resetting) the system clock -

- 1) Press 'K' (right key) for initial set or 'K' (left to back up, up / down) to choose menu item and time/date element to be changed.
  - 2) Press 'L' (Edit) to access change mode to enter Password - OP as follows:
    - 2a -Press K (up) to select O
    - 2b -Press K (right) to move cursor
    - 2c -Press K (up) to select P
    - 2d -Press L (Edit) to begin change mode
  - 3) Press 'K' (up or down) to choose year
  - 4) Press 'L' (Edit) to enter year
  - 5) Press 'K' (down) to select month mode
  - 6) Press 'L' (Edit) to access month change
  - 7) Press 'K' (up or down) to choose month
  - 8) Press 'L' (Edit) to enter month
  - 9) Repeat sequence 5 through 8 for day, minute, second and DST (Daylight Saving Time).
- To finish clock setting, process - Press 'K' (left).

The microprocessor is still in the General Settings Edit mode. Pressing 'K' (left) a second time exits the Edit mode and allows full access to the View Only mode for all control settings and current status. Any items to be changed are accessed by pressing 'K' (up/down/right or left) to select, 'L' (Edit) to change and 'K' (left) to exit.

## Communication

Standard DGC-2020 communication features include a **standard USB port and SAE J1939 interface**. **Optional communication features** include a dial-out modem and RS-485 communication port. The **USB communication** port can be used with BESTCOMSPPlus software to quickly configure a DGC-2020 with the desired settings or retrieve metering values and event log records. The CANBus interface provides high-speed communication between the DGC-2020 and the engine control unit (ECU) on an electronically controlled engine. This interface provides access to oil pressure, coolant temperature, and engine speed data by reading these parameters directly from the ECU. When available, engine diagnostic data can also be accessed. The CANBus interface supports the following protocols:

- **SAE J1939 Protocol** - Oil pressure, coolant temperature, and engine speed data are received from the ECU. In addition, DTCs (Diagnostic Trouble Codes) help diagnose any engine or related failures. The engine DTCs are displayed on the front panel of the DGC-2020 and may be obtained using BESTCOMSPPlus software.
- **MTU/MDEC Protocol** - A DGC-2020 connected to a generator Set equipped with an MTU MDEC receives Oil pressure, coolant temperature, and engine speed data from the engine controller, along with various alarms and pre-alarms that are MDEC specific. In addition, the DGC-2020 tracks and displays the active fault codes issued by the MDEC ECU.

**Optional - Dial-Out Modem** One of two optional, dial-out modems (a US version or international version) enables remote control, monitoring, and setting of the DGC-2020. When an alarm or pre-alarm condition occurs, the DGC-2020 can dial up to four telephone numbers, in sequence, until an answer is received and the condition is annunciated.

**Optional - RS-485 Port** The RS-485 communication port uses the Modbus communication protocol and enables remote control and monitoring of the DGC-2020 over a polled network

## RECEIVING THE GENERATOR

The generator set will generally be shipped by a commercial 'common freight carrier'. Large and bulky units are often shipped on a dedicated or specially contracted 'Flat-Bed' truck. The means of shipment is determined in consultation between the WINPOWER Sales and Shipping staff and the customer. Routing is determined by the bulk, size, and a means available to unload the generator at the receiving end. WINPOWER recommends units that are shipped by common carrier be delivered to a commercial dock to allow the Generator Set to be unloaded in a safe, efficient manner and to minimize handling damage to the unit.

Locate the packing slip on the side of the crate or request it from the truck driver. When receiving the unit take special care in exam-

ining the unit for damage during shipment. Avoid signing for the equipment until a full visual assessment and inventory have been made. Verify that you have received the right equipment and the proper amount by matching up the equipment to the packing list. Larger units may ship with the fuel tank and muffler removed. Verify that those components are undamaged and removed from the truck prior to their release.

The keys for doors of the enclosed generators sets are typically attached to lifting eye on the base of the machine. These keys are matched to all the doors on the generator set housing.

## UNPACKING INSTRUCTIONS:

When unpacking the generator set, be sure to inspect it carefully for freight loss or damage. If loss or damage is noted at the time of delivery, require that the person making the delivery make note of the loss or damage on the freight bill, or affix his signature under the consignee's memo of the loss or damage. Contact the carrier for claim procedures.

When loss or damage is noted after delivery, segregate the damaged material, and contact the carrier for claim procedures.

"Concealed Damage" is understood to mean damage to the contents of a package which is not in evidence at the time of delivery by the carrier, but which is discovered later. The carrier or carriers are responsible for merchandise lost or damaged in transit. The title to goods rests with the consignee when generators are shipped fob factory, and only the consignee can legally file a claim.

\*\*\*\*\* CAUTION \*\*\*\*\*

***EQUIPMENT DAMAGE - These units are shipped with oil, and a 50/50 mix of coolant. Be sure to check all fluid levels before operating. See engine manufacturer's instruction manual for recommended oil requirements before initial starting.***

## UNPACKING:

(Not recommended until the unit is on-site)

1. Carefully remove the crate.
2. After inspecting the engine-generator for external physical damage, locate and check the following items packed with the unit.
  - a. Owner's operators manual.
  - b. Engine manufacturer's instruction manual.
  - c. Battery hold-down brackets & hardware.
  - d. Unit components or accessory items shipped loose for on-site installation.
  - e. Optional accessories (i.e. remote annunciator)
3. Remove main frame hold down bolts.
4. Unit can now be lifted from shipping rails.

## LIFTING THE GENERATOR SET

### NOTICE - Personal Injury

**To prevent injury to persons or equipment, observe the following guidelines when lifting the generator:**

Due to the different designs, configurations, options, weights, site conditions, and available material handling equipment, specific lifting instructions are not provided for each individual generator set model. General guidelines provided are applicable to the entire standby generator line. It is the responsibility of the installing party to follow the lifting equipment's operators manual to prevent injury to personnel and damage to the generator. Smaller Generator Sets may not require use of overhead lifting equipment and may be placed on the pad with basic material handling equipment, i.e. a forklift.

**CAUTION:** - Do not attempt to lift the generator set by the means of the lifting eyes on the engine or generator end.

These lifting points are only for use during the manufacturing process and are designed for lifting of the individual Generator Set component.

WINPOWER has designed all of its Generators Sets to be lifted at the corners with an appropriate lifting rig. The lifting points are located on the side rails of the generator base .

The generator set can be lifted with properly rated chains or cables along with the use of spreader bars. The spreader bars should be long enough so that the lift cables or chains do not come into contact with the generator set. Use of commercially available lifting fixtures may also be used. Always be sure that the equipment is properly rated for the weight of the generator. Failure to do so can cause damage to the generator, injury to personnel or even death.

Depending on generator set size and configuration, the exhaust system may 'ship loose' with the generator set for installation on site. The muffler and its attaching brackets must be mounted on top of the generator housing prior to operating the engine generator set.

## INSTALLATION

\*\*\*\*\*  
\*\*\*\* **WARNING** \*\*\*\*  
\*\*\*\*\*

**PERSONAL INJURY - Before proceeding with the installation, be sure the DGC-2020 is in the "stop" position. Before proceeding with the installation, be sure the Generator MLCB (Main Line Circuit Breaker) is in the 'OFF' position and the unit starting battery is disconnected.**

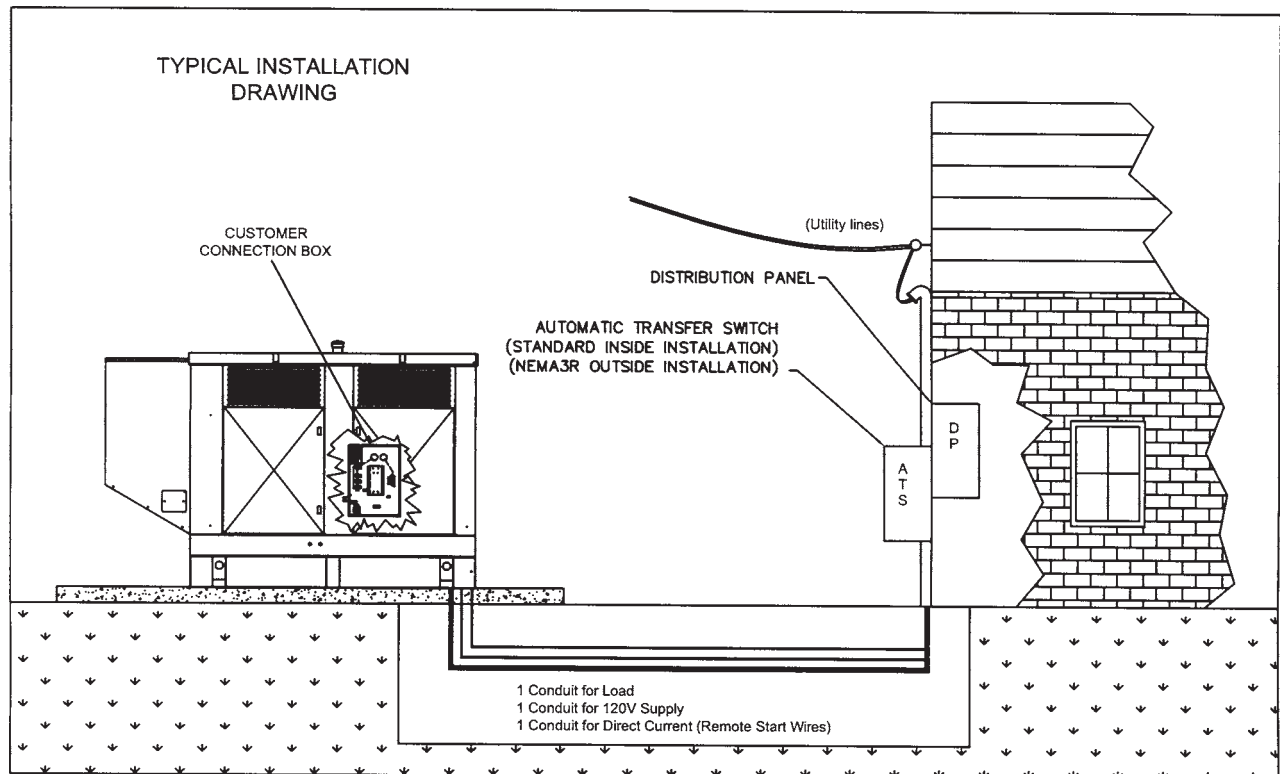

## GENERAL INFORMATION

These engine/generator sets are generally supplied as weather enclosed packages for quick installation on an outdoor concrete pad. They are also available as open skid mounted units for indoor installation in a building or protective enclosure supplied by the installer. The factory weather enclosures are available as standard or acoustical housing intended for outdoor installation only. **Factory weather enclosed units are not intended to be used indoors and no support is available to assist in re-engineering finished packaged units.**

All versions must be bolted to a solid base for proper operation. A properly designed concrete pad is necessary for stationary operation. A substantial DOT certified trailer is required for mobile applications. Consult a qualified, licensed electrician or contractor to install and wire this Generator Set. **The installation must comply with all national, state, and local codes.**

Before beginning the installation process, recheck the voltage, phase and amperage rating of the Generator Set and ATS (Automatic Transfer Switch). Be certain they can handle the intended load and are compatible with the entrance voltage, phase and current ratings. Plans for installation should be prepared with proper attention to mechanical and electrical engineering detail to assure a satisfactory system installation.

The information in this manual is offered only as a guide to finalizing your installation plans.

### NOTICE

For full service switching of the entire load, the ATS must be 'SE' (Service Entrance) rated or must have a properly rated fusible disconnect installed before the ATS to protect the contacts.

## ENGINE GENERATOR SET MOUNTING

The unit's main frame must be bolted solidly to a 4 to 6 inch thick cement pad. The engine-generator is mounted on a sub-frame which is attached with special shock mounts to the main frame. This allows the engine-generator free movement without affecting the control panel which is mounted on the main frame.

Do not shock mount the main frame. Engine vibration will be transmitted to the control panel causing erroneous start/stop cycles and premature control failure.

The unit should be mounted to allow for ample working room around it. A general rule to follow is five (5) feet of clearance on all sides. (Code NFPA 37)

## FUEL INSTALLATION

The fuel supply should be as close as possible to the engine. This will reduce the installation cost of fuel runs. The information in this manual is offered to assist you in providing the proper fuel for your engine. However, this information is only provided to inform you of the requirements and assist in making you aware of the decisions you must make. In no case should the instructions or information provided be interpreted to conflict with any local, state or national codes. If in doubt, always consult your local fire marshal or gas supplier.

\*\*\*\*\*

### \*\*\*\*\* WARNING \*\*\*\*\*

\*\*\*\*\*

**FIRE HAZARD** - All fuel runs should be installed by a licensed fuel supplier.

## FUEL CONSUMPTION

MODEL	NG (1,000 BTU/CU FT)		L.P. VAPOR (2,520 BTU/CU FT)			
	CF/HR	BTU/HR	#/HR	GAL/HR	CF/HR	BTU/HR
GRN340	4,272	4,272,593				
GRP266			153	35.94	1407	3,259,887

## L.P. TANK SIZING

Minimum required L.P. Tank size for L.P. Vapor withdrawal operation varies depending on your outside temperatures. Once you have your units LP requirement contact your local LP supplier to determine your minimum tank size requirements based on your lowest operating temperature. Buried tanks can be considerable smaller than tanks above ground as the bottom on the tank will enjoy the natural heat for the ground even during extremely cold periods.

Connect the fuel supply to the inlet of the fuel solenoid (see table for recommended line size). The pressure at the secondary demand regulator must be four to six ounces psi (per square inch) or 7 to 11 inches W.C. (Water column) for vapor withdrawal units. On units equipped with liquid withdrawal fuel systems full tank pressure is plumbed to the fuellock (solenoid) strainer mounted on the generator rails. The fuel converter mounted on the unit will handle both vaporization of the fuel and pressure reduction.

## INSTALLING THE FUEL LINE

### \*\* NOTICE \*\*

*The engine generator sets are properly adjusted before they leave the factory for a specific fuel, either N (natural gas), P (liquid propane vapor) or L (liquid withdrawal propane). This fuel type is noted in your model number.*

### Line Size (vapor system)

Unit location will determine the size of fuel line that is required to supply the engine with a constant fuel pressure. Refer to the tables below for fuel line diameter. For distances of 25 feet and over, a two regulator fuel system is recommended. This is accomplished by installing a primary regulator at the tank which will reduce the tank pressure down to 10 to 15 lbs. A secondary regulator is installed to further reduce the fuel pressure to the required six (6) oz. operating pressure. This secondary regulator should be at least 10 feet from the engine generator set. This will allow some storage of fuel and make it easier for the engine to accept load changes. If the second stage regulator is mounted directly on the unit the regulator may have trouble adjusting to large load increases during cold weather. Any closer installation will require a larger line be installed to provide a fuel reservoir. If this is not done, the demand regulator on the unit and the pressure regulator in the fuel line will interfere with each other. When this two (2) stage regulator system is used, consult your local fuel supplier for your exact requirements). The appropriate line size from the table below is then installed from the secondary regulator to the generator set.

\*\*\*\*\*

**\*\*\*\*\* WARNING \*\*\*\***

\*\*\*\*\*

**PERSONAL DANGER** - Do not use galvanized pipe in fuel line runs. The galvanized coating can become eroded and flake off, causing possible obstructions in the regulator or fuel valve. The results could range from inoperative engine start to hazardous fuel leaks.

Size of fuel line normally required for generators operating on NATURAL/LP gas:

MAXIMUM PROPANE CAPACITIES LISTED ARE BASED ON 1/2" W.C. PRESSURE DROP AT 11" W.C.

DISTANCE IN FEET	LINE SIZE				
	1.25"	1.5"	2"	3"	4"
10	2,205	3,307	6,221	17,990	36,710
20	1,496	2,299	4,331	12,510	25,520
30	1,212	1,858	3,465	10,110	20,620
40	1,039	1,559	2,992	8,481	17,300
50	913	1,417	2,646	7,708	15,730
60	834	1,275	2,394	6,936	14,150
80	724	1,086	2,047	5,908	12,050
100	630	976	1,811	5,309	10,830

Capacities in 1000 BTU/HR

**\*\*\*\*\* CAUTION \*\*\*\***

**EQUIPMENT DAMAGE** - Be careful when sealing gas line joints. Excessive sealing compound can be drawn into the solenoid, regulator or carburetor causing an engine malfunction.

**FUEL PRESSURE** (vapor system)

Correct fuel pressure cannot be stressed enough. The most common cause for inoperative systems is an inadequate or incorrect fuel pressure. Performance of the engine is in direct relation to the correctness of the fuel system. Shown below is a block diagram of a typical L.P. or N.G. Installation.

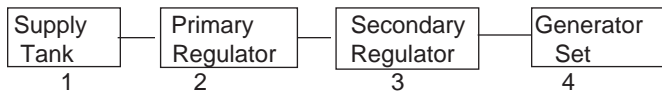

**TWO (2) REGULATOR FUEL SYSTEM**

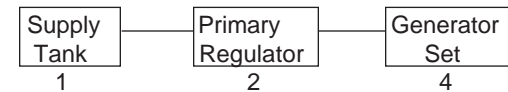

**SINGLE REGULATOR FUEL SYSTEM**

Reference numbers 1 through 3 in the block diagrams above are fuel lines supplied by customer.

Reference number 4 is the engine generator set.

Below is a table of the fuel pressure readings at each reference in the system.

**Fuel Pressure Table**

**Single Regulator (L.P. Vapor only)**

	1	2	3
UNIT OFF	TANK PSI	7-11 in 4-6 oz	7-11 in 4-6 oz
STARTING	TANK PSI	7-11 in 4-6 oz	7-11 in 4-6 oz
NO LOAD	TANK PSI	7-11 in 4-6 oz	7-11 in 4-6 oz
FULL LOAD	TANK PSI	7-11 in 4-6 oz	7-11 in 4-6 oz

**Two (2) Regulator System (L.P. Vapor only)**

	1	2	3	4
UNIT OFF	TANK PSI	10-15 lbs	7-11 in 4-6 oz	7-11 in 4-6oz
STARTING	TANK PSI	10-15 lbs	7-11 in 4-6 oz	7-11 in 4-6 oz
NO LOAD	TANK PSI	10-15 lbs	7-11 in 4-6 oz	7-11 in 4-6 oz
FULL LOAD	TANK PSI	10-15 lbs	7-11 in 4-6 oz	7-11 in 4-6 oz

**Natural Gas**

	1	2	4
UNIT OFF	LINE PSI	7-11 in 4-6 oz	7-11 in 4-6 oz
STARTING	LINE PSI	7-11 in 4-6 oz	7-11 in 4-6 oz
NO LOAD	LINE PSI	7-11 in 4-6 oz	7-11 in 4-6 oz
FULL LOAD	LINE PSI	7-11 in. 4-6 oz	7-11 in 4-6 oz

Notice the preceding tables give two (2) different units of measuring fuel pressure. The first is with a pressure gauge calibrated in ounces per square inch. The second and most accurate is the use of a simple water manometer. A manometer is calibrated in inches of water column.

**LP LIQUID WITHDRAWAL SYSTEMS**

When installing a unit equipped the LP liquid withdrawal a primary regulator is not required on the supply tank. The supply line is connected to a liquid withdrawal valve on the supply tank and runs directly to the fuellock strainer mounted on the engine generator set. Normally a 1/2 inch copper line is acceptable for this type of fuel installation. Be sure you use copper line certified for high pressure fuel. You must be sure that the valve you have connected to on the supply tank is in fact a liquid supply valve and has a drop tube inside the tank that is pulling fuel from the bottom of the supply tank. Before starting the unit you must confirm that you have a good liquid supply at the unit. **Engine generator sets equipped for liquid withdrawal will not run properly when supplied with high pressure vapor fuel.**

## LUBRICATION

Before starting the engine, check the oil level in the crankcase. If it is low, refill to the full mark with the proper weight/grade of oil as recommended by the engine manufacturer's maintenance instructions. The necessity of using the correct oil, and keeping the crankcase full cannot be over emphasized. Failure to use the proper oil and keep the crankcase properly filled will cause excessive engine wear and shorten its useful life.

## COOLANT

Before starting the engine, check the coolant level in the radiator. If it is low, refill as specified in the engine manufacturer's maintenance instructions. The radiator should be filled to about 1 inch below the filler neck. For additional information on engine coolant requirements see engine manufacturer's maintenance instructions.

## INSTALLING THE BATTERY

\*\*\*\* CAUTION \*\*\*\*

***In the following battery installation procedure, check to be sure the DGC-2020 is in the "stop" position. This should be your last step before initial start-up.***

Customer supplied twelve-volt batteries are required to complete the installation; 24 volt systems require 2 batteries. Installation of the highest CCA rated battery, within the correct BCI group, will increase cold weather starting performance. ***Gel batteries must not be used*** with the battery tender installed in the generator enclosure.

**These units require two 4D, 1200 CCA batteries for proper operation. The cranking system and engine control system on these units are 24 volt.** The engine does however have a true-tracker built into it that operates at 12 volts. This voltage is supplied by the engine wiring harness and not by the engine control on the set.

Installation and servicing of batteries must be performed or supervised only by personnel knowledgeable of batteries and the required precautions. Keep unauthorized personnel away from batteries.

When installing or replacing batteries, use the proper group/size **starting** battery. The battery should be a Maintenance Free lead acid design. Deep cycle batteries will **not work** for this application.

### CAUTION – PERSONAL DANGER

**CAUTION - NEVER** dispose of a battery in a fire. The battery is capable of exploding.

**CAUTION -DO NOT** open or mutilate the battery. Released electrolyte is known to be harmful to the skin and eyes and to be very toxic.

These engine generator sets are all **NEGATIVE** ground. Be very careful not to connect the battery in reverse polarity, as this may short circuit the battery charging system on the engine.

**CAUTION** – A battery presents a risk of electrical shock and high short circuit current. The following precautions must be observed when working with batteries:

1. Remove watches, rings and other metal objects.
2. Use tools with insulated handles.
3. Check both the battery cable ends and the battery posts to be sure they are free of corrosion.
3. Always connect the battery positive cable first and then connect the battery negative cable. When removing the battery cables from the battery reverse the procedure, disconnect the negative cable first and then the positive cable.
4. Be sure all connections are tight and coat the terminals and cable ends with dielectric grease.

**WARNING** – The electrolyte is a diluted sulfuric acid that is harmful to the skin and eyes. It is electrically conductive and corrosive. The following precautions must always be taken:

- \* Always wear full eye protection and protective clothing
- \* Where electrolyte contacts the skin, wash off immediately with water
- \* If electrolyte contacts the eyes, flush thoroughly and immediately with water and seek immediate medical attention
- \* Spilled electrolyte is to be washed down with an acid neutralizing agent. A common practice is to use a solution of one pound of bicarbonate of soda (baking soda) to one gallon of water. The bicarbonate of soda solution is to be added until the evidence of reaction, foaming, has ceased. The resulting liquid is to be flushed with water and the area dried.

### DANGER – Explosive Fire Risk

- \* Never smoke when near batteries
- \* Do not cause a flame or spark in the battery area
- \* Always discharge static electricity from your body before touching batteries by first touching a grounded metal surface

## SERVICING BATTERIES

Batteries used on these units may, over time, lose water. This is especially true if you are using a trickle charger to maintain your battery. When refilling the battery with water use only distilled water. Tap water will shorten the service life of the battery.

Never fill the battery above the fill line. Over filling above the upper level line may cause the electrolyte to overflow, resulting in corrosion to the engine or nearby parts. Immediately wash off any spilled electrolyte following the procedure above.

**NOTE: Always make sure that a new battery is fully charged before installing it on a generator set. Failure to do so can cause damage to the engine control module in the generator set.**

All connections must be clean and tight. Check the electrolyte (fluid) in the battery periodically to be sure it is above the plates. Never allow the battery to remain in a discharged condition.

## CONNECTING THE BATTERY CHARGER & BLOCKHEATER

A two-stage battery tender is provided for all standby generators. These battery chargers can vary depending on what model you have purchased and what the original specifications call for. For unit operating at 12 volts D.C. the standard charger is a battery tender that charges at a rate of 750 mA until the battery is fully charged and then automatically switches to a 13.2 VDC float charger. The charger has an indicator light on it, red indicates it is charging, and green indicates it is in the storage mode (float charge). This charger is mounted on the left hand side of the AC connection cabinet.

All 24 volt battery chargers and optional 12 volt chargers will have either a cord on them that you can plug into the receptacle on the side of the connection box or, depending on size, they may require hard wiring in the terminal block in the bottom of the connection box.

### \*\* NOTICE \*\*

***The trickle charger is not intended to recharge a battery which has become completely discharged. It is designed to produce just enough current to maintain a fully charged battery.***

The battery tender receptacle is to be powered by a GFCI circuit and installed in accordance with the United States National Electric Code. It is suggested that this circuit be fused for 20 -30 amps, depending on blockheater requirements. Then both the battery charger and the block heater can be connected to the same circuit. A 120 volt duplex receptacle is mounted on the customer connection box for a 20 amp circuits. Terminal blocks are provided for heavier circuits.

The engine blockheater installed on this unit should also be plugged in this receptacle. The block heater is thermostatically controlled and when plugged in will maintain the engine coolant temperature between 100 and 120 degrees F.

## MOUNTING THE AUTOMATIC TRANSFER SWITCH (A.T.S.)

\*\*\*\*\*

### \*\*\*\*\* WARNING \*\*\*\*\*

\*\*\*\*\*

***FIRE HAZARD - All wiring must be done by a licensed electrician, and must conform to the National Electrical Code and comply with all state and local codes and regulations. Check with the local authorities before proceeding!***

## INSTALLATION NOTES

Because of the many different types of service, feeder, and distribution equipment, no specific wiring instructions can be provided. It is recommended that only copper wire be used. In all cases it is essential that while the load is connected to the generator, there can be absolutely no feedback from the generator to the power line or the power line to the generator. When properly installed, the normal A.T.S. Control and safety systems will eliminate all paths for feedback.

To wire the automatic transfer switch into the existing wiring, first determine which circuits will be on the emergency load circuit. If

the entire load is to be transferred, the transfer switch can be wired in directly after the watt-hour meter and the service entrance, providing the service entrance ampere rating is within the transfer switch's rated capability.

If only specific circuits are to be powered under emergency power failure conditions, an additional distribution panel designated "emergency distribution panel" must be installed.

All selected emergency circuits are removed from main distribution panels and installed in the emergency distribution panel. The A.T.S. is then installed between the main panel and the emergency distribution panel. Suggested circuits: freezer, refrigerator, furnace, emergency lights, sump pump, emergency outlet circuits, etc. Total running load must not exceed generator rating.

## A.C. ELECTRICAL CONNECTIONS

**NOTICE - CLASS 1 WIRING METHODS ARE TO BE USED FOR ALL FIELD WIRING CONNECTIONS TO TERMINALS OF A CLASS 2 CIRCUIT**

**Note:** This symbol  always indicates ground where shown.

All wiring must be completed in accordance with the Nation Electric Code as well as any state or local codes.

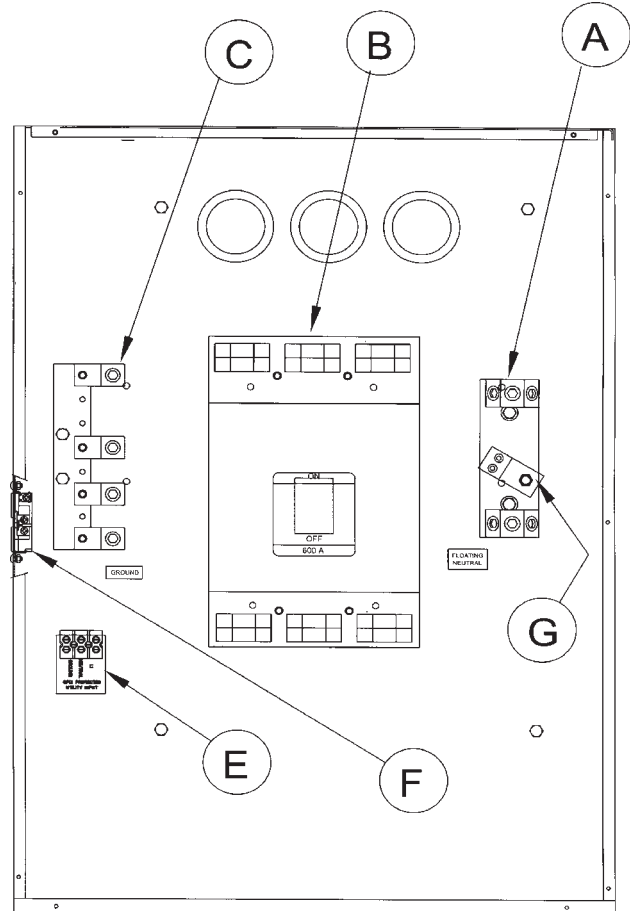



## CONNECTION BOX TERMINALS

Wire size requirements for each of the connections may vary but terminal lugs should be used for all connections. Torque spec for terminal lugs is 9.6 in. lbs.

### E - CUSTOMER REMOTE START CONNECTION TERMINALS -

The two remote start leads from the Automatic Transfer Switch are connected to the two terminals marked 1 & 23. The wire in terminal labeled #1 is Battery Negative and the wire in the terminal labeled #23 is your Remote Start lead. Closing these two leads together will signal the DGC-2020 to go into an auto-start mode and start up the engine generator.

Depending on the distance, 14 to 16 gauge stranded wire should be used. It is suggested that these wires be labeled S1 and S23. The terminal blocks are designed to use terminal lugs on all wires and the screws should be torqued to 9.6 in. lbs.

**Note:** Any relay closure can be used to start and stop this generator. As long as the contact stays closed the engine generator set will continue to run. Once the relay is opened the unit will shut down and remain in the standby mode until the remote start relay is closed again.

**F - ESTOP- & ESTOP+ - Remote Emergency Stop terminals.** These two terminals are shipped with a jumper installed. If your application requires the installation of a Remote Emergency Stop switch, remove the jumper and wire your switch to these terminals. **This unit will not start and run without either the jumper installed or a remote N/C switch installed.**

**G - FUEL SELECT JUMPER -** This connection allows you to change the engine from one fuel to the other. Without the jumper installed between "FUEL SELECT" & "GROUND" you are set to run on NG, with a jumper installed the engine is set to run on LP. See "Changing the Fuel Type" for additional information

### H - REMOTE DISPLAY PANEL INTERFACE TERMINALS -

These interface terminals are prewired to allow for the connection of a Basler RDP-110 remote display. This display allows for the remote annunciation of alarms at a location such as a nurses station or a control room. This display is used to meet the remote annunciation requirements of NFPA 110 standards.

#### NOTE:

**This feature must be turned on at the time the manufacture.**

When used with the RDP-110 two twisted pairs of 20 AWG wire may be used for distances of up to 4000 feet. The terminal blocks are designed to use terminal lugs on all wires and the screws should be torqued to 9.6 in. lbs.

## DC Interconnections to the Automatic Transfer Switch

Two control wires are required between the A.T.S. panel and the generator control terminal box. Depending on the distance, 14 to 16 gauge stranded wire should be used. These wires should be labeled S1 (ground) and S23 (start).

\*\*\*\*\*

#### \*\*\*\*\* WARNING \*\*\*\*\*

\*\*\*\*\*

**Be sure Engine Generator is in the "OFF" position before you make any DC interconnections.**

#### \*\*\*\*\*CAUTION\*\*\*\*\*

**Never run the AC and DC wiring in the same conduit.**

## Zenith ATS

The terminal markings in the Zenith ATS are marked "X1" and "X2". The wire labeled "Start 1" is routed to start contact "X1" and the wire labeled "Start 23" is routed to start contact "X2"

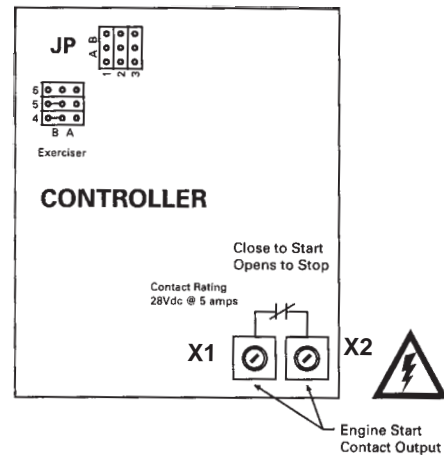

## ASCO 165 UL SWITCH

Your DC connection points in the ASCO 165 ATS are terminals "4" and "5 on the interface terminal block.

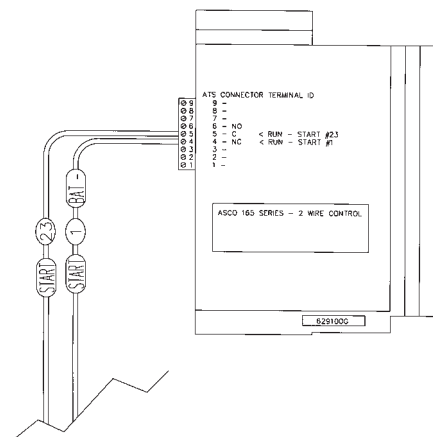

## ASCO 300 UL SWITCH

Your DC connection points in the ASCO 300 ATS are terminals "14" and "15". Depending on the size of the switch they are located in different locations.

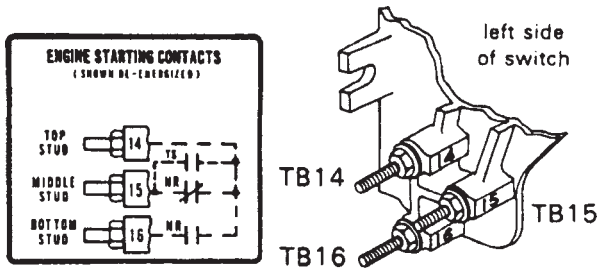
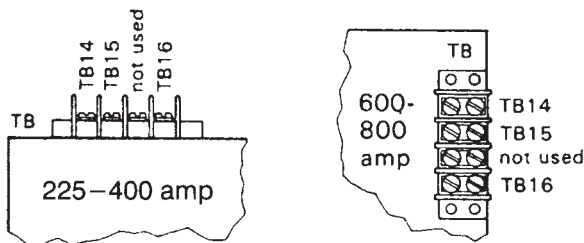

Figure 1-4. Engine starting contact label and location for 30 - 200 amp switches.



## INITIAL START UP

\*\*\*\*\*  
 \*\*\*\*\* **WARNING** \*\*\*\*\*  
 \*\*\*\*\*

**EQUIPMENT DAMAGE - DO NOT jump start these engine generator sets. Starting these units on a low battery or jump starting them will cause damage to the engine control module.**

Use the following check list to verify correct installation before starting the engine:

1. Engine oil. Fill as required with proper grade/qty.
2. Engine coolant. Fill as required with proper mixture.
3. Unit mounting base properly bolted down.
4. Clearance for service and maintenance on all sides.
5. Proper fuel line material and size.
6. All fuel line connections tight.
7. Battery connections clean and tight.
8. Battery fully charged.
9. All AC and DC wiring installed and properly protected.

After completing the above checklist, the engine-generator set is ready for the initial start-up test.

## PROCEDURE

Depress the "RUN" push-button on the front of the DGC. The engine-generator will crank and start automatically. If the engine fails to start, depress the "stop" push-button and correct the trouble before proceeding.

With the engine running smoothly check the no load voltage and frequency on the digital display. The voltage should be 208/240/480 AC depending on which model you have and a frequency of 59.5 To 60.5 hertz (Hz).

If you have the proper voltage at the generator the next step is to check the voltage at the generator terminals in the Automatic Transfer Switch. The voltage between the G1 and the G3 terminals should be the same as it was on the generator front panel. The voltage should also be checked between the hot terminals (G1 and G3) and the G-N to be certain of a balanced voltage output and a solid neutral connection. The voltage between G1 and G-N should be about 120 volts AC (277 on 480 units). The same approximate voltage should be found between terminals G3 and G-N (120 volts AC).

On three phase panels the G2 voltage level should also be checked. **ON 240 VOLT (DELTA) SYSTEMS BE SURE YOU KNOW WHERE THE HIGH VOLTAGE "WILD" LEG IS. IT MUST BE IN THE SAME LOCATION ON THE LINE SIDE AS IT IS ON THE GENERATOR SIDE.** (i.e. if it's on L-2 on the line side it must be on G-2 on the generator side.

### \*\* Notice \*\*

**If for any reason during the check out procedure the voltage and frequency are not correct, depress the "OFF" push-button and correct the trouble before proceeding.**

After verifying that the voltage and frequency are correct, depress the "OFF" push-button. The unit should shut off with no time delay. You are now ready to test the automatic start function.

To test the Automatic Transfer Switch follow the instruction in the operators manual you received with your transfer switch. If you get a fault light during the initial start up or prior to start up it is most likely a false warning light. Simply reset the A.T.S. and start over.

Once you have completed testing of the ATS, be sure you ALWAYS leave the system in standby mode unless servicing the unit. For standby operation, press the "AUTO" button on the front of the engine control. The green light should light up under the "AUTO" button.

## SETTING THE EXERCISER CIRCUIT

For all ATS's see the instruction manual shipped with the ATS for instruction on setting the exercise circuit in your ATS

# **TROUBLESHOOTING TABLES**

**Note: Before doing any troubleshooting, check the digital display on the DGC-2020. Normally it will tell why the unit has failed. This will shorten your troubleshooting time and in many cases prevent the replacement of parts that may not be defective.**

## **UNIT WILL NOT CRANK WHEN THE POWER FAILS.**

1. Digital Genset Controller not in "AUTO"
2. Transfer control switch not in "AUTOMATIC" position.
3. Incorrect wiring between transfer switch and generator.
4. Defective control relay in the transfer switch.
5. Fuse (s) blown in the Digital Genset Controller.
6. Defective Digital Genset Controller
7. Loose or dirty battery terminals.
8. Defective starter.
9. Defective start solenoid.
10. Dead Battery

## **ENGINE WILL NOT CRANK WITH GENERATOR RUN PUSH-BUTTON DEPRESSED.**

1. Battery dead.
2. Blown DC fuses on the Digital Genset Controller tripped.
3. Defective Digital Genset Controller.
4. Loose or dirty battery terminals.
5. Defective "Run/Auto" switch on generator.
6. Defective starter.
7. Defective start solenoid.
8. Locked up engine genset.

## **ENGINE CRANKS BUT WILL NOT START**

1. Improper fuel delivery to the unit.
2. Fuel supply shut off.
3. Fuel tank empty.
4. Air in the injection system.
5. Engine fuel rack has not opened.
6. Defective CANBus on the engine

## **ENGINE STARTS AND THEN STOPS AND ALARM LIGHT COMES ON**

1. Engine is low on oil.
2. Engine has high water temperature.
3. Engine has overspeed.
4. Engine has gone into overcrank.
5. No output from AC generator.
6. Loss of speed signal.
7. Loss of run signal.

## **ENGINE WILL NOT COME UP TO SPEED AFTER IT STARTS**

1. Insufficient fuel volume getting to the unit.
  - a. Too small of fuel line.
  - b. Fuel racks not opened properly
2. Governor is defective.
3. AC short in generator components.

## **ATS PANEL WILL NOT TRANSFER TO EMERGENCY SUPPLY (GENERATOR)**

1. No AC generator output from generator.
2. Defective ATS control board. See applicable transfer switch manual .
3. Circuit breaker between generator and transfer switch is either open or defective.

## **ATS PANEL WILL NOT RETRANSFER TO NORMAL POWER**

1. Proper normal line power not available at line terminals in ATS panel.
2. Defective ATS control board. See applicable transfer switch manual .

## **NO AC OUTPUT FROM GENERATOR**

1. Defective diode.
2. Defective voltage regulator.
3. Defective rotor.
4. Defective stator.
5. Defective exciter rotor.
6. Defective exciter stator.
7. AC short in the output leads.
8. Defective field circuit breaker.
9. Wiring error

# APPENDIX 1

**The table below is based on Table 310.16 in the National Electric Code 2008 Edition**

Allowable ampacities of insulated conductors rated 0 through 2000 volts, 75°C through 90°C. Not more than three current-carrying conductors in Raceway, Cable or Earth (Direct Buried). Adjusted for 40°C (104°F) ambient temperature.

Copper 75°C	Copper 90°C		Aluminum Copper Clad Aluminum 75°C	Aluminum Copper Clad Aluminum 90°C
Wire Type: RHW THHW, THW THWN, XHHW USE, ZW	Wire Type: TBS, SA, SIS FEP, FEPB, MI, RHH RHW-2, THHN THHW, THW-2 XHH, XHHW XHHW-2, ZW-2	SIZE AWG OR kcmil	Wire Type: RHW THHW, THW THWN, XHHW USE	Wire Type: TBS, SA, SIS, THHN THHW, THW-2 THWN-2, RHH RHW-2, USE-2 XHH, XHHW XHHW-2, ZW-2
44	50	8	35	41
57	68	6	44	55
75	86	4	57	68
88	100	3	66	77
101	118	2	79	91
114	137	1	88	105
132	155	1/0	106	123
154	177	2/0	119	137
176	205	3/0	136	159
202	237	4/0	158	187
224	264	250	180	209
251	291	300	202	232
273	319	350	220	255
295	346	400	238	278
334	391	500	273	319
370	432	600	299	350
405	473	700	330	382
418	487	750	339	396
431	505	800	348	410
458	532	900	374	437
480	560	1000	392	455
519	605	1250	427	496
550	642	1500	458	532
572	669	1750	480	560
585	683	2000	493	573

For additional information see table 310.16 of the National Electric Code



# THREE PHASE AC WIRING HIGH AND LOW WYE

**THREE PHASE-HIGH WYE  
277/480 VOLTS**

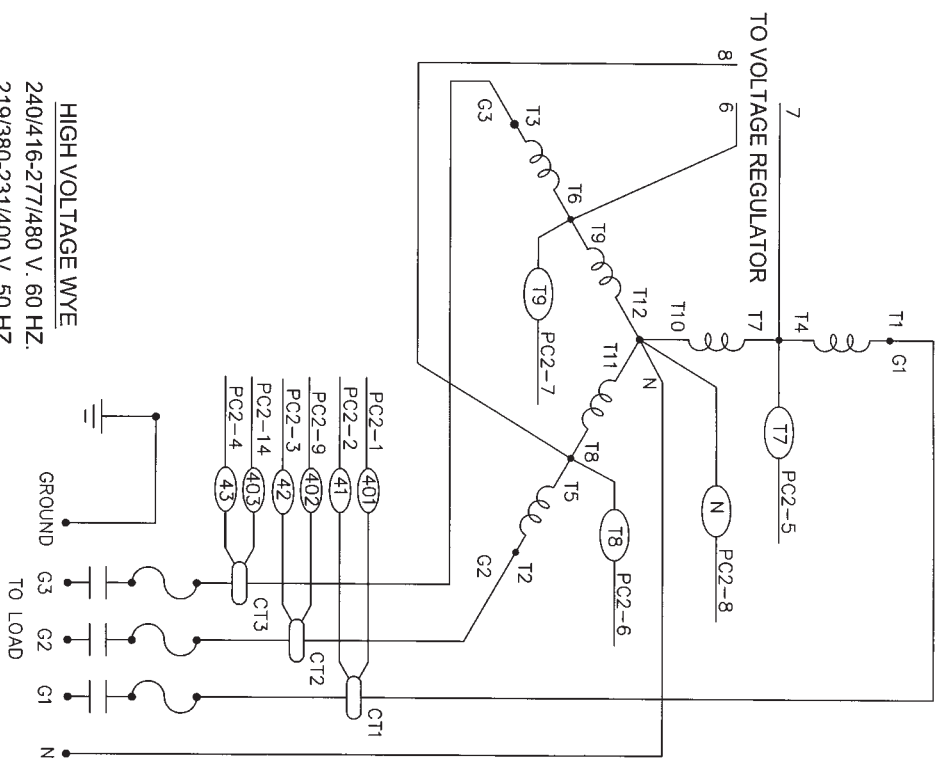

HIGH VOLTAGE WYE  
240/416-277/480 V. 60 HZ.  
219/380-231/400 V. 50 HZ.

**THREE PHASE-LOW WYE  
120/208 VOLTS**

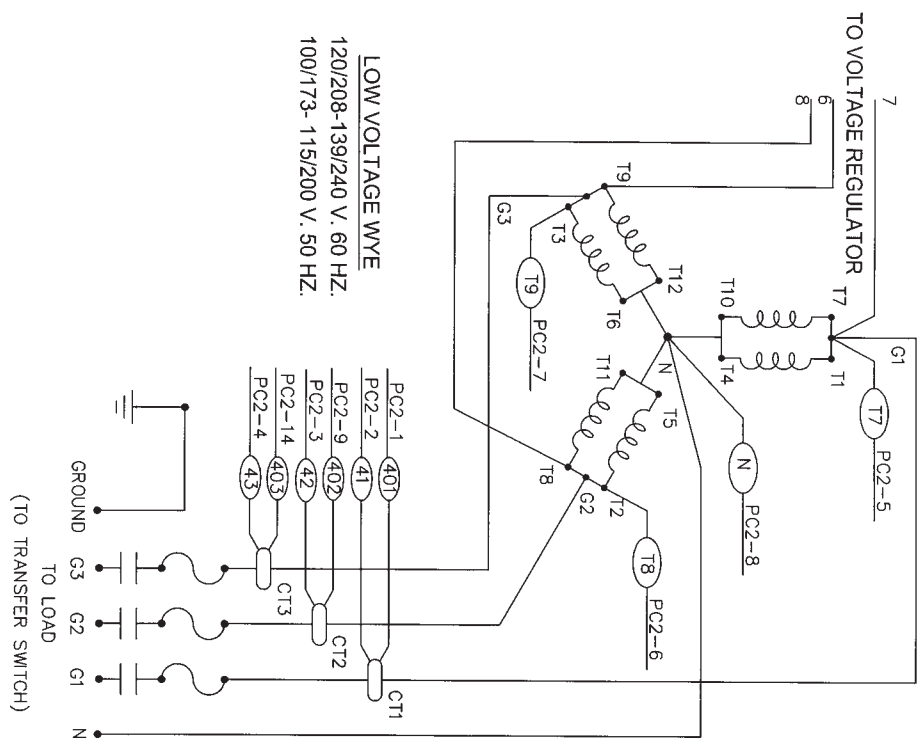

LOW VOLTAGE WYE  
120/208-139/240 V. 60 HZ.  
100/173- 115/200 V. 50 HZ.

(TO TRANSFER SWITCH)

# VOLTAGE REGULATOR WIRING THREE PHASE AND SINGLE PHASE

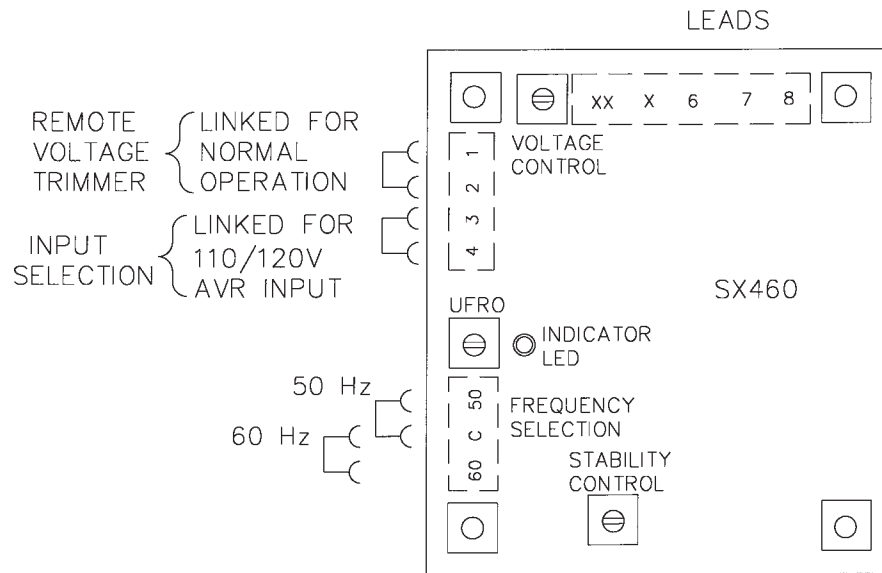

# DC SCHEMATIC

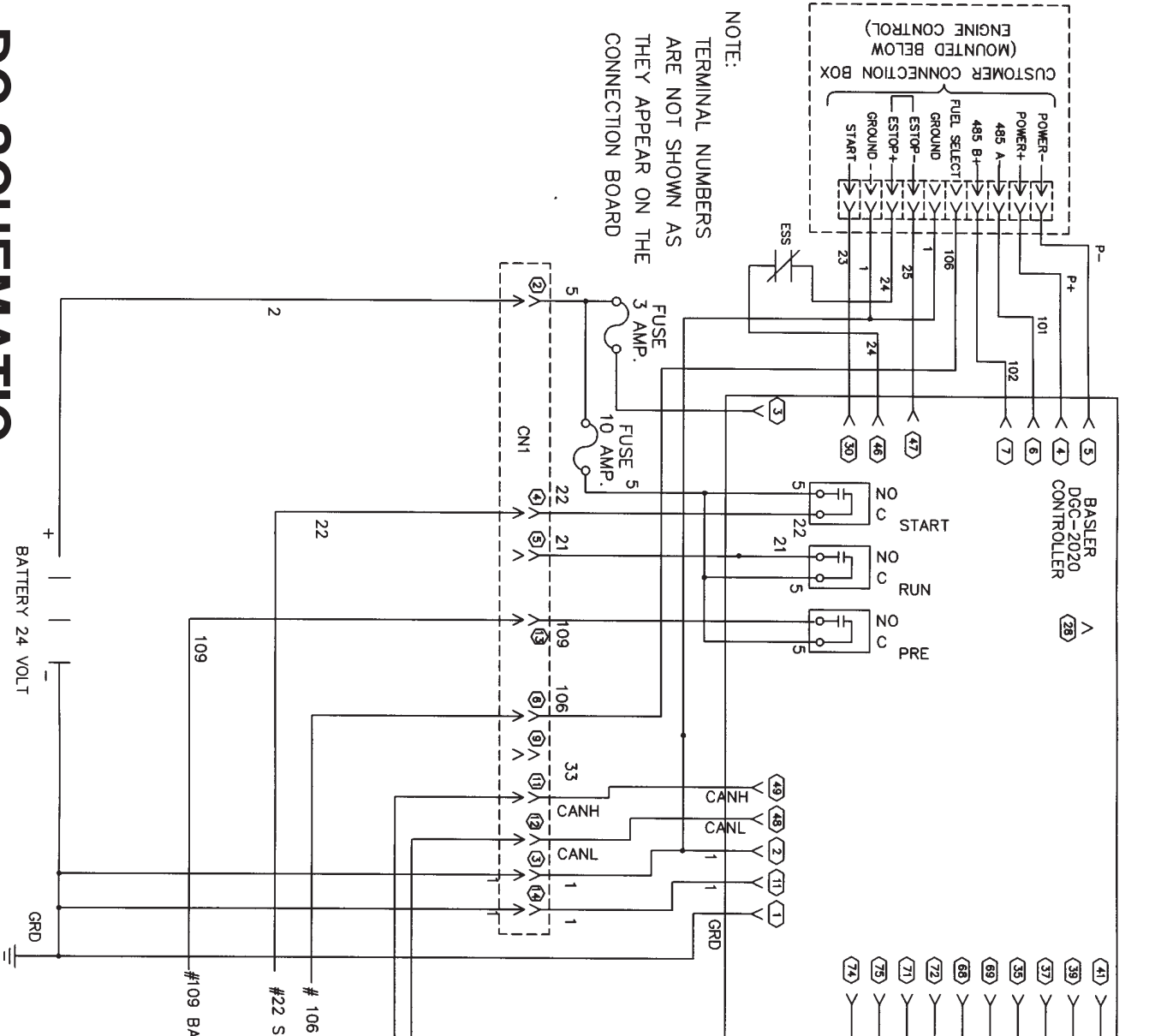

NOTE:  
 TERMINAL NUMBERS  
 ARE NOT SHOWN AS  
 THEY APPEAR ON THE  
 CONNECTION BOARD

## LEGEND

- CN1 16 PIN (LARGE CONNECTOR)  
ENGINE CONTROL HARNESS
- CN2 14 PIN GENERATOR HARNESS  
AC CONTROL HARNESS
- CANH CANBUS HIGH
- CANL CANBUS LOW
- ESS EMERGENCY STOP SWITCH
- GRD GROUND (CHASSIS OR FRAME)

Color	Function
S -	BLACK
R -	BROWN/WHITE
P -	BLUE/WHITE
N -	BLUE/PINK
M -	DK BLUE/YELLOW
L -	GRAY/DK BLUE
K -	DK BLUE/ORANGE
J -	DK BLUE/RED
H -	TAN/BROWN
G -	GREEN/YELLOW
F -	LT BLUE/PINK
E -	BROWN/PINK
D -	PINK/DK GREEN
C -	LT BLUE/WHITE
B -	WHITE/BLACK
A -	PINK/TAN

NOTE:  
 ALL OTHER ENGINE FUNCTIONS  
 ARE HANDLED BY THE ECU  
 ON THE ENGINE INCLUDING  
 THE FUEL SOLENOIDS.



## Limited Warranty

WINPOWER, Incorporated warrants to the original purchaser for 12 months or 1000 hours which ever occurs first, that goods manufactured or supplied by it will be free from defects in workmanship and material, provided such goods are installed, operated and maintained in accordance with WINPOWER written instructions.

WINPOWER's sole liability, and Purchaser's sole remedy for a failure under this warranty, shall be limited to the repair of the product. At WINPOWER's option, material found to be defective in material or workmanship under normal use and service will be repaired or replaced. For warranty service, return the product within 12 months or 1000 hours which ever occurs first from the date of purchase, transportation charges prepaid, to your nearest WINPOWER Authorized Service Center or to WINPOWER, Inc. at Le Center Minnesota.

THERE IS NO OTHER EXPRESS WARRANTY.

To the extent permitted by law, any and all warranties, including those of merchantability and fitness for a particular purpose, are limited to 12 months or 1000 hours which ever occurs first, from date of purchase. In no event is WINPOWER liable for incidental or consequential damages.

Note: Some states do not allow limitation on the duration of implied warranty and some states do not allow the exclusion or limitation of incidental or consequential damages, so the above limitations may not apply in every instance. This warranty gives you specific legal rights which may vary from state to state.

WINPOWER reserves the right to change or improve its products without incurring any obligations to make such changes or improvement on products purchased previously.

### EXCLUSIONS:

WINPOWER does not warrant Engines. Engines are covered exclusively by the warranties of their respective manufacturers, see enclosed warranties.

WINPOWER does not warrant Batteries, or Other Component Parts that are warranted by their respective manufacturers.

WINPOWER does not warrant modifications or alterations which were not made by WINPOWER, Inc.

WINPOWER does not warrant products which have been subjected to misuse and/or negligence or have been involved in an accident.

