

WINPOWER

OWNER'S INSTRUCTION MANUAL

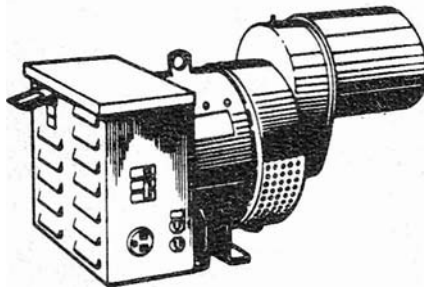

TRACTOR DRIVEN ALTERNATOR

**For Models:
30/20PTCD
30/20PTCM
50/30PTCD
50/30PTCM**

WINPOWER
GENERATOR DIVISION

WINPOWER
225 South Cordova Avenue
Le Center Minnesota 56057

CAUTION

FOLLOW THE INSTRUCTIONS IN THE OWNER'S MANUAL SPECIFICALLY WHEN PUTTING THIS ALTERNATOR INTO SERVICE.

IMPORTANT

ALL STANDBY POWER PLANTS INCLUDING TRACTOR DRIVEN ALTERNATORS SHOULD BE PERIODICALLY EXERCISED. FOR PROPER MAINTENANCE OF YOUR TRACTOR DRIVEN ALTERNATOR, IT SHOULD BE OPERATED FOR ONE HOUR CARRYING RATED LOAD AT LEAST TWICE A YEAR. THIS WILL ASSURE THAT YOUR ALTERNATOR IS IN OPERATING CONDITION AND READY FOR USE WHEN AN EMERGENCY CONDITION DEVELOPS.

PARTS LISTS, PARTS DRAWINGS, AND WIRING DIAGRAM PERTAINING TO YOUR UNIT ARE ENCLOSED WITH THIS MANUAL.

TRACTOR DRIVEN ALTERNATORS

INTRODUCTION

The words generator and alternator are used interchangeably but have the same meaning.

This manual covers standby generators driven by the power take-off of a farm tractor. These generators use a static excitation system which will be discussed in later paragraphs of this manual. All generators are carefully inspected, tested and packaged for shipment at the factory. The generator should be unpacked as early as possible upon receipt and inspected for damage which may have occurred during shipment. Any damage noted should be promptly reported to the carrier in order that a claim can be filed to recover the cost of the damage. If at all possible, this damage should be noted on the freight bill at the time of delivery. If the damage appears to be of a major nature, the generator should not be operated until the fault has been corrected.

Tractor driven generators are designed to deliver voltage and current similar to that of the normal power line. Equipment that can be operated on normal power can also be operated by the generator, provided that the capacity of the generator is not exceeded. It should be remembered that the power line, for all practical purposes, is backed by an unlimited generator.

When not in use the generator should be stored in a clean dry location. All types of mechanical equipment suffer from long periods of storage without use. The generator should be used at frequent intervals at some convenient time. By this procedure deterioration will be prevented and any possible fault will be noted before an emergency condition develops.

OPERATING THE ALTERNATOR

A double throw manual transfer switch must be used with a standby generator. The load, connected to the normal terminals of the transfer switch, is energized by the normal power line when the switch is in the normal position. The generator, connected to the emergency terminals of the switch, furnishes power when the switch is in the emergency mode position. When the normal power fails, the generator is attached to the tractor by means of the power take-off shaft.

Start the tractor and adjust the speed until the pointer of the voltmeter on the generator panel registers on the high side of the green portion of the color band.

Check the connected load to assure that all heavy electrical equipment is disconnected.

Move the transfer switch handle to the emergency position connecting the load to the generator.

Switch on all required electrical equipment within rated capacity of the generator maintaining tractor speed to cause the voltmeter to remain in the green portion of the color band.

If the circuit breaker of the generator control panel trips during operation, the connected load is greater than the rated generator capacity.

Reduce the load by disconnecting any non-essential equipment during emergency conditions.

After a short delay, indicating that the power restoration is not temporary, the transfer switch can be returned to the normal position and the tractor drive generator shut down.

After the load has been returned to normal power, normal precautionary measures should be made for protection of the tractor drive generator. If the generator is mounted on an off-highway trailer, such as the Winpower TD-M/73, it should be stored in a barn or machine shed in a dry and clean location. The generator should be covered with a tarpaulin to prevent the entrance of dust, chaff, and/or moisture. Generators installed in a permanent location should be mounted on a concrete base of at least 3" reinforced slab. Some provision should be made for a water and dust-tight cover to remain in place during standby conditions. A simple frame enclosure including doors for connecting to the power take-off and for ventilation is a very worthwhile provision. A typical weather protected installation is shown in Figure 1.

MAINTENANCE REQUIREMENTS

1. Maintain proper oil level in the PTO gear case. See the list attached for lubricants. Do not overfill, maintain level to the small pipe plug approximately four (4) inches from the bottom of the gear case on the gear case cover.
2. Make frequent inspection of the collector ring brushes. Brushes should move freely in the brush holders. When lifted from the surface of the collector ring by the brush shunt, and released, the brush should snap back in contact with the collector ring. Inspect brushes for wear. A brush that does not fill at least two-thirds of the brushholder should be replaced. Order brushes by the number on the parts list.
3. Inspect for loose or broken wiring connections. Make sure that wiring connections are not loosened at the brushholder.

4. Do not allow dirt or chaff to collect in the interior of the generator or the ventilation openings. Inspect for indication of the entrance of mice into the generator. The inlet and outlet openings are louvered, but possible damage to the louvers could occur. Mice can destroy the generator winding.

WHAT IS A STATIC EXCITED TYPE GENERATOR?

The word "static" means without motion; thus, the term "static excited" means that the excitation current for the field is supplied without the use of out-moded rotation type of excitation. Commutators and commutator brushes with the inherent problems of commutation and maintenance are not used.

In the WINPOWER static excited alternator, the alternating current output of the generator is rectified by means of a full-wave silicon diode bridge. Resulting direct current is used to supply the stationary field coils.

There is also a circuit in the alternator excitation system to maintain a relatively constant voltage as the load is varied.

The excitation circuit uses only one rectifier bridge. In this system the divided primary of the current transformer is connected in series with load lines. The secondary output of this transformer is then

connected to the shunt field and is also controlled by a reactor in series with one connection to the AC side of the bridge. The reactor serves to control the energy at no load, which reduces as load is added and also maintains stable voltage output by varying the field strength.

The use of the current transformer provides not only a means for variation of field strength for normal loading, but also provides a means for "forcing the field" during sudden momentary overloads such as are encountered in the starting of motors. By this means the intermittent capacity of the alternator can be increased to the higher rating indicated in the model designation.

PTO ALIGNMENT

Position the alternator in such a manner that the power take-off shaft is as near to direct line in all directions as possible. This will increase the life of the power take-off shaft, reduce wear on bearings of both the power take-off and the alternator, and reduce vibration. The maximum angle from a straight line should not exceed 10°. For the nominal power take-off shaft length of 42 inches, 10° is equal to 8 inch misalignment. For extended distance the maximum misalignment would increase 2 inches for each foot. For example: For a six (6) foot PTO shaft the maximum misalignment is twelve (12) inches from a straight line.

OPERATION OF TRACTOR DRIVEN ALTERNATORS

When the alternator is not in use it must be maintained in a clean and dry condition. The inside of the panel, frame and air inlet and outlet must be free from dirt and chaff.

When connection is made at the meter pole, a

double throw manual transfer switch must be used. Normal power is connected to the top, the load at the center, and the alternator at the bottom of the switch. Warranty is void if a transfer switch is not used (check instruction manual on transfer switch.)

PROCEDURE FOR USE

1. Set the main circuit breaker on the alternator panel to "off."
2. Connect the power take-off shaft securely to the alternator and the tractor. Position as near to a straight line as possible.
3. Adjust power take-off speed to maximum then back down to maintain the voltage indicator in the green portion of the color band.
4. Place plug in receptacle. Place transfer switch in the emergency position.
5. Place the load circuit breaker in the "on" position. If the breaker trips, check for short circuit or grounded connection in the load cable to the double throw switch. A breaker that trips from overload or short circuit must be reset by moving to "off" before reclosing.
6. Keep meter in the green by adjusting tractor speed.
7. The return of normal power will be indicated by the lamp on the front of transfer switch; applicable only when the transfer switch is equipped with indicating lamps. After sufficient time to assure that power restoration isn't temporary, return the transfer switch to normal power.
8. Place the alternator circuit breaker in "off" position. Do not remove plug before opening the breaker.
9. Slowly reduce power take-off speed to a minimum and disengage the power take-off. Some tractors have a brake on the power take-off which stops the shaft instantly. **Stopping the alternator rotor instantly from rated speed may result in a broken shaft.**
10. Exercise PTO alternator for one hour carry rated load at least twice a year.

SERVICE DIAGNOSIS

LOW OUTPUT VOLTAGE

POSSIBLE CAUSE	REMEDY
Low Speed	<ol style="list-style-type: none">1. Check for overload on the engine or tractor.2. Defective governor. Check governor spring tensions, tight or defective throttle levers and joints.3. Defective engine (see engine check list).
High line loss. Indicated by lower voltage at load than at generator terminals.	Increase size of line wiring. Might also be the result of loose connection which will be indicated by excessive heating at the loose connections.
Shorted or grounded field coil. In some cases one coil only, that is shorted or grounded, will reduce voltage to approximately one-half of rating.	See information for testing field circuits.

HIGH OUTPUT VOLTAGE

Excessive Speed	Check governor linkage, spring tensions, etc. Governor linkage must be free from dirt and gum.
-----------------	--

EXCESSIVE HEATING

Clogged ventilating inlet and/or outlet.	Clean screens, make sure interior of generator is unobstructed.
--	---

NO OUTPUT VOLTAGE

Poor brush contact: Brushes tight in holder.	Clean brushholder. Brush should move freely in holder.
Weak brush spring tension	Brush spring tension should snap brush into contact with ring when lifted and released.
Film on collector rings caused by corrosive or dirty atmosphere.	Clean rings with fine sandpaper during rotation of armature. Caution: Tape sandpaper to stiff cardboard for safety.
Defective rectifier bridge (see method of checking bridge)	Replace defective bridge assembly. Find assembly number under rectifier assembly in parts list.
Open field circuit (see illustration for method for checking, page 5)	Replace open coil(s) or repair if open connection is in the connecting leads.
Grounded or shorted field coil(s) (see illustration for method, page 5)	Replace grounded coil(s) and insulation or repair damage.
Loss of residual magnetism. This is a condition brought about by some unusual condition. It will usually occur after disassembly of the field frame.	See note under field assembly for procedure to restore magnetism, page 5.

DEFECTIVE ARMATURE

Shorted winding. This can be identified by the use of a "growler" at a competent re-winding shop.	Replace or rewind the armature. (Include generator model and serial number on the order.)
Grounded armature. Check winding by test lamp or high potential tester from collector rings to shaft.	Same as above
Open armature circuit. Measure circuit between rings with an ohmmeter. Should have a circuit between any pair of rings.	Same as above

VOLTAGE UNSTEADY

Loose connection, probably at rectifier	Tighten with pliers.
---	----------------------

SLOW VOLTAGE BUILDUP

Slow voltage buildup, or no voltage buildup, unless load is applied.	See below.
Excessive air gap between armature and field poles.	Shim all poles. Establish .007" air gap.
Not enough air gap in choke.	Remove top of choke and install thickness of this paper until voltage builds up in 3 to 5 seconds to 260 Volt no load on 120/240 Volt unit. Replace top of choke and tighten the bolt. Loose bolts will cause chatter and unstable voltage.

Testing of Rectifier Assembly.

Remove the lead from the positive (+) terminal and one of the leads going to A.C. terminal of the bridge.

- I. Connect black lead of meter to positive (+) terminal of bridge and red lead to one of the A.C. terminals of bridge. Meter should read about 20 Ohm.
- II. Now, reverse the lead on bridge terminals. Meter should read open circuit or infinite resistance.
- III. Connect black lead of meter to (+) terminal and red lead to other A.C. terminal of bridge. Meter should read about 20 Ohm.
- IV. Now reverse the leads on bridge terminals. Meter should read open circuit or infinite resistance.
- V. Connect red lead of meter to (-) terminal of bridge and black lead to one of the A.C. terminals of the bridge. Meter should read about 20 Ohm.
- VI. Reverse the leads and you should read infinite resistance.
- VII. Connect red lead of meter to (-) terminal of the bridge and black lead of meter to other A.C. terminal of the bridge. Meter should read about 20 Ohm.
- VIII. Now reverse the leads and you should observe infinite reading on your meter.

All eight steps are described for a good bridge.

A shorted diode will give zero resistance reading in both directions.

A low resistance reading of 2 Ohms or so will show leakage current and diode should be replaced.

An open diode will give a high resistance (infinite) reading in both directions.

Handling Procedures for Rectifiers (Diodes and Bridge Assemblies)

1. Rectifiers should be handled in a manner which avoids the possibility of sudden shocks being applied, such as those encountered in dropping from a work bench to a hard floor. Damage done to the rectifier by such shocks may not be detected by subsequent testing, yet may cause poor system reliability.

2. Any lead trimming or forming operations should be done with care to avoid damaging the leads or the glass header seals.
3. Leads should never be bent or twisted. If lead forming is necessary the lead should be supported so that no bending occurs closer than $\frac{1}{8}$ inch to the rectifier body, and that header seals are not fractured or broken. If this seal is broken, it removes mechanical support for the lead and allows entry of moisture into the rectifier, almost assuring early failure.
4. Care must be taken during all soldering operations. It is unsafe to exceed the general specification to which diodes are tested for solder ability. This is 10 ± 2 seconds at a temperature of $230^{\circ}\text{C} + 5^{\circ}\text{C}$ at a point $\frac{1}{16} \pm \frac{1}{32}$ inch from the diode body. This is not as restrictive as it may sound, since 230°C is 446°F and 60/40 solder melts at 375°F , and with proper procedure and soldering tools a solder joint can be made in 4 to 7 seconds. Also, solder joints are almost never made this close to the diode body. Heat sinks, such as a pair of needle nose pliers or alligator clips, can be attached to the lead between the solder joint and the diode body to further reduce the possibility of heat damage. Also, precautions should be taken to prevent solder or flux bridging which causes a conductive path across the case of the rectifiers. As a precaution all flux should be removed by using alcohol and a small brush. Pay particular attention to assure that glass header seals are free of all flux.

Sticky Brushes

Brushes must move freely in the brushholders to maintain contact to the slip rings. The field circuit begins at the brushholders. If the brush does not maintain contact to the ring, or if a film has developed on the ring from lack of use and maintenance, there will be no current in the field coils; consequently, the field strength will not increase from the low residual value resulting in lack of voltage buildup. The cause in both cases is usually lack of maintenance and improper storage.

Build Up of the Excitation Field

Occasionally an alternator will seem to be defective as there is no indication on the voltmeter on start up. This will sometimes be caused by a too careful increase in power take-off speed. Rated speed isn't actually reached. The better procedure is to adjust to maximum, then back down to maintain the indication in the "green" portion of the color band.

When repairs have been made or the alternator has not been used for a long period it may be necessary to "flash the field." An inexpensive tool using a small step-down transformer is the best means for this purpose. It has a nominal input of 125 volts, 25 volts secondary and 2 ampere rating. Avoid the use of a variable transformer. Reversal of power line and alternator ground may cause damage. Winpower Part No. EE-376 can be suitable for this purpose.

With the alternator operating, plug the transformer into a wall outlet and insert the prods into the 125 volt outlet on the alternator panel. Remove at once when an indication is shown on the voltmeter.

Field Check of Armatures (Tractor Drives)

1. Instrument required—Volt-Ohmmeter. Set on Ohm X1 scale.
2. Check Ohmmeter by touching leads together. Reading should be zero.
3. Lift all brushes from armature that is to be checked.
4. **First**, check to find out if armature windings are grounded (most probable).
 - a. Connect one lead of Ohmmeter to ground.
 - b. Touch other lead to each ring. Meter should stay at infinite (not move).
 - c. If reading is indicated, armature is grounded and should be replaced.
 - d. If armature has commutator, it should not indicate ground.
5. **Second**, check to find out if **armature windings are open**.

Symptom: when generator was running, no voltage on one line to neutral; or on 115V unit, no voltage. Lift all brushes.

- a. **Armature 3 Rings, 1 \emptyset or 3 \emptyset , 3 Wire**
Connect one ohmmeter lead to Ring 1. Touch other lead to Ring 2. Meter should read Zero or very low. Then touch lead to Ring 3. Meter should read Zero. Winding is open if reading is infinite.
- b. **Armature 4 Rings, 3 \emptyset , 4 Wire**
Connect one ohmmeter lead to Ring 1
Touch other lead to Ring 2 Reading should be near zero
Touch other lead to Ring 3 Reading should be near zero
Touch other lead to Ring 4 Reading should be near zero

c. Armature 4 Rings, 1 \emptyset

This armature has two windings

One starting on Ring 1 Ending on Ring 2

One starting on Ring 3 Ending on Ring 4

Connect ohmmeter one lead to Ring 1

Other lead to Ring 2 Meter should read near zero

Other lead to Ring 3 Meter should read infinite

Other lead to Ring 4 Meter should read infinite

Connect one lead to Ring 3

Other lead to Ring 4 Meter should read near zero

Other lead to Ring 1 Meter should read infinite

Other lead to Ring 2 Meter should read infinite

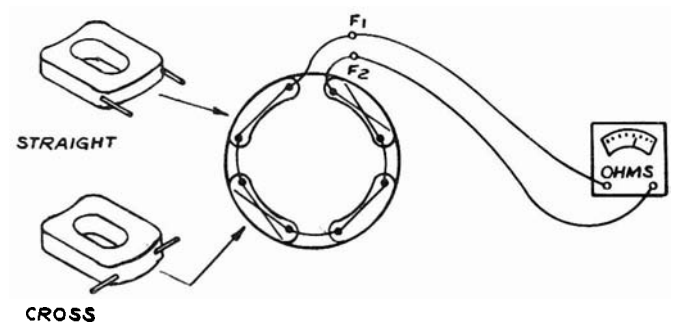

NOTE: Fields alternate "straight" and "crossed" to provide proper polarity: When ordering replacement coils be sure to include Model, Type, and Serial Number.

Testing a Field Circuit

Disconnect field leads F₁ and F₂

Measure resistance of entire field circuit as shown in Figure 2. A resistance of less than the range shown on the table indicates a shorted coil. The defective coil can be identified by measuring the resistance of the individual coils. A coil with an appreciable lower resistance has shorted turns.

A reading of no deflection or very little deflection of the meter pointer indicates a defective coil or broken interconnection. Inspect all interconnecting wires for tight and un-corroded connection. Each coil should measure approximately 1/4 of the total specified resistance. A very high resistance indicates broken internal wires.

A grounded field can be identified by connecting one ohmmeter lead to one field lead and touching the other to an unpainted spot on the field ring. Make sure that none of the coil leads are in contact with the ring. A grounded field can usually be corrected by repairing the insulation once the grounded point or points are located.

NOTE: Whenever the field coils have been removed and/or replaced, the field must be re-energized.

TRACTOR DRIVE WINDING RESISTANCES

ROTATING ARMATURE TRACTOR DRIVE

MODEL	(COLD) RESISTANCE (OHMS)					
	FIELDS		ARMATURE			
	F1-F2	S1-S2	Ring 1&2	Ring 1&3	Ring 2&3	Ring 1&4
15/10PTCD	27/Coil 54/Set	.015/Coil .061/Set	.14, (Ring 3&4 = .13 Ohm)			
25/15PTCD & M	6.3/Coil 25/Set	2.4/Coil 9.5/Set	.065	.063	.125	
25/15PTJD & M	1.75/Coil 7/Set		.11	.15	.22	.25
30/20PTCD & M	2.5/Coil 10.2/Set		.11	.12	.20	
30/20PTJD & M	1.44/Coil 5.76/Set		.064	.064	.11	.145
45/25PTCD & M	2.1/Coil 8.4/Set		.039	.034	.065	
45/25PTJD & M	2.1/Coil 8.4/Set		.062	.06	.09	.11
50/30PTCD & M	2.1/Coil 8.5/Set		.031	.031	.062	
50/30PTJD & M	1.64/Coil 6.54/Set		.05	.05	.08	.10
80/40PTJD & M	2.3/Coil 2.3/Set		.040	.041	.056	.065
80/50PTCD & M	2.3/Coil 2.3/Set		.035	.025	.041	

REVOLVING FIELD TRACTOR DRIVE

MODEL	(COLD) RESISTANCE (OHMS)	
	FIELD	ARMATURE
100/60PT ()	2.2 Total	.019 T7 to T10, etc. (resistance per leg)

REVOLVING FIELD TRACTOR DRIVE WITH EXCITER

MODEL	(COLD) RESISTANCE (OHMS)			
	EXCITER		MAIN GENERATOR	
	FIELD	ARMATURE	FIELD	ARMATURE
150/100PT ()	55 Total	.23	5.2 Total	.0105 T1 to T4, etc.

LUBRICANT CROSS REFERENCE CHART

(For Chain Driven Units)

MANUFACTURER	DESCRIPTION
Alemite	HD Gear Oil No. 3
Allube (Far-Best Corp.)	Moly-Shield IGO 80
American Lubricants Co. (Alubco)	Alubco Moly Ultra-Tec Lube, SAE 80
Amoco Oil Co. (Standard Oil Co. of Indiana)	Amogear EP1
Ashland Oil & Ref. Co.	EP Compound No. 30
Atlantic-Richfield Co.	Pennant NL S-315
Bel-Ray Co., Inc.	Bel-Ray 100 Gear Oil #50
Boron Oil Co.	Gearep 80
Brooks Oil Co.	Brooks L-40
Cato Oil and Grease Co., Inc.	Universal 2105 Gear Lub 80
Champlin Petroleum Co.	MGX #3
Chevron Oil Co. (Standard Oil Co. of California)	Chevron NL Gear Compound 68
Cities Service Oil Co.	Citgo EP Compound 55
Continental Oil Co.	Milgear L50
DuBois Chemicals	MPO-30
Exxon Co., U.S.A.	Spartan EP68
Fiske Refining Company	APG 80
Georgia-Carolina Co.	G-C Yukol E.P. #80
Gulf Oil Corp.	E.P. Lubricant 55
Imperial Oil & Grease Co.	Molub-Alloy 804
Kendall Refining Co.	Kendall NS-MP SAE 80 W
Mobil Oil Co.	Mobilgear 626
National Refining Co.	EP Compound No. 30
Parr Inc.	1022
Pennwalt Corp (Keystone Div.)	WG 5X
Pennzoil Co.	Maxol EP #1 or MP4080
Phillips Petroleum Co.	Philube 1LB Gear Oil EP-3
Shell Oil Co.	OMALA 33
Standard Oil Co. (Ohio)	Gearep 80
Stewart-Warner Corp.	HD Gear Oil No. 3
Sun Oil Co.	Sunep 1050
Texaco	Meropa 68
Tower Oil & Technology Co.	Express Gear Lube EF
Valvoline Oil Company	EP Compound No. 30
White & Bagley Co.	Oilzum Super Gear Oil SAE 80 EP
Union Oil Co. of California Western Region Eastern Region	Union PB Gear Lube 50 Union Ext. Duty NL 50
United Refining Co.	Emblem APG Lube ZEP (80)
West Penn Oil Co., Inc.	W/P Hi-Gear Compound No. 1

PARTS LIST FOR MODELS 30/20PTCD – 30/20PTCM – 50/30PTCD – 50/30PTCM

REF.	DESCRIPTION	PART NO.	REQ'D	Model			
				30/20PTCD	30/20PTCM	50/30PTCD	50/30PTCM
1	Panel Front	G-7231	1	x	x	x	x
2	Panel Back Assembly	G-5434-38	1	x	x		
		G-5434-43	1			x	x
3	Bearing Retainer	W-43	1	x	x	x	x
4	Field Frame Assembly	G-4776-17	1	x	x		
		G-5432-21	1			x	x
5	Field Frame	G-7286	1	x	x		
		G-6362	1			x	x
6	Brush Gear Assembly	G-5430-1	1	x	x	x	x
7	Tinnerman	4996	6	x	x	x	x
8	Brush	Y-51	9	x	x	x	x
9	Brush Spring	G-3422	9	x	x	x	x
10	Bearing-Slip Ring End	D-8	1	x	x	x	x
11	Not Applicable						
12	Armature	G-7295-1	1	x	x		
		G-7452-13	1			x	x
13	Fan Assembly	G-5878-1	1	x	x	x	x
14	Washer	S-7019	1	x	x	x	x
15	Bearing - DE	D-3	1	x	x	x	x
16	Grease Seal	TE-888	1	x	x	x	x
17	Sprocket - Lower	S-6350-1	1	x			
	- 3 row	S-6779-2	1		x		
	- 4 row	S-9630	1			x	
	- 3 row	S-9631	1				x
18	Washer	1211	1	x	x	x	x
19	Screw	11508	1	x	x	x	x
20	Key - Sprocket	S-7467-12	1	x	x	x	x
21	Key - Fan	S-2056-90	1	x	x	x	x
22	Not Applicable						
23	Coil Shield	J-528-2	8	x	x		
		J-635	8			x	x
24	Field Pole	G-7287	4	x	x		
		G-5037-1	4			x	x
25	Field Coil	H-1094	4			x	x
25a	Field Coil	H-1232-1	1	x	x		
25b	Field Coil	H-1232-2	1	x	x		
25c	Field Coil	H-1232-3	1	x	x		
25d	Field Coil	H-1232-4	1	x	x		
26	Panel Top Cover	S-7623-2	1	x	x	x	x
27	Wrapper	S-7037	1	x	x	x	x
28	Gear Case Housing Assy.	G-5922	1	x	x	x	x
29	Housing	I-885	1	x	x	x	x
30	Bearing Cup	D-27	1	x	x	x	x
31	Drive Shaft Assembly	G-5925	1	x			
		G-5925-1	1			x	
		G-5964	1			x	x
32	Bearing Cone	D-28	1	x	x	x	x
33	Sprocket - 4 row	S-7300	1			x	
	- 3 row	S-7301	1	x			
	- 3 row	S-6778-1	1			x	
34	Shaft 6 Spline 1 3/8	N-593	1	x			
		N-593-4	1			x	
		N-593-3	1			x	x

REF.	DESCRIPTION	PART NO.	REQ'D	Model			
				30/20PTCD	30/20PTCM	50/30PTCD	50/30PTCM
35	Bearing Cone	D-70	1	x	x	x	x
36	Gasket	X-197	1	x	x	x	x
37	Bearing Cup	D-71	1	x	x	x	x
38	Gear Case Cover	I-884	1	x	x	x	x
39	Gear Case Cover Assy.	G-5924	1	x	x	x	x
40	Shim .001 Thick Amber	X-198-1		x	x	x	x
a	Shim .002 Thick Red	X-198-2		x	x	x	x
b	Shim .005 Thick Blue	X-198-3		x	x	x	x
c	Shim .010 Thick Brown	X-198-4		x	x	x	x
d	Shim .020 Thick Yellow	X-198-5		x	x	x	x
41	Retainer Plate	I-883	1	x	x	x	x
42	Seal - Upper	X-201	1	x	x	x	x
43	PTO Guard	S-7606	1	x	x	x	x
44	Washer - Hardened	S-7046	1	x	x	x	x
45	Key	S-2056-86	1	x	x	x	x
46	Drive Chain - 3 row	G-7283	1	x			
	- 4 row	G-7467	1			x	
	- 3 row	G-4333	1			x	x
47	Vent Cap	10801	1	x	x	x	x
	ENGR. PARTS LIST PL-2038			x	x		
	ENGR. PARTS LIST PL-2201					x	x
	PARTS DRAWING IE-9670			x	x	x	x
	WIRING DIAGRAM IC-6949			x	x		
	WIRING DIAGRAM IC-6988					x	x

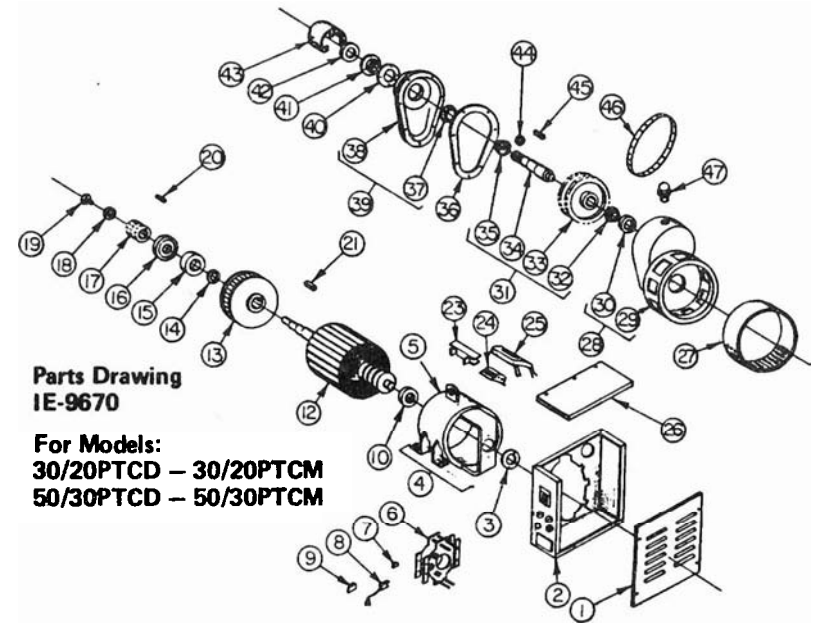

PANEL PARTS LIST

REF.	DESCRIPTION	PART NO.	REQ'D	G-5434-38 (30/20 Models)	G-5434-43 (50/30 Models)
Panel G-5434-38 (30/20PTCD & 30/20PTCM)					
Panel G-5434-43 (50/30PTCD & 50/30PTCM)					
1	Choke	EE-2056	1		x
		EE-2295	1	x	x
2	Receptacle 250 volt	EE-399	1	x	x
3	Receptacle Duplex	EE-323	1	x	x
4	Circuit Breaker 50 Amp	EE-2809-8	1	x	x
5	Circuit Breaker 15 Amp	EE-2813-1	1	x	x
6	Mounting Plate	S-5027-1	1	x	x
7	Capacitor	EE-1539	1	x	
7	Not Applicable				x
8	Rectifier Assembly Shunt	EE-2214	1	x	x
9	Voltmeter	VM-71	1	x	x
10	Panel Weld Assembly	G-5838-30	1	x	x
11	Insulator	W-203	2	x	x
12	Mounting Plate	S-5027-1	1	x	x
13	Filler Plate	EE-779	1	x	x
14	Circuit Breaker	EE-2809-12	1	x	x
		EE-2809-14	1		x
15	Ground Lug	EE-1671	1	x	x
16	Tinnerman	4957	7	x	x
17	Transformer	EE-2047	1	x	
		EE-2059	1		x
18	Load Plug Bracket	S-9292	1	x	x
19	2 Pole Load Plug Housing	EE-2327	1	x	x
20	Load Plug Terminal	EE-2328	4	x	x
21	Contact Bushing #4 wire	EE-2330-3	3	x	x
		#6 wire	EE-2330-6	3	x
ENGR. PARTS LIST PL-2038				x	
ENGR. PARTS LIST PL-2201					x
PANEL PARTS DRAWING IE-10951				x	x

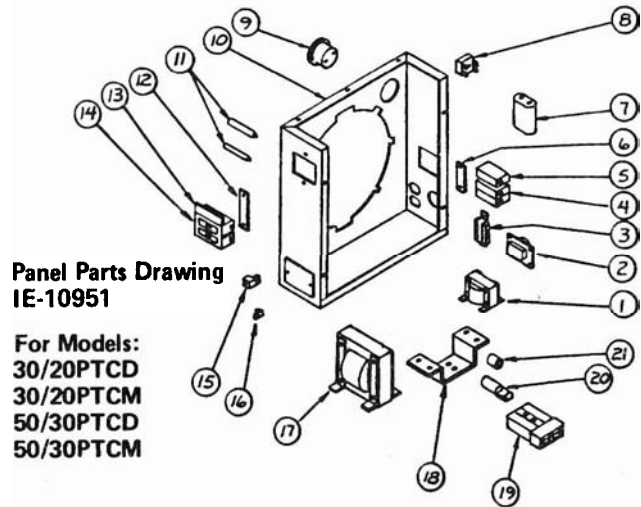

WIRING DIAGRAM IC-6949 FOR 30/20PTCD & 30/20PTCM

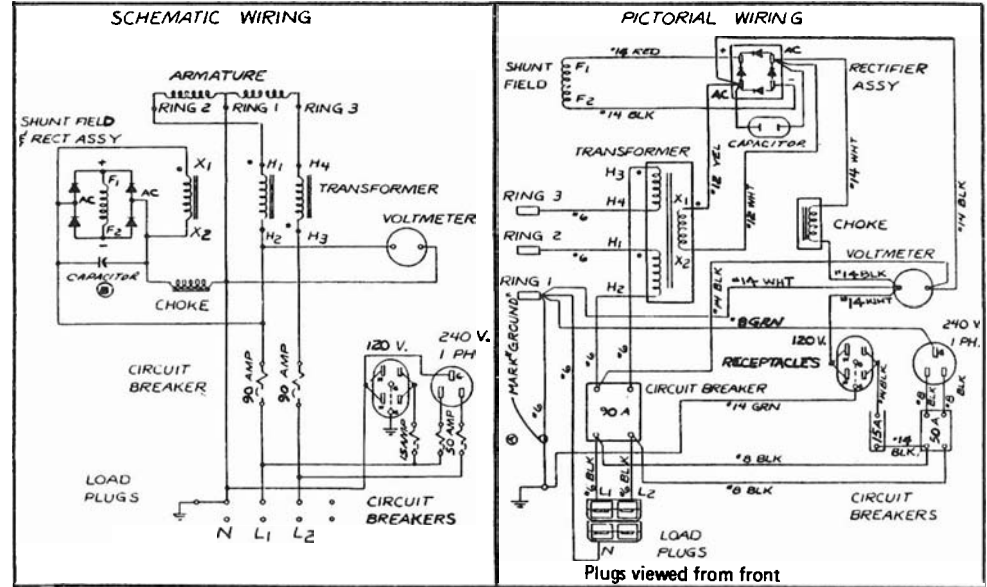

WIRING DIAGRAM IC-6988 FOR 50/30PTCD & 50/30PTCM

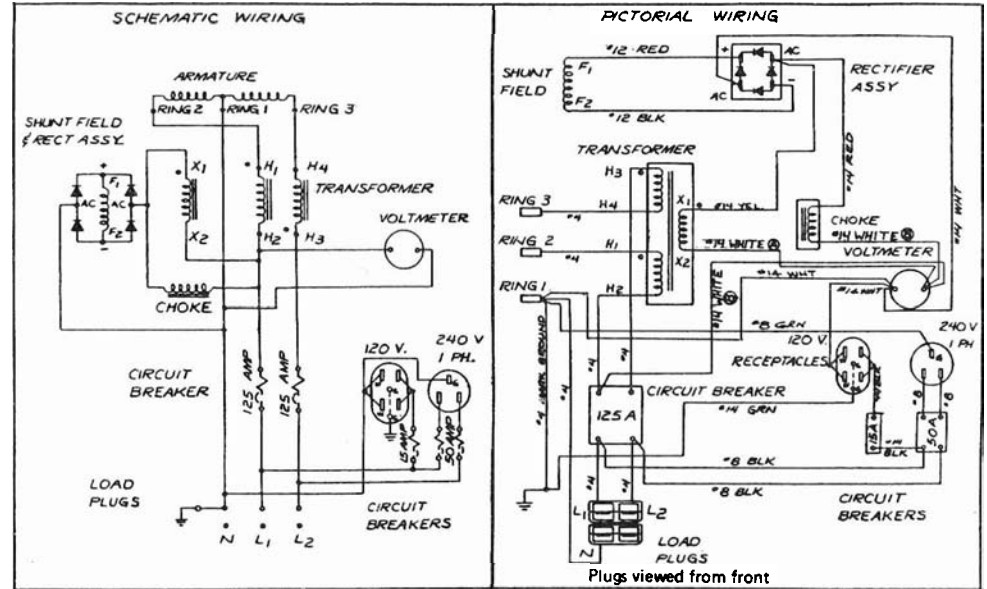

**SUGGESTED WEATHER PROTECTION
FOR METERPOLE INSTALLATION**

IMPORTANT: For trouble free operation,
exercise your alternator at
least twice a year.

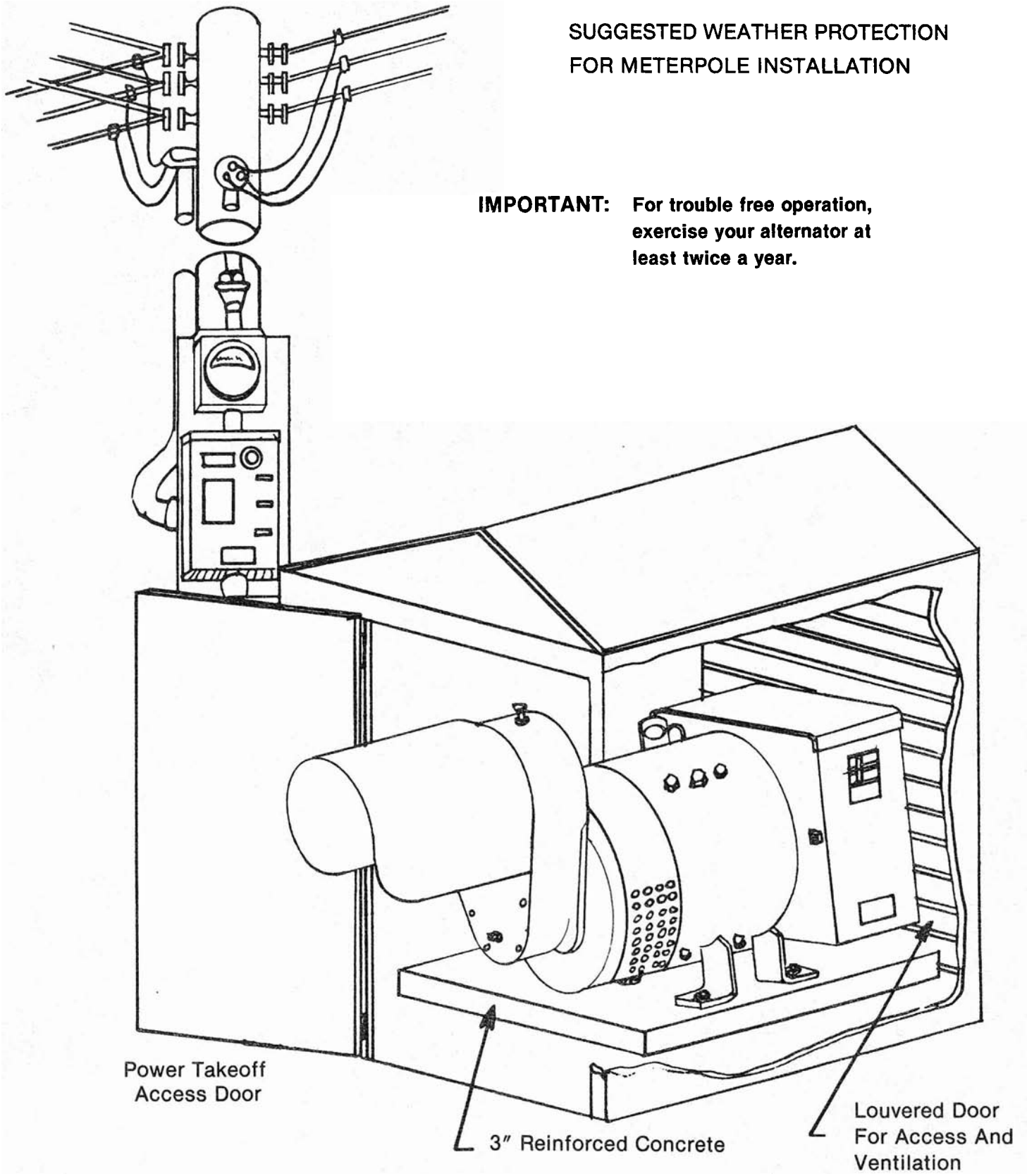

WINPOWER

THREE YEAR

P.T.O. DRIVEN ALTERNATOR LIMITED WARRANTY

Winpower Inc. hereinafter referred to as Winpower, warrants for a period of three years to the original user that each Winpower PTO driven alternator is free from defects in material and factory workmanship if properly installed, serviced and operated under normal conditions according to Winpower's published instructions.

Manufacturer's obligation under this warranty is limited to correcting without any labor or material charge to the user for the first year of the said three years at its factory, or at its authorized repair centers, any part or parts which shall be returned and which upon examination shall disclose to Winpower's satisfaction to have been originally defective in material or in workmanship.

After one year and for a subsequent period of two years Winpower will warranty the cost of parts. The cost of labor involved in repairing or replacing parts will be borne by the user. Winpower shall not be liable for any incidental and consequential damage.

All transportation charges on parts or units submitted for replacement or repair to the factory or authorized repair centers under this warranty must be borne by the purchaser. This warranty does not apply to items which are subject to normal wear or any part or parts which have been subject to misuse, negligence, accident or which have been repaired or altered by other than persons authorized by Winpower.

Winpower shall not be liable for loss, damage or expense directly or indirectly from the use of its product nor for the fitness of product for any specific application or particular purpose.

There is no other express warranty. Winpower hereby disclaims any and all implied warranties, including but not limited to those of merchantability and fitness for a particular purpose to the extent permitted by law.

This warranty is effective only for all PTO driven alternators manufactured after December 15, 1997.

Note: If this alternator is used for standby service, this warranty is void unless a multi-pole, double throw switch is installed between the alternator and the service entrance switch. Do not operate PTO alternator without the shield installed.

WINPOWER

225 South Cordova Avenue
Le Center Minnesota 56057