

TRACTOR DRIVEN ALTERNATOR

20/12 PT2

<u>FIND NO.</u>	<u>PART NO.</u>	<u>DESCRIPTION</u>	<u>REQ'D UNIT</u>
1	G-4776-3	Field Frame Assy	1
2	G-4775-3	Field Frame	1
3	G-4777	Field Pole	4
4	J-528	Coil Shield	8
5	H-984-1	Field Coil	Set Of 4
6	S-859	Lift Ring	1
7	G-2524	Base Assy	1
8	G-4766-30	Armature Assy	1
9	I-861	Fan	1
10	D-3	Bearing - Drive End	1
11	11115	Retaining Ring	1
12	D-8	Bearing - Ring End	1
13	I-686-4	Drive End Bell	1
14	X-177	Gasket	1
15	G-3572-1	Gear Case Housing Assy	1
16	IO-767	Housing	1
17	D-10-1	Bearing Cup	1
18	X-178	Gasket	1
19	IO-770	End Plate	1
20	10800	Vent - Oil Fill	1
21	G-3573-1	Gear Case Cover Assy	1
22	IO-768	Cover	1
23	D-9-1	Bearing Cup	1
24	TE-888	Oil Seal	1
25	S-6289-9	Shim	AR
26	S-1764	Sprocket	1
27	S-6166	Key	1
28	1207	Washer	1
29	11320-2	Screw	1
30	G-4772	Drive Chain	1
31	G-4778	Drive Shaft Assy	1
32	N-457	Shaft	1
33	1210	Woodruff Key	1
34	S-6031	Sprocket	1
35	D-10	Bearing Cone	1
36	D-9	Bearing Cone	1
37	X-180	Gasket	1
38	X-179	Gasket	2
39	TE-901	Oil Seal	1
40	IO-769	Retainer Plate	1
41	G-5487	Brush Gear Assy	1
42	Y-51	Brush	6
43	G-3422	Brush Spring	6
44	4996	Tinnerman	6

PARTS LIST

TRACTOR DRIVEN ALTERNATOR

PL-01025

20/12 PT2

<u>FIND NO.</u>	<u>PART NO.</u>	<u>DESCRIPTION</u>	<u>REQ'D UNIT</u>
45	W-43	Bearing Retainer	1
46	G-5184-1	Panel Front Assy	1
47	G-4771-4	Panel Back Assy (See Separate Drawing)	1
48	S-6927	Top Cover	1
49	G-4770	Guard - PTO	1

Wiring Diagram Z-1680, E-6726
Parts Drawing E-8493

E-8493

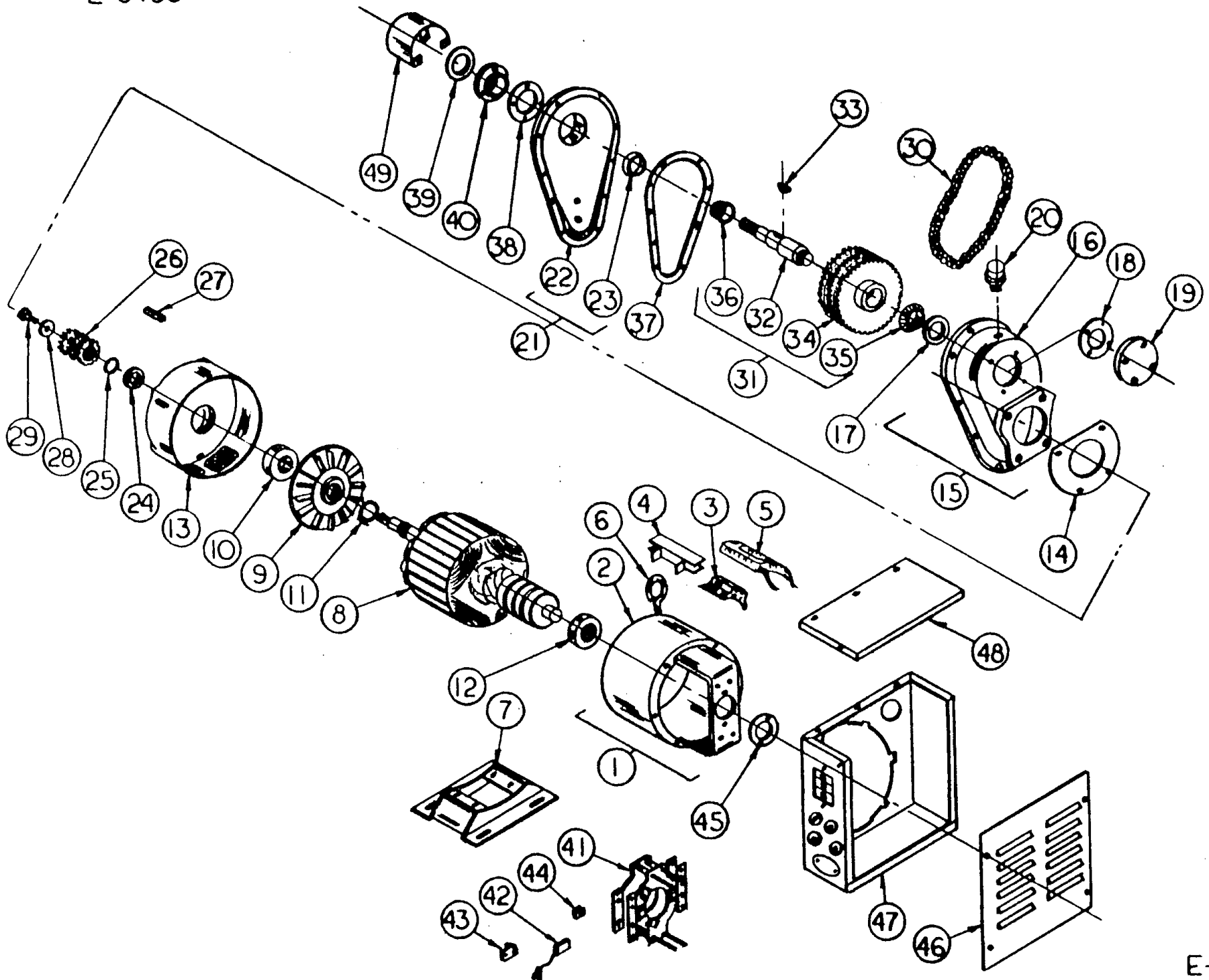

E-8493

E-8545

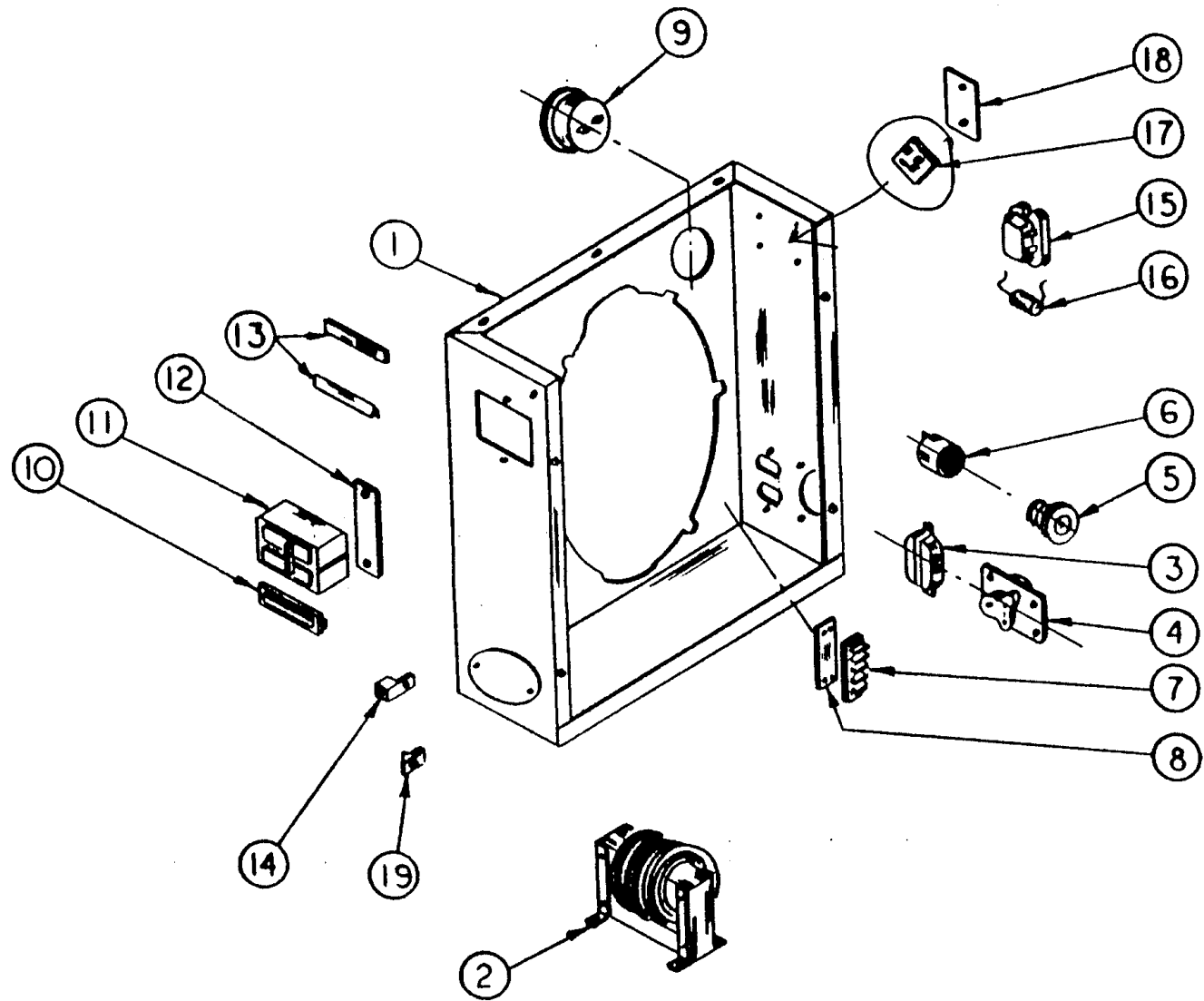

E-8545

PARTS LIST
 PANEL BACK ASSY
 G-4771-4
 (20/12 PT2)

<u>FIND NO.</u>	<u>PART NO.</u>	<u>DESCRIPTION</u>	<u>REQ'D/UNIT</u>
1	G-5838-1	Panel Weld Assy	1
2	EE-1960	Transformer	1
3	EE-323	Receptacle - Duplex	1
4	EE-3031	Receptacle - Load	1
5	EE-447-1	Fuse	1
6	EE-448	Fuse Holder	1
7	EE-654	Terminal Board	1
8	EE-654-2	Insulator	1
9	VM 716	Voltmeter	1
10	EE-779	Filler Plate	1
11	EE28098S	Circuit Breaker	1
12	S-5027-1	Mounting Plate	1
13	W-203	Insulator	2
14	EE-1671	Ground Lug	1
15	EE-2214	Rectifier Assy - Series	1
16	EE-2214	" - Series Fld	1
17	EE-2177	Rectifier Assy - Shunt	1
18	A-786	Heatsink	1
19	4957	Tinnerman	7

Wiring Diagram E-6726
 Parts Drawing E-8545

20/12PT2

SCHEMATIC WIRING

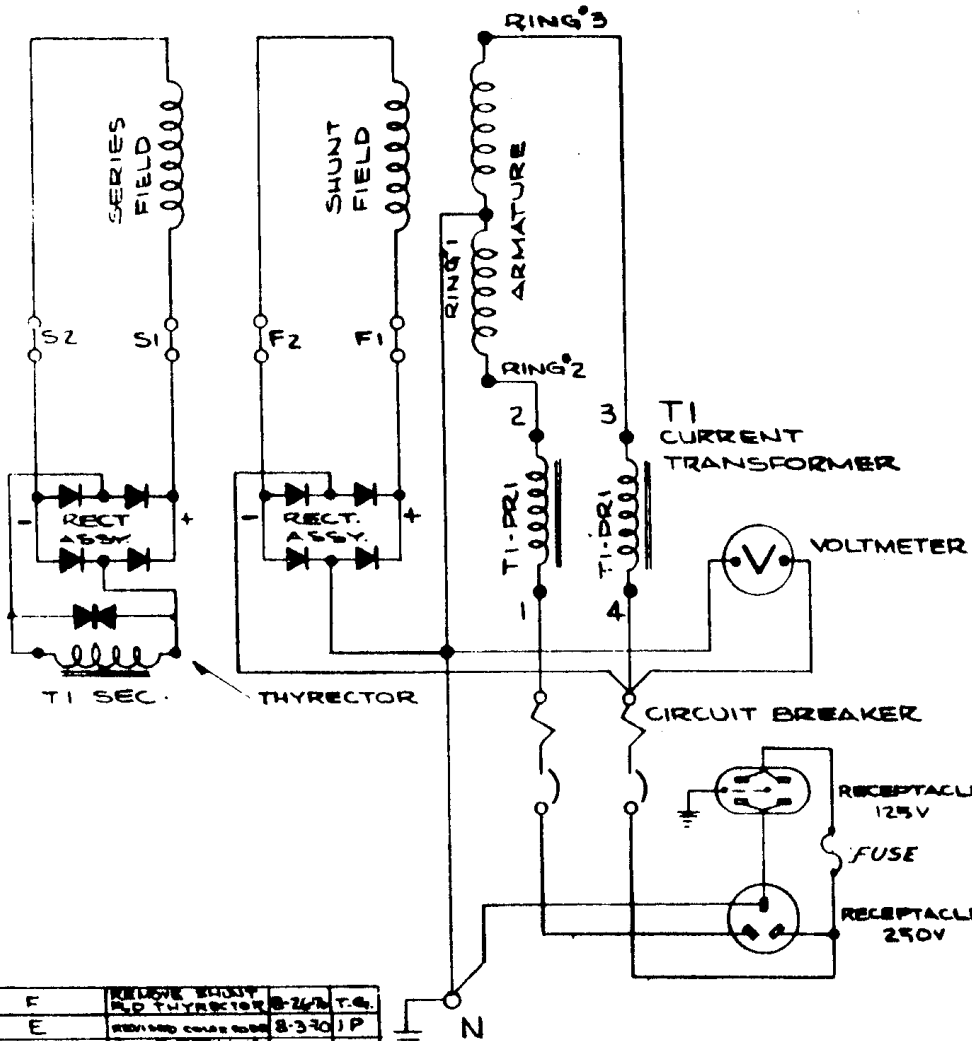

PICTORIAL WIRING

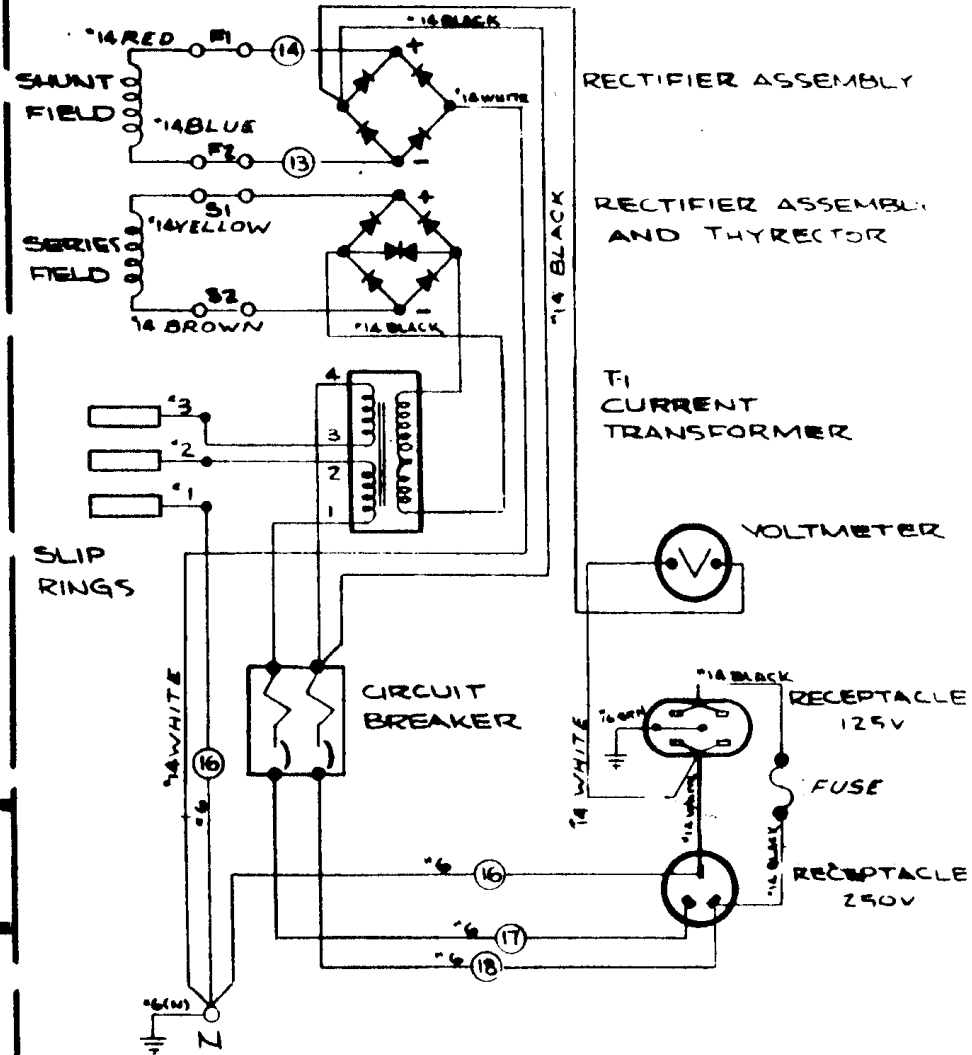

F	REMOVE SHUNT AND THYRECTOR	8-26-67	T.C.G.
E	STANDARD COLOR CODE	8-30-67	J.P.
D	ADD THYRECTOR STRIP	11-12-67	T.C.G.
C	REVISED WIRING	11-30-67	R.L.T.

B	ADDED FUSE	11-2-66	R.L.T.				
A	ADDED NOTE	10-14-66	R.L.T.	C	ADDED COLOR CODE	11-3-67	R.L.T.
CHANGE	WAS ORIGINALLY	DATE	CHK'D				
TOLERANCE ON DIMENSIONS NOT OTHERWISE SPECIFIED				DECIMAL ±	REMOVE ALL BURRS BREAK ALL SHARP MACHINED EDGES	NO. REQ'D.	MICROFILM DATA
				FRACTIONAL ±		JUL 10 1967	
				ANGULAR ±			

WIRING DIAGRAM	
SCALE ~	MODEL NO. 12/20PT2
DATE 9-9-65	PART NO. E-1680
OWN T.C.G.	CHK'D
WINPOWER MFG. CO. NEWTON, IOWA	