

B-300153

REVISION RECORD					
ISSUE	E.C.O. NO.	DESCRIPTION	DATE	BY	APPR.
1	---	ORIGINAL	-----	--	--

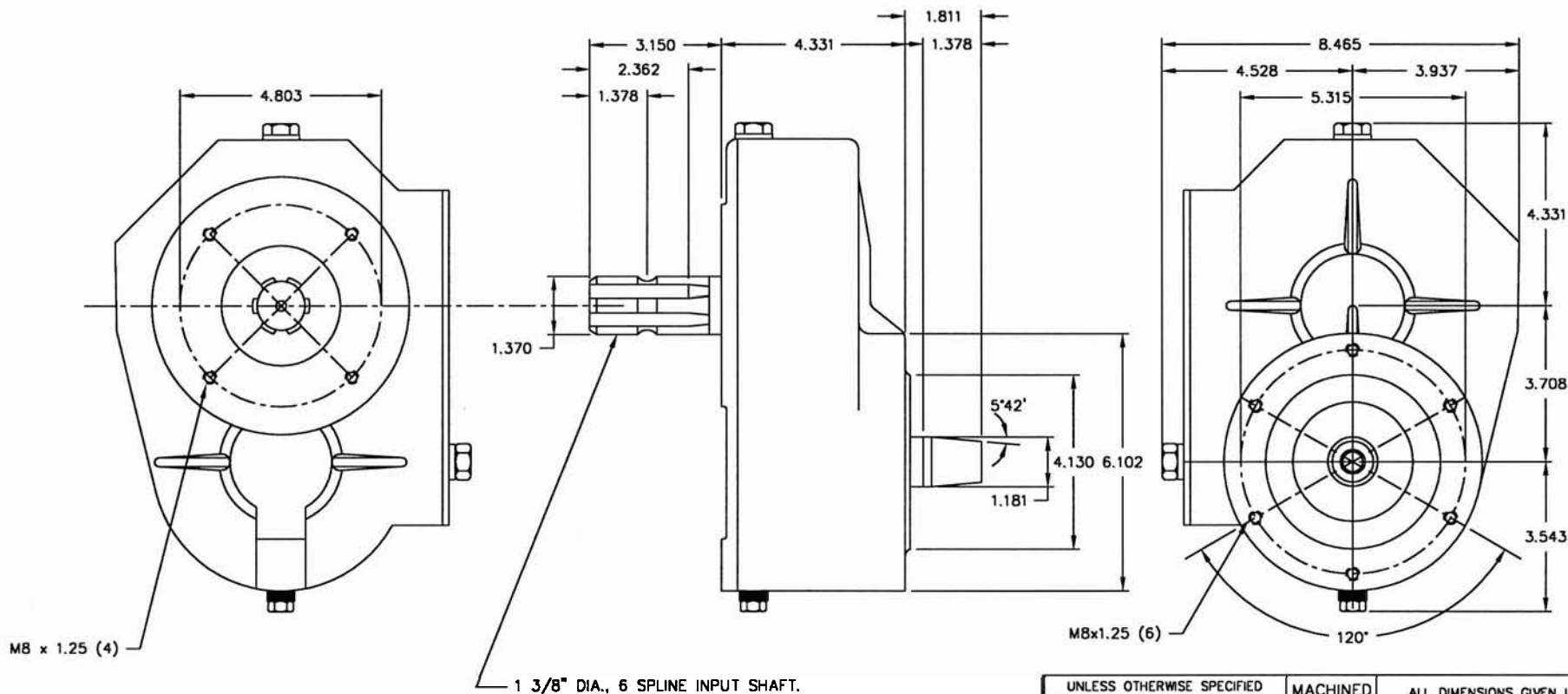

VENDOR: BONDIOLI & PAVESE  
 VENDOR P/N: BIMA M5 GEARCASE  
 BIMA CODE#: 6015.300.070  
 SPEED RATIO: 1:7 (INPUT 540; OUTPUT 3780 RPM)

UNLESS OTHERWISE SPECIFIED		MACHINED SURFACE TEXTURE	ALL DIMENSIONS GIVEN IN INCHES			
FRACTIONS ±	ANGULAR		WORK TO DIMENSIONS			
1. PLACE DEC. ± .1	± 1.5°		- DO NOT SCALE -			
2. PLACE DEC. ± .015						
3. PLACE DEC. ± .005						
THIS DRAWING CONTAINS PROPRIETARY INFORMATION BELONGING TO WINPOWER. UNAUTHORIZED USE IS PROHIBITED.	DRAWN BY DMW	DATE 4-29-98	CHK'D BY	DATE	APP'D BY	SCALE 1=2.5
MATERIAL:		TITLE				
FINISH: RED OXIDE PRIMER		GEAR CASE				
ASS'Y: 14/11PTCD		PART NO. B-300153				
MODEL: SMALL PTO'S		WINPOWER				

# B.I.M.A. GEARBOX REPAIR PROCESS

## M5 GEARBOX, CODE: 6015.300.070

**TOOLS:** 10mm wrench or 10mm socket & ratchet  
Adjustable wrench  
Internal snap ring pliers  
¼" flat tip screwdriver  
Mallet  
Wooden block, 10"x2"x2"  
Flashlight  
Ball Joint Fork Spreader

**PARTS:** Permatex™ Silicone RTV Gasket, available at automotive parts stores or hardware stores.  
BIMA P/N 8050.390.000 if the input shaft or it's anti-friction bearings are removed.  
BIMA P/N 8050.310.000 if the output shaft or it's anti-friction bearings are removed.

### ***TO EXAMINE THE GEARS***

Begin by taking the adjustable wrench and using it to remove either part number 12 or part number 11, the oil drain plug, to allow the oil to drain out of the gearbox housing. If possible, strain or filter the oil as it is pouring out of the gearbox to see if any particles are in the oil. Once the oil has drained out of the housing replace the drain plug back on the gearbox. Replacing the drain plug will make it difficult to misplace the drain plug.

Using the 10mm wrench remove the six M6x16 bolts from the gearbox housing cover, part number 1. Once the 6 bolts have been removed take the mallet and tap the housing cover to break the seal between the housing cover and the gearbox housing, part number 5. DO NOT pry the housing cover off with a screwdriver. Prying the housing cover off with a screwdriver may damage the housing cover's contact surface.

Once the housing cover has been removed, use the flashlight to examine the gears. If the gearbox has had at least fifty hours of operation, then the gear teeth should have a smooth appearance. The indications of damaged gears are as follows.

- 1) Broken gear teeth
- 2) Chipped gear teeth
- 3) Cracked gear teeth
- 4) Pitted gear teeth

Try to turn one of the shafts by hand to examine all of the gear teeth. If any of the gear teeth have one of the 4 problems mentioned above then it is recommended that both of the gears should be replaced. See that attached exploded drawing for the part numbers for the gears.

To remove the gears begin by follow the process "*TO EXAMINE THE BEARINGS.*"

### ***TO EXAMINE THE BEARINGS***

Begin by using the screwdriver to remove part number 7 and part number 16, the shaft seals. It is almost impossible to remove the shaft seals from the gearbox housing without destroying the shaft seals. This is why the shaft seals are listed as a required part to replace.

Now that the shaft seals have been removed, begin examining the anti-friction bearings. Check the bearings for discoloration or if the ball bearings are intact inside the ball bearing cage. You will also want to see if the shaft has any lateral play. Those are the first 3 immediate signs that the gearbox may have bad anti-friction bearings.

Next using the snap ring pliers, remove the snap rings, part number 6, that hold the anti-friction bearings in place. Once the snap rings have been removed the shafts and bearings can be removed by placing the ball joint fork spreader inside the gearbox to separate part number 4, the output shaft, and part number 17, an anti-friction bearing. Use the mallet to TAP the fork spreader in between the shaft and the bearing. This should slowly force the shaft and one of the bearings out of the gearbox without damaging part number 17 or the output shaft. Remember that the output shaft, part number 4, is also a gear so unless the gear is already damaged you do not want to damage any of the gear teeth. Check the anti-friction bearing, part number 17, for discoloration. Make sure that the ball bearings are intact inside their cage and check the inner and outer races for pitting and scoring. If the bearing shows any of the above mentioned signs of wear or break down it is recommended to replace the anti-friction bearing. The code for the anti-friction bearings can be found on the attached exploded drawing. For part number 9 & part number 17 you may have to break the ball bearing cage and remove the anti-friction bearings in pieces. But if the part number 9 or part number 17 do not show signs of wear or break down it is not recommended that they should be removed from the gearbox housing.

The same process is used for removing the input shaft, part number 2, as used for removing the output shaft. As a rule of thumb, you will want to remove the output shaft first to make removing the input shaft easier. You will want to make sure you do not damage the large gear, if it has not already been damaged.

#### ***REPLACING BEARINGS***

When replacing bearings use the wooden block and mallet to tap the anti-friction bearing into place. Do not drive one side of the bearing down into the housing and then the other side of the bearing this will damage the bearing and the gearbox housing. Try to tap the bearing slowly and evenly into position.

You may want to use 10"x2"x2" block of wood when replacing part number 9 & part number 17. This would give the bearing and the housing the cushion they need and the extension you will need.

#### ***REPLACING THE SHAFTS AND GEARS***

Place the gearbox on its side such that the hole that the input shaft will protrude from is face up. Place the large gear, part number 3, on top of part number 9. Insert the input shaft into the gearbox and have the 8 splines engage the large gear. After the input shaft is partly engaged with large gear, begin to align the shaft with part number 9. Once the input shaft is center into the bearing, part number 9, begin tapping the shaft into place with the mallet until the shaft has bottomed out. When the input shaft has bottomed out, place part number 10 over the input shaft and allow the bearing to slide down the shaft. The bearing should come to rest near the housing without being forced. Using the input shaft as a guide, take the block of wood and place it against the shaft. Begin tapping the bearing into the housing. Tap the bearing deep enough into the gearbox housing so that it clears the snap ring groove. Replace the snap ring, part number 6, into the housing and make sure that it is seated properly into the housing. Do not replace the shaft seal yet.

Turn the gearbox over. Install the output shaft by centering it with the bearing, part number 17, and engage the gear section of the shaft with the large gear. Tap the shaft with the mallet until the shaft bottoms out against the bearing. Place the anti-friction bearing, part number 8, on the output shaft and allow it to settle as far down the shaft as the output shaft will allow. Placing the block of wood against the shaft and on top of the bearing, begin tapping the block of wood with the mallet. You must tap the bearing deep enough into the housing until the bearing clears past the snap ring groove. Replace the snap ring, part number 6, and be certain that the snap ring is properly seated in the snap ring groove. Do not replace the shaft seal for the output shaft yet.

#### ***REPLACING THE SHAFT SEALS***

Turn the input shaft and the output shaft by hand both clockwise and counter clockwise. Make certain that the shafts turn easily. If the shafts turn easily then the gearbox has been properly reassembled and all that remains is to install the shaft seal, tighten the drain plugs, install the gearbox, and refill the gearbox SAE 90 gearbox oil.

Place the gearbox so that the input shaft, the 1-3/8" 6-spline shaft, is pointing up. Place part number 7, a shaft seal, over the input shaft and slide the seal down the shaft until the seal is resting on the gearbox

housing. Be careful not to damage the seal lips on the splines of the shaft. Using the block of wood as a punch, carefully tap around the seal until the seal is flush with the machined surface of the gearbox housing around the input shaft. The seal can set 1/32" below the machined surface of the gearbox housing. The seal lip should not have fold back. The seal should set evenly around the shaft and the housing so that it does not leak oil.

Once the input shaft seal has been properly installed, the gearbox should be turned over to allow the installation of the output shaft seal. Place part number 16, the output shaft seal over the output shaft. Do not allow the seal lips to fold back as you slide the seal down the output shaft. Place the seal so that it rests against the housing. Put the block of wood on top of the seal and against the output shaft. Using the block of wood as a punch, tap around the seal until the seal is flush with the machined surface of the gearbox housing. The seal can set 1/32" below the machine surface. Remember do not bend or deform the seal around the housing or the output shaft. The seal should not leak oil.

#### ***REPLACING THE HOUSING COVER***

Remove the residual sealant from the housing and the housing cover. Make certain that none of the sealant in the bolt holes will interfere with creating a proper seal around the housing cover. Remember you want to avoid conditions that would create an oil leak. Once the residual sealant has been removed a new layer of sealant can be applied. Using the Permatex™ silicone RTV gasket place a continuous bead around the outer part of the machined surface that the housing cover will bolt to. Insert the M6 bolts and hand tighten the bolts. Then take the wrench and tighten the bolts. Be careful not to over tighten the bolts with the wrench because you do not want to strip the bolt holes in the housing or break the bolts. It is not a problem if the some of the sealant is purged out of the edges of the housing cover.

#### ***FINIAL INSTALLTION***

Check the drain plugs and make certain they will not leak. Install the gearbox on the machine and fill the gearbox with 0.75kg of SAE 90 gear oil or fill with SAE 90 oil to the sight glass.

BIMA SRL

+039522513295

13/01 '99 09:41 NO.500 02/02



LIST OF SPARE PARTS  
PIECES DE RECHANGE  
ERSATZTEILE

GRUPE GETREBE  
M 5

CODE BESTELLNUMMER  
6015.300.070  
EX 95047

REF. CLIENT BEZUG KUNDE

DATE DATUM  
17.02.95

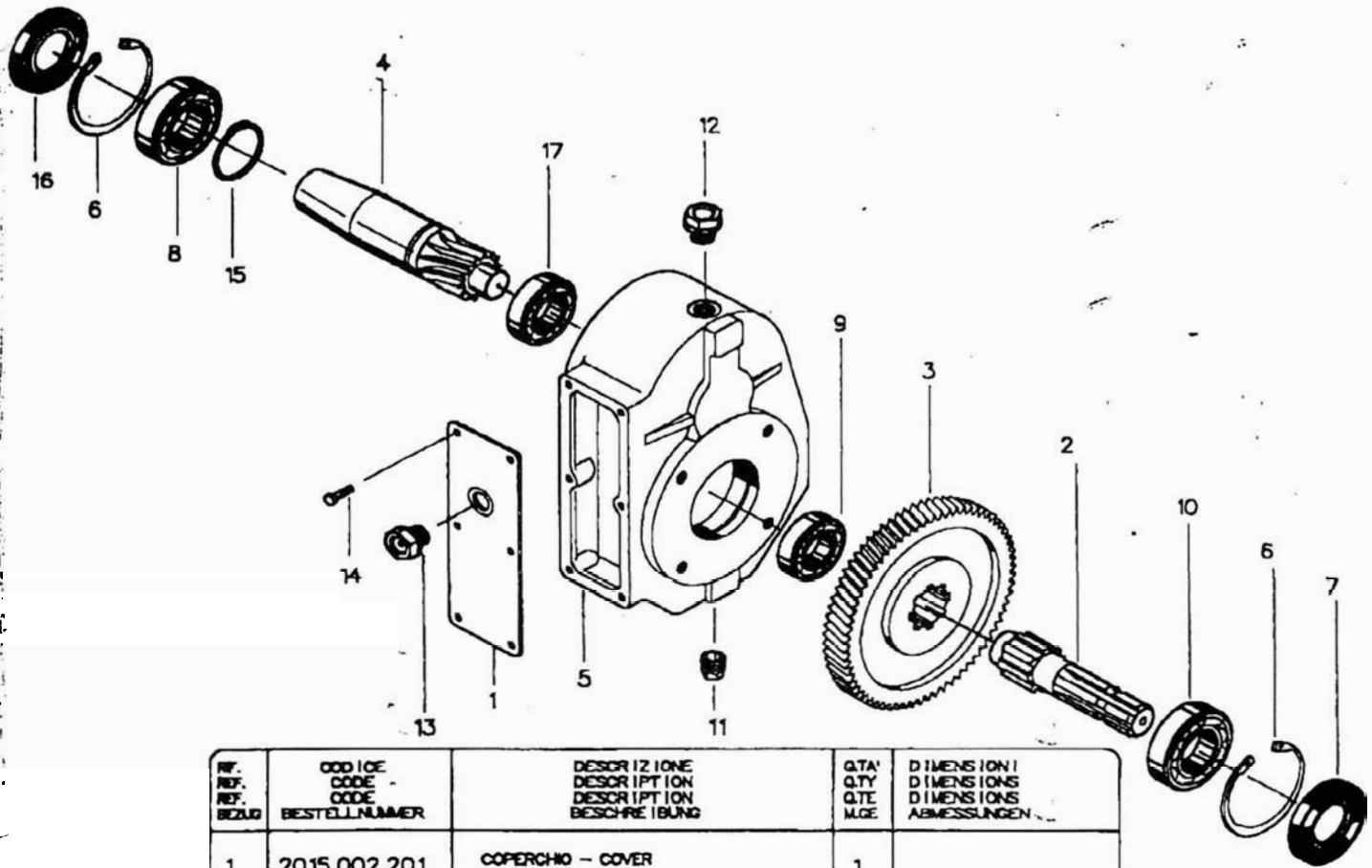

REF. REF. BEZUG	CODE CODE - CODE BESTELLNUMMER	DESCRIZIONE DESCR IPTION DESCR IPTION BESCHRE IBUNG	QTA' QTY Q.TE M.CE	DIMENSIONI DIMENSIONS DIMENSIONS ABMESSUNGEN
1	2015.002.201	COPERCHIO - COVER COUVERCLE - DECKEL	1	
2	2015.005.542	ALBERO - SHAFT ARBRE - WELLE	1	
3	2015.011.426	INGRANAGGIO - GEAR ENGRENAGE - ZAHNRAD	1	
4	2015.047.542	ALBERO - SHAFT ARBRE - WELLE	1	
5	2015.001.101	SCATOLA - HOUSING CARTER - GEMAUSE	1	
6	8025.545.000	SEDEER - CIRCLIP CIRCLIP - SICHERUNGSRING	2	D 72 I
7	8050.390.000	ANELLO TENUTA - OIL SEAL BAGUE D'ETANCHEITE' - SIMMERRING	1	35x72x10
8	8200.220.000	CUSCINETTO - BEARING ROULEMENT - LAGER	1	6306
9	8200.216.000	CUSCINETTO - BEARING ROULEMENT - LAGER	1	6206
10	8200.240.000	CUSCINETTO - BEARING ROULEMENT - LAGER	1	6207
11	8600.136.000	TAPPO OLIO - OIL FLUG BOUCHON - OELINFUELLSCHRAUBE	1	3/8" GAS
12	8600.144.000	TAPPO OLIO - OIL FLUG BOUCHON - OELINFUELLSCHRAUBE	1	3/8" GAS
13	8625.136.000	TAPPO OLIO - OIL FLUG BOUCHON - OELINFUELLSCHRAUBE	1	3/8" GAS
14	8675.065.100	VITE - SCREW BOULON - SCHRAUBE	6	M6x16 UNI5739
15	8025.302.000		1	D 30 E
16	8050.310.000	ANELLO TENUTA - OIL SEAL BAGUE D'ETANCHEITE' - SIMMERRING	1	30x72x10
17	8200.196.001		1	6305 SKF

BIMA si riserva di apportare modifiche senza preavviso BIMA reserve the right to change specifications without notice  
BIMA se réserve le droit de modifier ses modèles sans aucun préavis BIMA behält sich technische Änderungen vor ohne Mitteilung BIMA ©COPYRIGHT 7/89

BIMA Via F. Casorati n.7 Reggio E. 42100 ITALY Tel. (0522) 511300 Telefax (0522) 513295